

**GUARANTEED
LOWEST
PRICES**

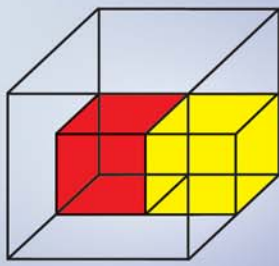

**QUANTUM[®]
STORAGE
SYSTEMS**



**THE LARGEST SELECTION OF PLASTIC BINS,
STEEL & WIRE SHELVING AND COMPLETE BIN SYSTEMS**

TABLE OF CONTENTS

















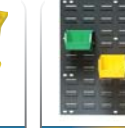



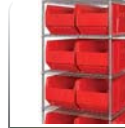









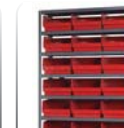





































 PAGE 4-5 NEW! CLEAR-VIEW ULTRA BINS & PACKAGES	 PAGE 6 NEW! CLEAR-VIEW 24" CONTAINERS & PACKAGES	 PAGE 7-8 NEW! CLEAR-VIEW SHELF BINS & PACKAGES	 PAGE 9 NEW! CLEAR-VIEW GIANT STACK CONTAINERS	 PAGE 10 NEW! CLEAR-VIEW SHELF BINS & PACKAGES	 PAGE 11 BIN, TOTE & CONTAINER LABELS	 PAGE 12-13 ULTRA STACK AND HANG BINS	 PAGE 14-15 LOUVERED PANELS & BENCH RACKS	 PAGE 16-18 RACKS & RAIL SYSTEMS
 PAGE 19 NEW! 1900 SERIES STACKING SHELF BINS	 PAGE 20-21 GIANT OPEN HOPPER BIN SYSTEMS	 PAGE 22-24 HULK 24" CONTAINERS	 PAGE 25-27 HULK 30" & 36" CONTAINERS	 PAGE 28-29 NEW! RACKBIN 42" CONTAINERS	 PAGE 30-32 GIANT STACK CONTAINERS	 PAGE 33-35 GIANT OPEN HOPPER MAGNUM BINS	 PAGE 36-40 HEAVY-DUTY CABINETS & RAIL CARTS	 PAGE 41 ECONOMY SHELF BINS
 PAGE 42 SHELF BIN STEEL SHELVING SYSTEMS	 PAGE 43 SLOPED PICK RACKS	 PAGE 44-45 SHELF BIN & HIGH DENSITY WIRE SHELVING SYSTEMS	 PAGE 46 STORE-MORE 6" SHELF BINS	 PAGE 47-48 STORE-MORE SHELF BIN SHELVING SYSTEMS	 PAGE 49 SUPER TUFF EURO DRAWERS	 PAGE 50 EURO DRAWERS SHELVING SYSTEMS	 PAGE 51 EURO DRAWERS SLOPED SHELVING SYSTEMS	 PAGE 52 QUICKPICK BINS & WIRE SHELVING SYSTEMS
 PAGE 53 HIGH PERFORMANCE STACK AND LOCK BINS	 PAGE 54 RECYCLED BINS	 PAGE 55 CONDUCTIVE ESD BINS, HANGING SYSTEMS & RACKS	 PAGE 56 CONDUCTIVE ESD HANGING SYSTEMS & RACKS	 PAGE 57 CONDUCTIVE ESD SHELF BINS & DIVIDABLE CONTAINERS	 PAGE 58-59 CLEAR TIP OUT BIN SYSTEMS	 PAGE 60 CLEAR TIP OUT BIN RAILS & FRAMES	 PAGE 61 FREE STANDING & GONDOLA SLIDER SYSTEMS	 PAGE 62-63 SINGLE & DOUBLE SIDED CLEAR TIP OUT BIN STANDS
 PAGE 64-65 INTERLOCKING STORAGE CABINETS & STANDS	 PAGE 66 TOOL STORAGE & ORGANIZERS	 PAGE 67 DOLLIES, COLLAPSABLE & STACKER CONTAINERS	 PAGE 68-69 GENUINE STACK AND NEST TOTES	 PAGE 70 DIVIDABLE GRID CONTAINERS	 PAGE 71 CROSS STACK TUBS & QUANTUBS	 PAGE 72 WIRE SHELVING SYSTEMS	 PAGE 73 ATTACHED TOP CONTAINERS	 PAGE 74 NEW! COLLAPSABLE BULK BOX
 PAGE 75 PLASTIC MOBILE CARTS	 PAGE 76-77 NEW! TRANSPORT & TRAY TRUCKS	 PAGE 78-85 IRONMAN 18 & 20 GAUGE STEEL SHELVING SYSTEMS	 PAGE 86 IRONMAN 22 GAUGE STEEL SHELVING SYSTEMS	 PAGE 87-89 WIRE SHELVING SYSTEM	 PAGE 90-93 WIRE SHELVING STARTER & ADD-ON KITS	 PAGE 94 PROFORM WIRE SHELVING SYSTEM	 PAGE 95 STAINLESS STEEL WIRE SHELVING SYSTEM	 PAGE 96 SOLID SHELF STARTER & ADD-ON KITS
 PAGE 97 SLANTED SHELF WIRE SHELVING SYSTEMS	 PAGE 98 SHELVES, FRAMES & BASKETS	 PAGE 99 DUNNAGE & PLATFORM RACKS	 PAGE 100-101 WIRE STACKING BASKETS	 PAGE 102-103 NEW! PARTITION WALL SYSTEMS	 PAGE 104-105 NEW! Q-PEG WALL SYSTEM	 PAGE 106-107 CANTILEVER WALL MOUNT SYSTEMS	 PAGE 108 NEW! GRID-STORE WALL MOUNTED SYSTEMS	 PAGE 109-112 STEM CASTER, ENCLOSURE & LINEN CARTS
 PAGE 113-114 SECURITY CARTS & COVERS	 PAGE 115 WIRE UTILITY CARTS	 PAGE 116 MODULAR TRAYS & TRAY CARTS	 PAGE 117 BIN CARTS	 PAGE 118-121 HEALTHCARE & MEDICAL	 PAGE 122 STAINLESS STEEL	 PAGE 123-125 CASTERS & WIRE SHELVING ACCESSORIES	 PAGE 126-127 HIGH DENSITY SLIDING TRACK SYSTEM	 PAGE 128 LAYOUT & DESIGN SERVICES

TABLE OF CONTENTS

Pg. 4 NEW! Clear-View Ultra Bins and Packages	Pg. 68 GENUINE stack and nest totes
Pg. 5 NEW! Clear-View Ultra Bins and Packages	Pg. 69 GENUINE stack and nest totes
Pg. 6 NEW! Clear-View 24" Containers and Packages	Pg. 70 Dividable Grid Containers
Pg. 7 NEW! Clear-View Shelf Bins and Packages	Pg. 71 Cross Stack Tubs & QuanTubs
Pg. 8 NEW! Clear-View Shelf Bins and Packages	Pg. 72 Wire Shelving Systems
Pg. 9 NEW! Clear-View Giant Stack Containers	Pg. 73 Attached Top Containers
Pg. 10 NEW! Clear-View Dividable Grid Containers	Pg. 74 NEW! Collapsible Bulk Box
Pg. 11 Bin, Tote and Container Labels	Pg. 75 Plastic Mobile Carts
Pg. 12 Ultra Stack and Hang Bins	Pg. 76 NEW! Bin Transport & Sloped Shelf Trucks
Pg. 13 Ultra Stack and Hang Bins	Pg. 77 NEW! Removable Tray Trucks
Pg. 14 Louvered Panels	Pg. 78 IRONMAN 18 & 20 Gauge Steel Open Shelving
Pg. 15 Louvered Panels & Bench Racks	Pg. 79 Open Steel Shelving - Starter Units
Pg. 16 Louvered Racks	Pg. 80 IRONMAN 18 & 20 Gauge Steel Open Shelving
Pg. 17 Hanging Rail Systems	Pg. 81 Open Steel Shelving - Add-On Units
Pg. 18 Complete Package Units	Pg. 82 IRONMAN 18 & 20 Gauge Closed Steel Shelving
Pg. 19 NEW! 1900 Series	Pg. 83 Closed Steel Shelving - Starter Units
Pg. 20 GIANT Open Hopper Storage Units	Pg. 84 IRONMAN 18 & 20 Gauge Closed Steel Shelving
Pg. 21 GIANT Open Hopper Wire Shelving Systems	Pg. 85 Closed Steel Shelving - Add-On Unit
Pg. 22 HULK 24" Containers	Pg. 86 IRONMAN 22 Gauge Steel Shelving
Pg. 23 HULK Shelving Systems - Complete Packages	Pg. 87 Wire Shelving System Finishes
Pg. 24 HULK Shelving Systems - Complete Packages	Pg. 88 Wire Shelves
Pg. 25 HULK 30" & 36" Containers	Pg. 89 Wire Shelving Posts / Solid Shelves
Pg. 26 HULK 30" Wire - Complete Packages	Pg. 90 54" Chrome Wire Shelving Systems
Pg. 27 HULK 36" Wire - Complete Packages	Pg. 91 63" Chrome Wire Shelving Systems
Pg. 28 NEW! Rack Bin Containers	Pg. 92 74" Chrome Wire Shelving Systems
Pg. 29 NEW! Rack Bin Containers Wire Packages	Pg. 93 86" Chrome Wire Shelving Systems
Pg. 30 GIANT Stack Containers	Pg. 94 Proform Wire Shelving Units
Pg. 31 GIANT Stack Container Storage Center	Pg. 95 Stainless Steel Wire Shelving Units
Pg. 32 GIANT Stack Container Wire Storage Center	Pg. 96 Solid Shelf Units
Pg. 33 GIANT Open Hopper Magnum Bins	Pg. 97 Slanted Shelf Wire Shelving Units
Pg. 34 MAGNUM Bin Units Complete Package	Pg. 98 Shelves, Frames & Baskets
Pg. 35 MAGNUM Bin Wire Units Complete Packages	Pg. 99 Dunnage & Platform Racks
Pg. 36 Heavy-duty 36" Wide All-Welded Bin Cabinets	Pg. 100 Wire Stacking Baskets
Pg. 37 Heavy-duty 36" & 48" Specialty Bin Cabinets	Pg. 101 Wire Basket Units
Pg. 38 Heavy-duty 48" Wide All-Welded Bin Cabinets	Pg. 102 NEW! PARTition Level Wall Systems
Pg. 39 Economy Cabinets/Rail Carts	Pg. 103 NEW! PARTition Hanging Baskets & Systems
Pg. 40 Heavy-duty 60" & 72" Bin Cabinets	Pg. 104 NEW! Q-Peg Wall Systems
Pg. 41 Economy Shelf Bins	Pg. 105 NEW! Q-Peg Wall System Accessories
Pg. 42 Shelf Bin Shelving Systems	Pg. 106 Cantilever Wall Mount Systems
Pg. 43 Economy Shelf Bins Sloped Shelving Units	Pg. 107 Cantilever Wall Mount - Complete Packages
Pg. 44 Shelf Bin Wire Shelving Systems	Pg. 108 NEW! Grid-Store Wall Mounted Systems
Pg. 45 High Density Wire Systems	Pg. 109 Stem Caster Carts
Pg. 46 Store-More 6" Shelf Bins	Pg. 110 Enclosure Carts
Pg. 47 Store-More Shelf Bin Shelving Systems	Pg. 111 Enclosure Carts
Pg. 48 Store-More Shelf Bin Shelving Systems	Pg. 112 Linen & Bin Transport Carts
Pg. 49 Super Tuff Euro Drawers	Pg. 113 Security Units
Pg. 50 Euro Drawers Shelving Systems	Pg. 114 Wire Carts Covers
Pg. 51 Euro Drawers Sloped Shelving Systems	Pg. 115 Wire Utility Carts
Pg. 52 QUICKPICK Bins and Wire Shelving Systems	Pg. 116 Modular Trays & Tray Carts
Pg. 53 High Performance Stack and Lock Bins	Pg. 117 Bin Carts
Pg. 54 Recycled Bins	Pg. 118 Healthcare & Medical
Pg. 55 Conductive Bins, Hanging Systems & Racks	Pg. 119 Healthcare & Medical
Pg. 56 Conductive Hanging Systems & Racks	Pg. 120 Healthcare & Medical
Pg. 57 Conductive Shelf Bins & Dividable Containers	Pg. 121 Healthcare & Medical
Pg. 58 Clear Tip Out Bin Systems	Pg. 122 Stainless Steel
Pg. 59 Clear Tip Out Bin Systems	Pg. 123 Wire Shelving Accessories
Pg. 60 Clear Tip Out Bin Rails & Frames	Pg. 124 Wire Shelving Accessories
Pg. 61 Free Standing & Gondola Slider Systems	Pg. 125 Wire Shelving Accessories
Pg. 62 Single & Double Sided Tip Out Bin Stands	Pg. 126 High Density Sliding Track System
Pg. 63 Mobile Clear Tip Out Bin Stands	Pg. 127 High Density Sliding Track System
Pg. 64 Interlocking Storage Cabinets	Pg. 128 Layout & Design Services
Pg. 65 Interlocking Storage Cabinet Floor Stands	Pg. 129 Quick Find Model Number Index
Pg. 66 Tool Storage & Organizers	Pg. 130 Quick Find Model Number Index
Pg. 67 Dollies, Collapsible & Stacker Containers	Pg. 131 Quick Find Model Number Index

new PRODUCTS

Clear-View

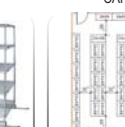

Available on Pages 4-10

1900 Series



Available on Page 19

Rack Bin

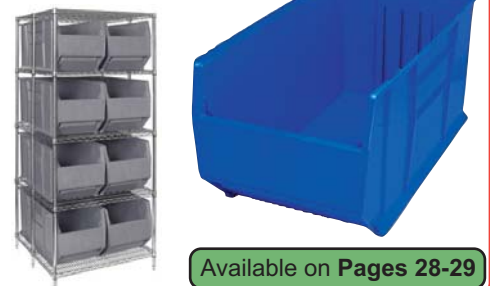

Available on Pages 28-29

PARTition



Available on Pages 102-103

Q-Peg

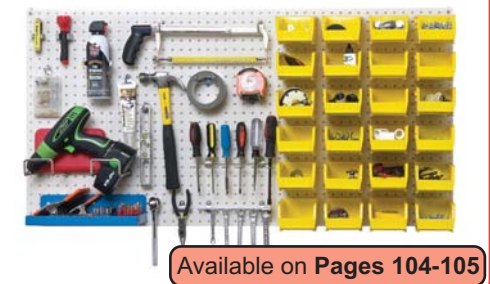

Available on Pages 104-105

The largest selection of plastic bins, steel & wire shelving and storage containers.

NEW! CLEAR-VIEW ULTRA BINS AND PACKAGES

Clear-View Ultra Hang-and-Stack Bins

Organize your inventory with strong injection molded tri-clear polypropylene bins. Front, back and side grips for easy handling. Built in rear hanger allows bins to hang from louvered panels or rails. Optional clear injection molded crystal styrene window increases bin capacity and provides quick view of bin contents. Dividers maximize flexibility and keep contents organized. Wide stacking ledge and anti-slide lock keep stacked bins steady and prevent forward shifting. Waterproof bins resist rust and corrosion. Large molded front label slots for ID labels. Autoclavable up to 250°F and resistant to extreme cold. Color: Clear.



Shown with optional window & dividers, available on page 13

MODEL NO.	OUTSIDE DIMENSIONS L" x W" x H"	CTN QTY	CTN WGT
QUS200CL	5" x 4-1/8" x 3"	24	5 lbs
QUS210CL	5-3/8" x 4-1/8" x 3"	24	6 lbs
QUS220CL	7-3/8" x 4-1/8" x 3"	24	8 lbs
QUS221CL	9-1/4" x 6" x 5"	12	6 lbs
QUS224CL	10-7/8" x 4-1/8" x 4"	12	8 lbs
QUS230CL	10-7/8" x 5-1/2" x 5"	12	10 lbs
QUS233CL	13-1/2" x 5-1/2" x 5"	12	13 lbs
QUS234CL	14-3/4" x 5-1/2" x 5"	12	14 lbs
QUS235CL	10-7/8" x 11" x 5"	6	10 lbs
QUS239CL	10-3/4" x 8-1/4" x 7"	6	10 lbs
QUS240CL	14-3/4" x 8-1/4" x 7"	12	24 lbs
QUS241CL	13-5/8" x 8-1/4" x 6"	12	22 lbs
QUS242CL	13-5/8" x 8-1/4" x 8"	12	25 lbs
QUS245CL	10-7/8" x 16-1/2" x 5"	6	13 lbs
QUS250CL	14-3/4" x 16-1/2" x 7"	6	21 lbs
QUS255CL	16" x 11" x 8"	4	14 lbs
QUS260CL	18" x 11" x 10"	4	17 lbs
QUS265CL	18" x 8-1/4" x 9"	6	17 lbs
QUS270CL	18" x 16-1/2" x 11"	3	16 lbs
QUS275MOBCL	18" x 16-1/2" x 11"	3	25 lbs

* With casters, overall height for mobile container will be increased by 3"
Individual labels are available for all Ultra Bins. Ctn Qty: 50 Individual Labels
For label Model No., substitute "L" for "Q" in bin Model No.

QUANTUM IS CLEARLY your Storage Solution!

Clear-View Hang-and-Stack Bins - Complete Wire Packages

Manufactured of FDA approved, heavy-duty tri-clear polypropylene allowing quick identification of the contents of any bin.

MODEL NO.	NO. OF SHELVES	NO. OF BINS	BIN SIZE L" x W" x H"	SHIP WGT
12" x 36" x 74" Unit				
WR8-239CL	8	28 QUS239CL	10-3/4" x 8-1/4" x 7"	103 lbs
WR7-245CL	7	24 QUS245CL	10-7/8" x 16-1/2" x 5"	111 lbs
14" x 36" x 74" Unit				
WR10-230240CL	10	36 QUS230CL 12 QUS240CL	10-7/8" x 5-1/2" x 5" 14-3/4" x 8-1/4" x 7"	146 lbs
WR8-240CL	8	28 QUS240CL	14-3/4" x 8-1/4" x 7"	128 lbs
WR8-250CL	8	14 QUS250CL	14-3/4" x 16-1/2" x 7"	129 lbs
WR8-255CL	8	21 QUS255CL	16" x 11" x 8"	152 lbs
18" x 36" x 74" Unit				
WR6-260CL	6	15 QUS260CL	18" x 11" x 10"	127 lbs
WR6-265CL	6	20 QUS265CL	18" x 8-1/4" x 9"	124 lbs
WR5-270CL	5	8 QUS270CL	18" x 16-1/2" x 11"	104 lbs



WR8-239CL
12"W x 36"L x 74"H
8 shelves and 28 QUS239
10-3/4"L x 8-1/4"W x 7"H bins



MOBILIZE YOUR WIRE SHELVING



DB - Donut Bumper

Non-marking donut bumper used to protect walls and help cushion impact.

WR-00H (Mobile Kit)*

Set of four swivel polyurethane 5" x 1-1/4" casters, two with brakes. Can be used with all units shown. 1,200 lb. load capacity. *Mobile kits recommended only for shelves 18" and wider

NEW! CLEAR-VIEW ULTRA BINS AND PACKAGES

Clear-View Bench Racks & Louvered Panel

Bench Racks: 36"L x 8"W x 19"H and 27"L x 8"W x 21"H. Both bench racks are available in 3 preconfigured choices. Bench racks can be joined together to form continuous systems.

Louvered Panels: 36"L x 19"H and 18"L x 19"H. Each available in 3 configurations. Louvered Panels are available in Gray or Beige color. To order a Beige Louvered Panel add BG to the model number (i.e. QLP-1819BG-210-18CL). Bins are available in Clear.

MODEL NO.	NO. OF BINS	BIN DIMENSIONS L" x W" x H"	SHIP WGT
Bench Rack 27"L x 8"W x 21"H With Bins			
QBR-2721-210-24CL	24	5-3/8" x 4-1/8" x 3"	23 lbs
QBR-2721-220-24CL	24	7-3/8" x 4-1/8" x 3"	25 lbs
QBR-2721-230-12CL	12	10-7/8" x 5-1/2" x 5"	28 lbs
Bench Rack 36"L x 8"W x 19"H With Bins			
QBR-3619-210-32CL	32	5-3/8" x 4-1/8" x 3"	29 lbs
QBR-3619-220-32CL	32	7-3/8" x 4-1/8" x 3"	31 lbs
QBR-3619-230-18CL	18	10-7/8" x 5-1/2" x 5"	37 lbs
Louvered Panel 18"L x 19"H With Bins			
QLP-1819-210-16CL	16	5-3/8" x 4-1/8" x 3"	11 lbs
QLP-1819-220-16CL	16	7-3/8" x 4-1/8" x 3"	12 lbs
QLP-1819-230-9CL	9	10-7/8" x 5-1/2" x 5"	16 lbs
Louvered Panel 36"L x 19"H With Bins			
QLP-3619-210-32CL	32	5-3/8" x 4-1/8" x 3"	22 lbs
QLP-3619-220-32CL	32	7-3/8" x 4-1/8" x 3"	24 lbs
QLP-3619-230-18CL	18	10-7/8" x 5-1/2" x 5"	30 lbs



QBR-2721-220-24CL



QLP-1819-230-9CL



HNS230CL

Clear-View Hang-and-Stack Bins

- Complete Packages

Comes with 2 handy 12" plastic rails ideal for mounting to any surface. Bins can hang or stack securely providing an efficient bin storage system. Available in Clear. Rails available in White.

MODEL NO.	BIN DIMENSIONS L" x W" x H"	DESCRIPTION	SHIP WGT
HNS200CL	5" x 4-1/8" x 3"	6 bins + 2 rails	2 lbs
HNS210CL	5-3/8" x 4-1/8" x 3"	6 bins + 2 rails	2 lbs
HNS220CL	7-3/8" x 4-1/8" x 3"	6 bins + 2 rails	3 lbs
HNS230CL	10-7/8" x 5-1/2" x 5"	4 bins + 2 rails	5 lbs
HNS006	Extra Rails	2 rails	1 lb



QRU-12D-220-192CL + QRU-MOB
Double Sided Rack, 12 Rails
with Mobile Kit
500 lb. capacity.

MODEL NO.	NO. OF BINS	BIN DIMENSION L" x W" x H"	SHIP WGT
Single Sided Rail System 36"L x 15"W x 53"H With Bins			
QRU-12S-220-96CL	96	7-3/8" x 4-1/8" x 3"	82 lbs
QRU-16S-230-48CL	48	10-7/8" x 5-1/2" x 5"	108 lbs
QRU-12S-240-24CL	24	14-3/4" x 8-1/4" x 7"	102 lbs
	16	7-3/8" x 4-1/8" x 3"	
QRU-16S-220230240CL	18	10-7/8" x 5-1/2" x 5"	108 lbs
	12	14-3/4" x 8-1/4" x 7"	
Double Sided Rail System 36"L x 20"W x 53"H With Bins			
QRU-12D-220-192CL	192	7-3/8" x 4-1/8" x 3"	113 lbs
QRU-16D-230-96CL	96	10-7/8" x 5-1/2" x 5"	155 lbs
QRU-12D-240-48CL	48	14-3/4" x 8-1/4" x 7"	153 lbs
QRU-MOB		Mobilizes double sided units	25 lbs

Clear-View Mobile Double Sided Louvered Rack Unit

- Complete Packages

36"L x 25"W x 72"H Mobile unit 1,200 lb. capacity. Bins available in Clear.

MODEL NO.	NO. OF BINS	BIN DIMENSIONS L" x W" x H"	SHIP WGT
QMD-36H-220CL	240	7-3/8" x 4-1/8" x 3"	174 lbs
QMD-36H-230CL	120	10-7/8" x 5-1/2" x 5"	212 lbs
QMD-36H-240CL	56	14-3/4" x 8-1/4" x 7"	208 lbs
	72	10-7/8" x 5-1/2" x 5"	
QMD-36H-230240CL	24	14-3/4" x 8-1/4" x 7"	217 lbs

Clear-View Hang-and-Stack Bins

- Complete Steel Packages

Manufactured of FDA approved, heavy-duty tri-clear polypropylene allowing quick identification of the contents of any bin. See page 13 for accompanying dividers, clear window fronts and clear label holders.

MODEL NO.	NO. OF SHELVES	NO. OF BINS	BIN SIZE L" x W" x H"	SHIP WGT
12" x 36" x 75" Unit				
QSBU-239CL	8	28 QUS239CL	10-3/4" x 8-1/4" x 7"	99 lbs
QSBU-230240CL	10	36 QUS230CL 12 QUS240CL	10-7/8" x 5-1/2" x 5" 14-3/4" x 8-1/4" x 7"	122 lbs
QSBU-240CL	8	28 QUS240CL	14-3/4" x 8-1/4" x 7"	110 lbs
QSBU-245CL	7	24 QUS245CL	10-7/8" x 16-1/2" x 5"	111 lbs
QSBU-250CL	8	14 QUS250CL	14-3/4" x 16-1/2" x 7"	99 lbs
18" x 36" x 75" Unit				
QSBU-255CL	8	21 QUS255CL	16" x 11" x 8"	140 lbs
QSBU-260CL	6	15 QUS260CL	18" x 11" x 10"	120 lbs
QSBU-265CL	7	24 QUS265CL	18" x 8-1/4" x 9"	134 lbs
QSBU-270CL	6	10 QUS270CL	18" x 16-1/2" x 11"	117 lbs



COMPLETE PACKAGES
with bins!



QSBU-240CL
12"D x 36"W x 75"H
8 shelves and 28 QUS240
14-3/4"L x 8-1/4"W x 7"H bins

NEW! CLEAR-VIEW 24" CONTAINERS AND PACKAGES

Exclusive! Clear-View HULK 24" Containers

Organize and store your large and bulky items with these strong injection molded tri-clear polypropylene, stackable containers. These extra large stacking containers offer a generous 2 feet in length to store your larger items. Extra deep shelving and are available in a variety of widths and heights. Heavy-duty front, back and side grips allow for easy handling. Optional clear styrene plastic window increases bin capacity and provides a quick view of the bin contents. Optional dividers maximize flexibility and keep contents organized. Clear windows & dividers available on **page 22**. Wide stacking ledge and anti-slide lock keep stacked bins steady and prevent forward shifting. Waterproof bins resist rust and corrosion. Bins are autoclavable up to 250°F and are resistant to extreme cold. Color: Clear.

MODEL NO.	OUTSIDE DIMENSIONS L" x W" x H"	CTN QTY	CTN WGT
QUS950CL	23-7/8" x 8-1/4" x 7"	6	18 lbs
QUS951CL	23-7/8" x 8-1/4" x 9"	6	21 lbs
QUS952CL	23-7/8" x 11" x 7"	4	14 lbs
QUS953CL	23-7/8" x 11" x 10"	4	18 lbs
QUS954CL	23-7/8" x 16-1/2" x 11"	1	7 lbs
QUS964MOBCL	23-7/8" x 16-1/2" x 11"	1	9 lbs
QUS955CL	23-7/8" x 18-1/4" x 12"	1	8 lbs
QUS965MOBCL	23-7/8" x 18-1/4" x 12"	1	10 lbs

* With casters, overall height for mobile container will be increased by 3"



QUS950CL
23-7/8" L x 8-1/4" W x 7" H

COMPLETE PACKAGES with bins!



MOBILIZE YOUR WIRE SHELVING



DB - Donut Bumper

Non-marking donut bumper used to protect walls and help cushion impact.

WR-00H (Mobile Kit)*

Set of four swivel polyurethane 5" x 1-1/4" casters, two with brakes. Can be used with all units shown. 1,200 lb. load capacity.

*Mobile kits recommended only for shelves 18" and wider

HULK

WR6-953CL

24"W x 36"L x 74"H
6 shelves and 15 QUS953CL
23-7/8"L x 11"W x 10"H bins

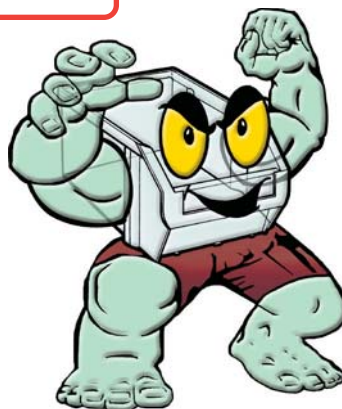

Clear-View HULK 24" - Complete Wire Packages

MODEL NO.	NO. OF SHELVES	NO. OF BINS	BIN SIZE L" x W" x H"	SHIP WGT
24" x 36" x 74" Unit				
WR8-950CL	8	28 QUS950CL	23-7/8" x 8-1/4" x 7"	205 lbs
WR8-950952CL	8	12 QUS950CL 12 QUS952CL	23-7/8" x 8-1/4" x 7" 23-7/8" x 11" x 7"	197 lbs
WR8-952CL	8	21 QUS952CL	23-7/8" x 11" x 7"	191 lbs
WR7-951CL	7	24 QUS951CL	23-7/8" x 8-1/4" x 9"	188 lbs
WR7-20-MIXCL	7	8 QUS950CL	23-7/8" x 8-1/4" x 7"	182 lbs
		4 QUS951CL	23-7/8" x 8-1/4" x 9"	
		3 QUS952CL	23-7/8" x 11" x 7"	
		3 QUS953CL	23-7/8" x 11" x 10"	
		2 QUS954CL	23-7/8" x 16-1/2" x 11"	
WR6-953CL	6	15 QUS953CL	23-7/8" x 11" x 10"	156 lbs
WR6-953954CL	6	9 QUS953CL	23-7/8" x 11" x 10"	159 lbs
		4 QUS954CL	23-7/8" x 16-1/2" x 11"	
WR6-954CL	6	10 QUS954CL	23-7/8" x 16-1/2" x 11"	164 lbs
24" x 42" x 74" Unit				
WR5-955CL	5	8 QUS955CL	23-7/8" x 18-1/4" x 12"	145 lbs

2475-954CL

24"D x 36"W x 75"H
6 shelves and 10 QUS954CL
23-7/8"L x 16-1/2"W x 11"H bins



Clear-View HULK 24" - Complete Steel Packages

MODEL NO.	NO. OF SHELVES	NO. OF BINS	BIN SIZE L" x W" x H"	SHIP WGT
24" x 36" x 75" Unit				
2475-950CL	8	28 QUS950CL	23-7/8" x 8-1/4" x 7"	213 lbs
2475-950952CL	8	12 QUS950CL 12 QUS952CL	23-7/8" x 8-1/4" x 7" 23-7/8" x 11" x 7"	205 lbs
2475-952CL	8	21 QUS952CL	23-7/8" x 11" x 7"	199 lbs
2475-951CL	7	24 QUS951CL	23-7/8" x 8-1/4" x 9"	195 lbs
2475-20MIXCL	7	8 QUS950CL	23-7/8" x 8-1/4" x 7"	189 lbs
		4 QUS951CL	23-7/8" x 8-1/4" x 9"	
		3 QUS952CL	23-7/8" x 11" x 7"	
		3 QUS953CL	23-7/8" x 11" x 10"	
		2 QUS954CL	23-7/8" x 16-1/2" x 11"	
2475-953CL	6	15 QUS953CL	23-7/8" x 11" x 10"	163 lbs
2475-953954CL	6	9 QUS953CL	23-7/8" x 11" x 10"	166 lbs
		4 QUS954CL	23-7/8" x 16-1/2" x 11"	
2475-954CL	6	10 QUS954CL	23-7/8" x 16-1/2" x 11"	171 lbs



NEW! CLEAR-VIEW SHELF BINS AND PACKAGES

Exclusive! Clear-View Economy Shelf Bins

Quantum's tough, durable, high density Shelf Bins are the industry standard for quality. These durable tri-clear polypropylene bins feature a molded-in label holder, built-in rear hanglock which allows bins to tilt out for complete access when on shelving. A wide hopper front allows complete access to the contents of the bin. Edges are reinforced for added strength. They are designed for 12", 18" and 24" deep shelf units, racks or standard shelving. Bins are impervious to most chemicals. Color: Clear.



QSB106CL

23-5/8"L x 6-5/8"W x 4"H



WR6-36-1236-109CL

12"W x 36"L x 36"H



WR12-107CL

12"W x 36"L x 74"H



MOBILIZE YOUR WIRE SHELVING



DB - Donut Bumper
Non-marking donut bumper used to protect walls and help cushion impact.

WR-00H (Mobile Kit)*
Set of four swivel polyurethane 5" x 1-1/4" casters, two with brakes. Can be used with all units shown. 1,200 lb. load capacity.
*Mobile kits recommended only for shelves 18" and wider



MODEL NO.	OUTSIDE DIMENSIONS L" x W" x H"	CTN QTY	CTN WGT
QSB100CL	11-5/8" x 2-3/4" x 4"	36	13 lbs
QSB101CL	11-5/8" x 4-1/8" x 4"	36	17 lbs
QSB102CL	11-5/8" x 6-5/8" x 4"	30	18 lbs
QSB107CL	11-5/8" x 8-3/8" x 4"	20	15 lbs
QSB109CL	11-5/8" x 11-1/8" x 4"	8	7 lbs
QSB103CL	17-7/8" x 4-1/8" x 4"	20	13 lbs
QSB104CL	17-7/8" x 6-5/8" x 4"	20	16 lbs
QSB108CL	17-7/8" x 8-3/8" x 4"	10	11 lbs
QSB110CL	17-7/8" x 11-1/8" x 4"	8	11 lbs
QSB105CL	23-5/8" x 4-1/8" x 4"	16	13 lbs
QSB106CL	23-5/8" x 6-5/8" x 4"	8	9 lbs
QSB114CL	23-5/8" x 8-3/8" x 4"	6	9 lbs
QSB116CL	23-5/8" x 11-1/8" x 4"	6	10 lbs

Individual labels are available for all Shelf Bins. Ctn Qty: 50 Individual Labels For label Model No. substitute "L" for "Q" in bin Model No.

Clear-View Complete Bin Center

Complete bin systems are available with 4 different size bins on a 12"W x 36"L x 36"H unit. This all-purpose bin center is an economical high density storage system that provides easy visibility to stored contents.

MODEL NO.	NO. OF BINS	BIN SIZE L" x W" x H"	SHIP WGT
12" x 36" x 36" Unit, 6 Shelves			
WR6-36-1236-101CL	40 QSB101CL	11-5/8" x 4-1/8" x 4"	63 lbs
WR6-36-1236-102CL	25 QSB102CL	11-5/8" x 6-5/8" x 4"	50 lbs
WR6-36-1236-107CL	20 QSB107CL	11-5/8" x 8-3/8" x 4"	62 lbs
WR6-36-1236-109CL	15 QSB109CL	11-5/8" x 11-1/8" x 4"	64 lbs

COMPLETE PACKAGES with bins!

Clear-View Economy Shelf Bins - Complete Wire Packages

Manufactured of FDA approved, heavy-duty tri-clear polypropylene allowing quick identification of the contents of any bin.

MODEL NO.	NO. OF BINS	BIN SIZE L" x W" x H"	SHIP WGT
12" x 36" x 74" Unit, 12 Shelves			
WR12-101CL	77 QSB101CL	11-5/8" x 4-1/8" x 4"	114 lbs
WR12-102CL	55 QSB102CL	11-5/8" x 6-5/8" x 4"	116 lbs
WR12-107CL	44 QSB107CL	11-5/8" x 8-3/8" x 4"	117 lbs
WR12-109CL	33 QSB109CL	11-5/8" x 11-1/8" x 4"	119 lbs
18" x 36" x 74" Unit, 12 Shelves			
WR12-103CL	77 QSB103CL	17-7/8" x 4-1/8" x 4"	169 lbs
WR12-104CL	55 QSB104CL	17-7/8" x 6-5/8" x 4"	165 lbs
WR12-108CL	44 QSB108CL	17-7/8" x 8-3/8" x 4"	170 lbs
WR12-110CL	33 QSB110CL	17-7/8" x 11-1/8" x 4"	168 lbs
24" x 36" x 74" Unit, 12 Shelves			
WR12-105CL	77 QSB105CL	23-5/8" x 4-1/8" x 4"	219 lbs
WR12-106CL	55 QSB106CL	23-5/8" x 6-5/8" x 4"	218 lbs
WR12-114CL	44 QSB114CL	23-5/8" x 8-3/8" x 4"	222 lbs
WR12-116CL	33 QSB116CL	23-5/8" x 11-1/8" x 4"	206 lbs

NEW! CLEAR-VIEW SHELF BINS AND PACKAGES

Clear-View Shelf Bin Sloped Shelving Systems - Complete Packages

Pick Racks provide a convenient high density, easy access, sloped shelving system, available as bench units, single and double sided free standing and mobile units. Unit comes complete with Economical Shelf Bins. Sloped shelving unit keeps small and medium sized parts easily accessible. Open hopper front bins with label area, provide fast access to stored items. This all-in-one unit is easy to clean and will not rust or corrode. See chart for configurations. Bins are available in Clear.

MODEL NO.	NO. OF BINS	BIN SIZE L" x W" x H"	SHIP WGT
BENCH RACKS 12" x 36" x 21" Unit, 3 Shelves			
QPRHA-100CL	36 QSB100CL	11-5/8" x 2-3/4" x 4"	41 lbs
QPRHA-101CL	24 QSB101CL	11-5/8" x 4-1/8" x 4"	38 lbs
QPRHA-102CL	15 QSB102CL	11-5/8" x 6-5/8" x 4"	36 lbs
QPRHA-107CL	12 QSB107CL	11-5/8" x 8-3/8" x 4"	36 lbs
QPRHA-109CL	9 QSB109CL	11-5/8" x 11-1/8" x 4"	37 lbs
SINGLE SIDED RACKS 12" x 36" x 60" Unit, 8 Shelves			
QPRS-100CL	96 QSB100CL	11-5/8" x 2-3/4" x 4"	99 lbs
QPRS-101CL	64 QSB101CL	11-5/8" x 4-1/8" x 4"	85 lbs
QPRS-102CL	40 QSB102CL	11-5/8" x 6-5/8" x 4"	80 lbs
QPRS-107CL	32 QSB107CL	11-5/8" x 8-3/8" x 4"	81 lbs
QPRS-109CL	24 QSB109CL	11-5/8" x 11-1/8" x 4"	83 lbs
DOUBLE SIDED RACK 24" x 36" x 60" Unit, 16 Shelves			
QPRD-100CL	192 QSB100CL	11-5/8" x 2-3/4" x 4"	195 lbs
QPRD-101CL	128 QSB101CL	11-5/8" x 4-1/8" x 4"	169 lbs
QPRD-102CL	80 QSB102CL	11-5/8" x 6-5/8" x 4"	158 lbs
QPRD-107CL	64 QSB107CL	11-5/8" x 8-3/8" x 4"	160 lbs
QPRD-109CL	48 QSB109CL	11-5/8" x 11-1/8" x 4"	163 lbs
QDU-00	MOBILE KIT - Mobilizes all double sided units		

Twelve QSB100, eight QSB101CL, five QSB102CL, four QSB107CL, three QSB109CL, six QUS230CL, three QUS235CL, and two QUS245CL fit across a standard 36" wide pick rack shelf.



Clear-View Shelf Bin - Complete Steel Packages

MODEL NO.	NO. OF BINS	BIN SIZE L" x W" x H"	SHIP WGT
12" x 36" x 75" Unit, 13 Shelves			
1275-100CL	144 QSB100CL	11-5/8" x 2-3/4" x 4"	139 lbs
1275-101CL	96 QSB101CL	11-5/8" x 4-1/8" x 4"	117 lbs
1275-102CL	60 QSB102CL	11-5/8" x 6-5/8" x 4"	115 lbs
1275-107CL	48 QSB107CL	11-5/8" x 8-3/8" x 4"	120 lbs
1275-109CL	36 QSB109CL	11-5/8" x 11-1/8" x 4"	119 lbs
12" x 36" x 39" Unit, 7 Shelves			
1239-100CL	72 QSB100CL	11-5/8" x 2-3/4" x 4"	75 lbs
1239-101CL	48 QSB101CL	11-5/8" x 4-1/8" x 4"	67 lbs
1239-102CL	30 QSB102CL	11-5/8" x 6-5/8" x 4"	63 lbs
1239-107CL	24 QSB107CL	11-5/8" x 8-3/8" x 4"	64 lbs
1239-109CL	18 QSB109CL	11-5/8" x 11-1/8" x 4"	65 lbs
18" x 36" x 75" Unit, 13 Shelves			
1875-103CL	96 QSB103CL	17-7/8" x 4-1/8" x 4"	161 lbs
1875-104CL	60 QSB104CL	17-7/8" x 6-5/8" x 4"	155 lbs
1875-108CL	48 QSB108CL	17-7/8" x 8-3/8" x 4"	161 lbs
1875-110CL	36 QSB110CL	17-7/8" x 11-1/8" x 4"	158 lbs
18" x 36" x 39" Unit, 7 Shelves			
1839-103CL	48 QSB103CL	17-7/8" x 4-1/8" x 4"	87 lbs
1839-104CL	30 QSB104CL	17-7/8" x 6-5/8" x 4"	84 lbs
1839-108CL	24 QSB108CL	17-7/8" x 8-3/8" x 4"	87 lbs
1839-110CL	18 QSB110CL	17-7/8" x 11-1/8" x 4"	86 lbs

SLOPED SHELVES! Easy Access!



QPRHA-100CL

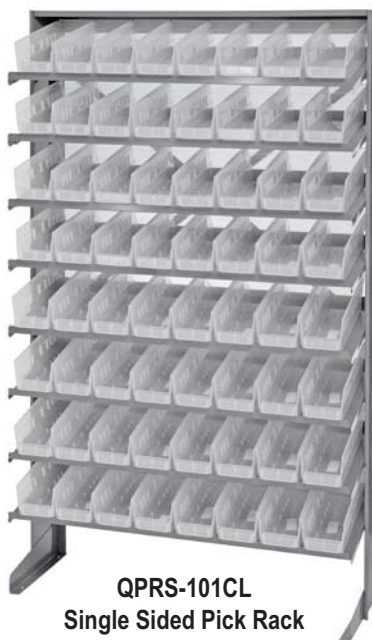

QPRS-101CL
Single Sided Pick Rack



QPRD-109CL
Double Sided Pick Rack

COMPLETE PACKAGES with bins!

**LOWEST
PRICE
GUARANTEED!**



1239-107CL
12"D x 36"W x 39"H



1275-102CL
12"D x 36"L x 75"H

NEW! CLEAR-VIEW GIANT STACK CONTAINERS

Clear-View Giant Stack Containers

Multipurpose, wide open hopper front provides easy access for large part storage. Ideal for multiple applications in recycling, storing parts, tools and warehouse items. This bin will stack up to 6 bins high creating a sturdy, tall storage system. Injection molded from high density tri-clear polypropylene, easy to clean, resists rust and corrosion and impervious to most chemicals. Large label holder allows for quick identification. Optional clear window increases storage capacity and allows for inspection of parts. Six 1/4" drill hole pattern on bottom of bin allows for easy hole insertion for drainage. Available in Clear.

MODEL NO.	OUTSIDE DIMENSIONS L" x W" x H"	CTN QTY	CTN WGT	WINDOW	CTN QTY
QGH600CL	17-1/2" x 10-7/8" x 12-1/2"	4	12	WGH600	4
QGH700CL*	15-1/4" x 19-7/8" x 12-7/16"	3	13	WGH700	3
QGH800CL	17-1/2" x 16-1/2" x 12-1/2"	2	8	WGH800	2

* Optional label for QGH700CL is available, LGH700 (3 per package)



QGH700CL



QGH705MOBCL



Clear-View Mobile Giant Stack Containers

- Ideal for transport of heavy and bulky parts
- Container comes with 4 swivel, 3" casters, all with brakes, allowing for up to 250 lb. mobile load capacity
- Containers can stack with casters in place
- Available in Clear

MODEL NO.	OUTSIDE DIMENSIONS L" x W" x H"	CTN QTY	CTN WGT
QGH705MOBCL	15-1/4" x 19-7/8" x 12-7/16"	3	22
QGH805MOBCL	17-1/2" x 16-1/2" x 12-1/2"	2	17

* With casters, overall height for mobile container will be increased by 3"



**LOWEST
PRICE
GUARANTEED!**

MOBILIZE YOUR WIRE SHELVING



DB - Donut Bumper

Non-marking donut bumper used to protect walls and help cushion impact.

WR-00H (Mobile Kit)*

Set of four swivel polyurethane 5" x 1-1/4" casters, two with brakes. Can be used with all units shown. 1,200 lb. load capacity.

*Mobile kits recommended only for shelves 18" and wider

WR5-600

18"W x 36"L x 74"H

5 shelves & 12 QGH600CL bins

COMPLETE PACKAGES with bins!



QSBU-700

18"D x 42"W x 75"H
6 shelves & 10 QGH700CL bins



Clear-View Bin Storage Center - Complete Steel Packages

Organize, store and access your medium or large parts with this high capacity bin center. 475 lb. capacity per shelf and over 21 cubic feet of storage space. Smooth powder coat finish and cross bracing for increased stability. Easy assembly. Available in Clear.

Clear-View Giant Stack - Complete Wire Packages

MODEL NO.	NO. OF BINS	BIN SIZE L" x W" x H"	SHIP WGT
18" x 36" x 74" Unit, 5 Shelves			
WR5-600CL	12 QGH600CL	17-1/2" x 10-7/8" x 12-1/2"	104 lbs
WR5-600800CL	6 QGH600CL 4 QGH800CL	17-1/2" x 10-7/8" x 12-1/2" 17-1/2" x 16-1/2" x 12-1/2"	103 lbs
WR5-800CL	8 QGH800CL	17-1/2" x 16-1/2" x 12-1/2"	102 lbs
18" x 42" x 74" Unit, 5 Shelves			
WR5-700CL	8 QGH700CL	15-1/4" x 19-7/8" x 12-7/16"	98 lbs

MODEL NO.	NO. OF BINS	BIN SIZE L" x W" x H"	SHIP WGT
18" x 36" x 75" Unit, 6 Shelves			
QSBU-600CL	15 QGH600CL	17-1/2" x 10-7/8" x 12-1/2"	116 lbs
QSBU-600800CL	6 QGH600CL 6 QGH800CL	17-1/2" x 10-7/8" x 12-1/2" 17-1/2" x 16-1/2" x 12-1/2"	114 lbs
QSBU-800CL	10 QGH800CL	17-1/2" x 16-1/2" x 12-1/2"	113 lbs
18" x 42" x 75" Unit, 6 Shelves			
QSBU-700CL	10 QGH700CL	15-1/4" x 19-7/8" x 12-7/16"	123 lbs

NEW! CLEAR-VIEW DIVIDABLE GRID CONTAINERS

Clear-View Dividable Grid Containers

Heavy-duty Dividable Grid Containers can be used for storage, kitting and distribution applications. These containers offer the safest and most efficient method for compartmentalizing and protecting small to medium sized items. Dividers allow you to customize the container's interior to meet your exact needs. Dividers: Gray. Containers and covers are available in Clear.

MODEL NO.	OUTSIDE DIMENSIONS L" x W" x H"	INSIDE DIMENSIONS L" x W" x H"	CTN QTY	CTN WGT
DG91035CL	10-7/8" x 8-1/4" x 3-1/2"	9-3/16" x 6-9/16" x 3"	20	24 lbs
DG91050CL	10-7/8" x 8-1/4" x 5"	9-3/16" x 6-9/16" x 4-1/2"	20	32 lbs
DG92035CL	16-1/2" x 10-7/8" x 3-1/2"	14-7/8" x 9-1/4" x 3"	12	23 lbs
DG92060CL	16-1/2" x 10-7/8" x 6"	14-7/8" x 9-1/4" x 5-1/2"	8	20 lbs
DG92080CL	16-1/2" x 10-7/8" x 8"	14-7/8" x 9-1/4" x 7-1/2"	8	27 lbs
DG93030CL	22-1/2" x 17-1/2" x 3"	20-5/8" x 15-5/8" x 2-1/2"	6	20 lbs
DG93060CL	22-1/2" x 17-1/2" x 6"	20-5/8" x 15-5/8" x 5-1/2"	3	19 lbs
DG93080CL	22-1/2" x 17-1/2" x 8"	20-5/8" x 15-5/8" x 7-1/2"	3	16 lbs
DG93120CL	22-1/2" x 17-1/2" x 12"	20-5/8" x 15-5/8" x 11-1/2"	3	23 lbs



DG92080CL

Shown with optional dividers
(Sold separately) See page 70



WR7-92080CL



Chrome Wire Shelving System with Clear-View Dividable Grid Containers - Complete Packages

Same durable chrome wire shelving combined with Quantum's Clear-View Dividable Grid Containers. These containers allow for multiple compartment configurations within each bin. Offering four different packages, these systems are ideal for small, medium and large parts storage. Unit may be made mobile with the addition of the WR-00H mobile kit. See catalog page 70 for additional information and to order optional accessories.

MODEL NO.	NO. OF SHELVES	NO. OF BINS	BIN DIMENSIONS L" x W" x H"	SHIP WGT
18" x 48" x 74" Wire Shelving Unit with Clear Dividable Grid Containers				
WR9-92060CL	9	36 DG92060CL	16-1/2" x 10-7/8" x 6"	210 lbs
WR7-92080CL	7	24 DG92080CL	16-1/2" x 10-7/8" x 8"	174 lbs
24" x 60" x 63" Wire Shelving Unit with Clear Dividable Grid Containers				
WR12-93030CL	12	36 DG93030CL	22-1/2" x 17-1/2" x 3"	274 lbs
24" x 60" x 74" Wire Shelving Unit with Clear Dividable Grid Containers				
WR9-93060CL	9	24 DG93060CL	22-1/2" x 17-1/2" x 6"	254 lbs



Clear Dust Cover Inlays

MODEL NO.	FITS BIN MODEL NO.	CTN QTY
DDC91000CL	DG91035, DG91050	10
DDC92000CL	DG92035, DG92060, DG92080	4
DDC93000CL	DG93030, DG93060, DG93080, DG93120	3

Bin Cart with Clear-View Dividable Grid Containers

MODEL NO.	NO. OF BINS	BIN DIMENSIONS L" x W" x H"	SHIP WGT
24"W x 36"L x 69"H Bin Cart with Clear Dividable Grids			
WRC5-63-2436-93060CL	4 DG93060CL	22-1/2" x 17-1/2" x 6"	113 lbs
24"W x 48"L x 69"H Bin Cart with Clear Dividable Grids			
WRC5-63-2448-93060CL	4 DG93060CL	22-1/2" x 17-1/2" x 6"	128 lbs
24"W x 60"L x 69"H Bin Cart with Clear Dividable Grids			
WRC5-63-2460-93060CL	4 DG93060CL	22-1/2" x 17-1/2" x 6"	153 lbs

MODEL NO.	NO. OF BINS	BIN DIMENSIONS L" x W" x H"	SHIP WGT
Bin Cart with Clear Dividable Grid Containers 21"W x 24"L x 45"H			
BC212434M1CL	4 DG93060CL	22-1/2" x 17-1/2" x 6"	58 lbs
Bin Cart with Clear Dividable Grid Containers 21"W x 24"L x 69"H			
BC212469M1CL	7 DG93060CL	22-1/2" x 17-1/2" x 6"	68 lbs
BC212469M2CL	11 DG93030CL	22-1/2" x 17-1/2" x 3"	84 lbs
Bin Cart with NO Containers (includes slides for 7 bin levels) 21"W x 24"L x 69"H			
BC212469M	--	--	50 lbs
One Pair - 24" Wire Bin Slides			
WR-S24W	--	--	3 lbs



Clear Dust Cover Inlays
Clear Dust Cover Acrylic Inlays keep stored items visible while protecting against airborne dust and other contaminants. Cover inlays inside on rim of container.

**LOWEST
PRICE
GUARANTEED!**



BC212434M1CL

BIN, TOTE AND CONTAINER LABELS

Bin, Totes and Container Labels

Clear Label Holder Kits allow for easy parts identification and bar coding of the bin contents. Laser and inkjet compatible inserts come in 8-1/2" x 11" perforated sheets. Label holders easily slide into molded-in label slot on bin to protect label. Kit contains 25 clear holders and corresponding printer friendly sheet labels.



Clear Label Holder

Clear label holders and laser label inserts are available for Ultra Stack & Hang Bins. Labels are inserted inside clear sleeve for maximum protection. Package of 25.

Ultra Stack & Hang Bins
page 13



Clear Label Holder

Clear Label Holders are available for Economy Shelf Bins & STORE-MORE Shelf Bins. Laser & Inkjet compatible inserts. Label holders fit all shelf bins (except QSB100). Package of 25. Model No.: LTR-0813

Shelf Bins page 41
STORE-MORE page 46

Individual Labels

Individual Label Inserts are pre-cut to slide into molded-in label slot on bin fronts. Package of 50 individual cut labels (not intended for printer use).



Ultra Stack & Hang Bins
page 13



Giant Stack Containers
page 30



Shelf Bins page 41
STORE-MORE page 46



10° Angle



45° Angle

Extended Label Holders - simplify identification!

Optional extended label holders are designed for larger bar code scanning. Label holders fit all Shelf Bins & STORE-MORE Shelf Bins (except QSB100).

Shelf Bins page 41
STORE-MORE page 46



Clear Label Holder

Fits any size containers. Three sizes to choose from. Also available for conductive containers. Package of 6.



Conductive



Conductive Dividable Grid Containers
page 57

Dividable Grid Containers
page 70



Clear Adhesive Label Holder
3" x 5" adhesive clear label holder attaches securely to container for easy part identification. Creates a sleeve for up to 3" x 5" label. Package of 24. Model No.: QDL-2115

Attached Top Containers
page 73



Clear Label Holder

Fits all nine sizes of stack and nest totes have ability to use the optional clear label holder. 3" x 5" clear label holder securely attaches to tote with or without lid for easy part identification. Package of 6. Model No.: snh010.

GENUINE stack and nest totes
page 68



Clear Label Holder

Fits all five cross stack tub sizes. 3" x 5" clear label holder securely attaches to tote with or without lid for easy part identification. Package of 6. Model No.: snh010

Cross Stack Tubs
page 71

ULTRA STACK AND HANG BINS

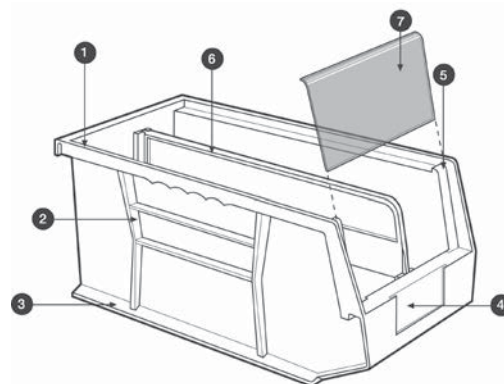

1. Full width hanger supports bin when hanging from louvered panels or rails
2. Reinforced rib design adds strength and prevents spreading
3. Extra-wide stacking ledge for secure stacking
4. Large front label slot allows larger bar code scanning and content identification
5. Anti-slide stop prevents stacked bins from shifting forward
6. Optional dividers increase storage options
7. Optional windows maximize storage capacity, prevent spillage and protects parts from dust and dirt

PERFORMANCE FEATURES AT A GLANCE:

- Available in 20 sizes
- Standard colors: Blue, Yellow, Red, Green, Ivory, Black and Clear (additional colors available on request, subject to up charge and minimum runs)
- Bins are made from heavy-duty, virgin, high density FDA approved polypropylene
- Large multiple label slots provide easy label insertion and parts identification
- Extra wide stacking ledge assures stability for high stacking
- Reinforced design adds strength and prevents spreading
- Will not rust or corrode, unaffected by weak acids and alkalis, and are waterproof
- Autoclavable up to 250°F
- Interchangeable with other manufactured brands of bins

**LOWEST
PRICE
GUARANTEED!**



**QUS275MOB
Mobile Ultra Bin**

- Ideal for transport of heavy and bulky parts
- Bin comes with 4 swivel, 3" casters, all of which have brakes, allowing for up to 250 lb. mobile load capacity

Clear Label Holder

Clear label holders and laser label inserts are available for Ultra Stack & Hang Bins. Label are inserted inside clear sleeve for maximum protection. Package of 25.



QUS240
Shown with Optional
Divider and Window

**Fastest
Shipping
IN THE INDUSTRY**

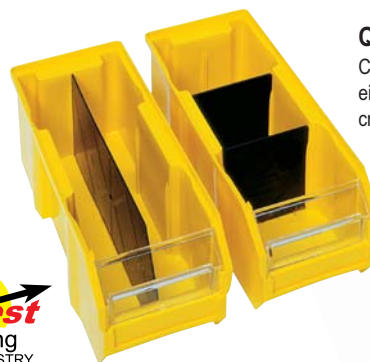

QUS233

Can be used with
either length or
cross divider



DLY-3018
(Bin sold separately)

HANDLE-DLY

32" Dolly Pull Rod
with handle



Attached pull ring allows dolly
to be pulled with ease



Plastic Mobile Dolly

DLY-3018 Dolly with Padded Rubber Trim, available in Blue. 1,000 lb. capacity. Interior Dimensions 22-3/8"L x 16"W Exterior Dimensions 30"L x 18"W

MODEL NO.	DESCRIPTION	CTN WGT
DLY-3018	Dolly with Padded Rubber Trim	19 lbs
HANDLE-DLY	32" Dolly Pull Rod with Handle	2 lbs

Bins sold separately.

ULTRA STACK AND HANG BINS

Ultra Stack and Hang Bins

Organize your inventory with strong injection molded plastic bins. Front, back and side grips for easy handling. Built in rear hanger allows bins to hang from louvered panels or rails. Optional clear plastic window increases bin capacity and provides quick view of bin contents. Dividers maximize flexibility and keep contents organized. Wide stacking ledge and anti-slide lock keep stacked bins steady and prevent forward shifting. Waterproof bins resist rust and corrosion. Large molded front label slots for ID labels. Autoclavable up to 250°F and resistant to extreme cold. Available in Blue, Yellow, Red, Green, Ivory and Black. See page 4 to order Clear Bins.

7 colors, 20 sizes
- the LARGEST selection
anywhere!

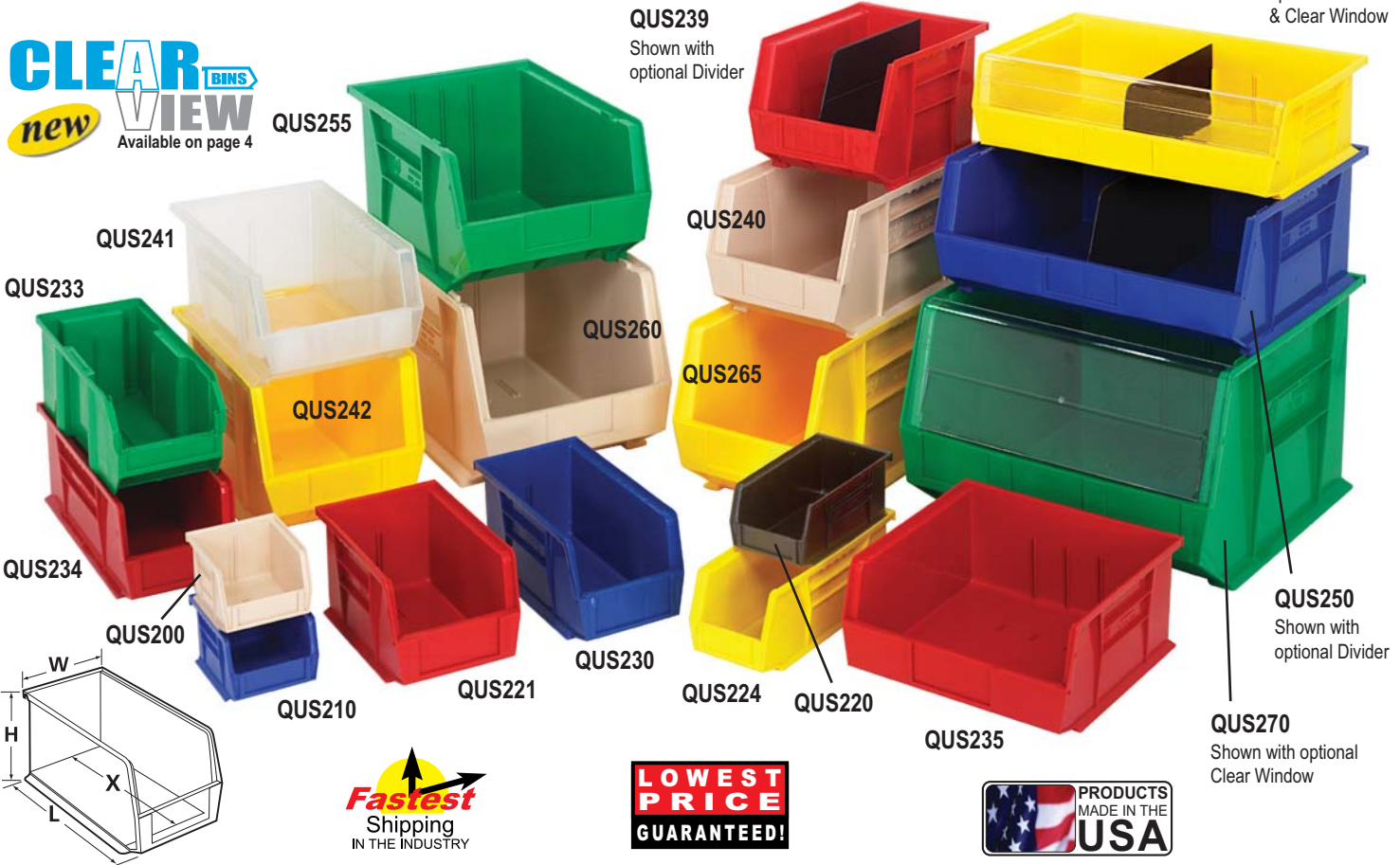

Fastest
Shipping
IN THE INDUSTRY

LOWEST
PRICE
GUARANTEED!



MODEL NO.	OUTSIDE DIMENSIONS L" x W" x H"	INSIDE DIMENSIONS L" x W" x H"	X"	CTN QTY	CTN WGT	BIN LOAD CAPACITY*	CLEAR WINDOW	CTN QTY	DIVIDER	CTN QTY	NUMBER OF DIVIDER SLOTS	CLEAR LABEL HOLDER
QUS200	5" x 4-1/8" x 3"	4-3/8" x 3-7/16" x 2-13/16"	3-1/2"	24	5 lbs	8 lbs	-	-	DUS200	6	1	LTR-1300
QUS210	5-3/8" x 4-1/8" x 3"	4-3/4" x 3-7/16" x 2-13/16"	4"	24	6 lbs	10 lbs	-	-	DUS210	6	1	LTR-1300
QUS220	7-3/8" x 4-1/8" x 3"	6-3/4" x 3-7/16" x 2-13/16"	6"	24	8 lbs	10 lbs	-	-	DUS220	6	1	LTR-1300
QUS221	9-1/4" x 6" x 5"	8-1/2" x 5-1/8" x 4-1/2"	7-1/4"	12	6 lbs	20 lbs	WUS221	12	DUS221	6	1	LTR-1754
QUS224	10-7/8" x 4-1/8" x 4"	10-1/4" x 3-3/16" x 3-3/4"	9"	12	8 lbs	30 lbs	WUS224	12	DUS224	6	1	LTR-1253
QUS230	10-7/8" x 5-1/2" x 5"	10-1/4" x 4-3/8" x 4-3/4"	9"	12	10 lbs	30 lbs	WUS230/234	12	DUS230/235	6	1	LTR-1754
QUS233	13-1/2" x 5-1/2" x 5"	11-1/4" x 4-3/8" x 4-3/4"	10-1/4"	12	13 lbs	30 lbs	WUS233	12	DUS233	6	1	-
									CDUS233**	6		
QUS234	14-3/4" x 5-1/2" x 5"	14-1/16" x 4-3/8" x 4-3/4"	12-13/16"	12	14 lbs	50 lbs	WUS230/234	12	DUS234	6	1	LTR-1754
QUS235	10-7/8" x 11" x 5"	10-1/4" x 10" x 4-3/4"	9"	6	10 lbs	50 lbs	WUS235	6	DUS230/235	6	3	LTR-1754
QUS239	10-3/4" x 8-1/4" x 7"	10" x 6-9/16" x 6-3/4"	8"	6	10 lbs	50 lbs	WUS239/240	6	DUS239	6	1	LTR-1754
QUS240	14-3/4" x 8-1/4" x 7"	14" x 6-9/16" x 6-3/4"	12"	12	24 lbs	60 lbs	WUS239/240	6	DUS240/250	6	1	LTR-1754
QUS241	13-5/8" x 8-1/4" x 6"	12-1/2" x 6-3/4" x 5-3/8"	11-1/8"	12	22 lbs	60 lbs	WUS241	12	DUS241	6	1	LTR-1754
QUS242	13-5/8" x 8-1/4" x 8"	12-1/2" x 6-3/4" x 7-3/8"	11-1/8"	12	25 lbs	60 lbs	WUS242	12	DUS242	6	1	LTR-1754
QUS245	10-7/8" x 16-1/2" x 5"	9-3/4" x 15" x 4-3/4"	9"	6	13 lbs	60 lbs	WUS245	6	DUS245	6	3	LTR-1754
QUS250	14-3/4" x 16-1/2" x 7"	14" x 14-3/4" x 6-3/4"	12"	6	21 lbs	75 lbs	WUS250	6	DUS240/250	6	3	LTR-1754
QUS255	16" x 11" x 8"	15-1/8" x 10" x 7-3/4"	11-5/8"	4	14 lbs	75 lbs	WUS255	4	DUS255	6	3	LTR-1754
QUS260	18" x 11" x 10"	17" x 9-1/2" x 9-3/4"	14-3/16"	4	17 lbs	75 lbs	WUS260	4	DUS260	6	3	LTR-1754
QUS265	18" x 8-1/4" x 9"	17-1/8" x 6-3/4" x 8-1/4"	14-1/2"	6	17 lbs	60 lbs	WUS265	6	DUS265	6	1	LTR-1754
QUS270	18" x 16-1/2" x 11"	17-1/8" x 14-3/4" x 10-1/4"	14"	3	16 lbs	75 lbs	WUS270	3	DUS270	6	3	LTR-2400
QUS275MOB	18" x 16-1/2" x 11"****	17-1/8" x 14-3/4" x 10-1/4"	14"	3	25 lbs	-	WUS270	3	DUS270	6	3	LTR-2400

* When attached to panels or rails ** Indicates cross divider *** With casters, overall height is 14" Individual labels are available for all Ultra Bins. For label Model No., substitute "L" for "Q" in bin Model No. Ctn Qty: 50 Individual Labels

LOUVERED PANELS

Ultra Hanging Systems

Quantum Ultra bins will hang on louvered panels or rail hanging systems in a wide range of configurations designed to meet all application needs. Hanging Systems are either: Wall Mounted, Table Top, Free Standing or Mobile Units. Use the system best suited to your needs with your choice of Ultra Bins. Systems are formed from heavy-duty 16 gauge cold rolled steel and have a Gray baked-enamel finish which ensures years of heavy-duty use. Louvered panels may be mounted on any suitable surface including walls, benches, inside service trucks and cabinets or on carts. Fasten securely to assure adequate load bearing. Louvered Systems are available as Bench Units (in 4 sizes), Free Standing Single and Double Sided Units and Mobile Units.



QLP-1819

18"L x 19"H

Accepts all sizes of Ultra Bins.
175 lb. load capacity.
(Bins sold separately)

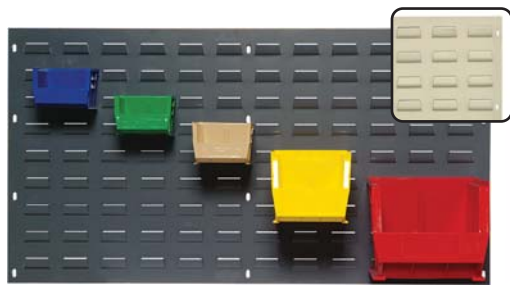

QLP-3619

36"L x 19"H

Accepts all sizes of Ultra Bins.
175 lb. load capacity.
(Bins sold separately)



QLP-4819

48"L x 19"H

Accepts all sizes of Ultra Bins.
250 lb. load capacity.
(Bins sold separately)

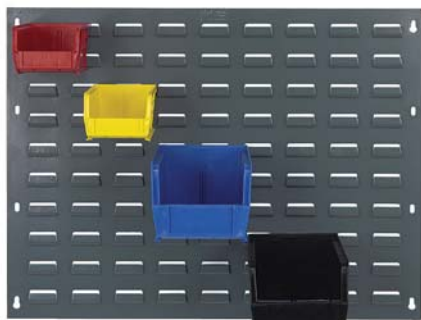

QLP-2721

27"L x 21"H

Accepts all sizes of Ultra Bins.
175 lb. load capacity.
(Bins sold separately)

**Available
in Gray or
Beige***

*Select Sizes
Indicated



QLP-3612

36"L x 12"H

Accepts all sizes of Ultra Bins.
175 lb. load capacity.
(Bins sold separately)

**Customize
your own unit!**

1. Select the louvered panel of your choice.
2. See page 13 and choose the bin that best fits your need.
3. Go to the chart at the bottom of page 15 and determine how many bins fit on the unit you selected.
4. Place your order for both unit and bins (Bins sold in carton quantities).

Fastest
Shipping
IN THE INDUSTRY

**LOWEST
PRICE
GUARANTEED!**



QLP-1861

18"L x 61"H

Accepts all sizes of Ultra Bins.
250 lb. load capacity.
(Bins sold separately)

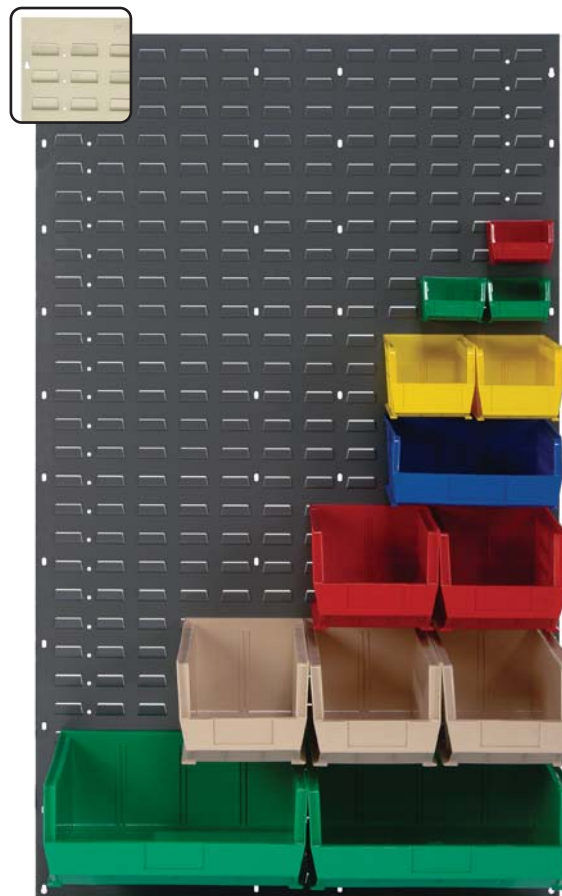

QLP-3661

36"L x 61"H

Accepts all sizes of Ultra Bins.
500 lb. load capacity.
(Bins sold separately)

MODEL NO.	DIMENSIONS L" x H"	CTN QTY	CTN WGT
QLP-1819*	18" x 19" Louvered Panel	1	6 lbs
QLP-1861*	18" x 61" Louvered Panel	1	21 lbs
QLP-2721	27" x 21" Louvered Panel	1	11 lbs
QLP-3612	36" x 12" Louvered Panel	1	8 lbs
QLP-3619*	36" x 19" Louvered Panel	1	13 lbs
QLP-3661*	36" x 61" Louvered Panel	1	40 lbs
QLP-4819	48" x 19" Louvered Panel	1	18 lbs
QLP-4861*	48" x 61" Louvered Panel	1	60 lbs

*Available in Gray or Beige color. To order a Beige Louvered Panel add BG to the model number (i.e. QLP-1819BG).

LOUVERED PANELS & BENCH RACKS



QBR-1819

18"L x 8"W x 19"H
Accepts all sizes of Ultra Bins.
140 lb. load capacity.
(Bins sold separately)

Customize your own unit!

1. Select the bench rack of your choice.
2. See page 13 and choose the bin that best fits your need.
3. Go to the chart at the bottom of this page and determine how many bins fit on the unit you selected.
4. Place your order for both unit and bins (Bins sold in carton quantities).

Fastest
Shipping
IN THE INDUSTRY

**LOWEST
PRICE
GUARANTEED!**

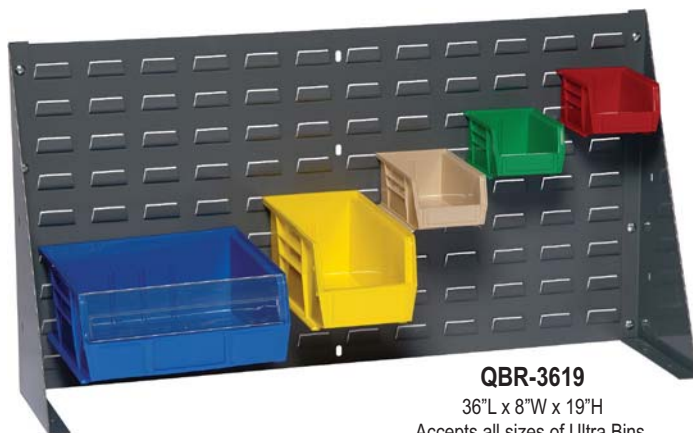

QBR-3619

36"L x 8"W x 19"H
Accepts all sizes of Ultra Bins.
150 lb. load capacity.
(Bins sold separately)

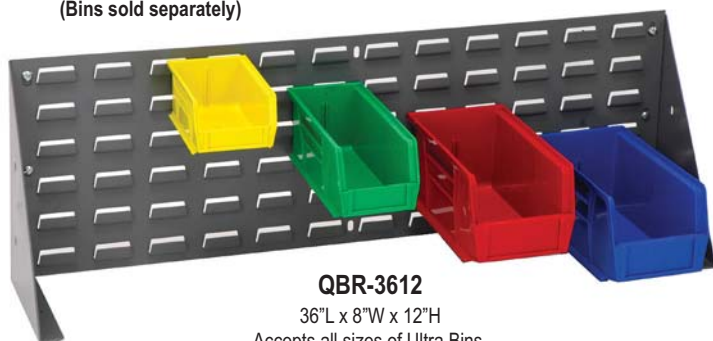

QBR-3612

36"L x 8"W x 12"H
Accepts all sizes of Ultra Bins.
125 lb. load capacity.
(Bins sold separately)

MODEL NO.	DIMENSIONS L" x W" x H"	CTN QTY	CTN WGT
QBR-1819	18" x 8" x 19" Bench Rack	1	18 lbs
QBR-2721	27" x 8" x 21" Bench Rack	1	116 lbs
QBR-3612	36" x 8" x 12" Bench Rack	1	114 lbs
QBR-3619	36" x 8" x 19" Bench Rack	1	119 lbs



QBR-1819



QBR-3612



QLP-2721



QLP-3612



QLP-4819



QLP-1861

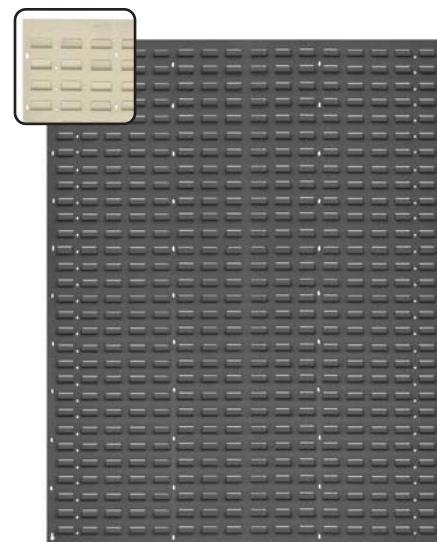

QLP-4861

QUANTITY OF ULTRA BINS TO FIT LOUVERED PANELS AND BENCH RACKS

MODEL NO.	QUS 200	QUS 210	QUS 220	QUS 221	QUS 224	QUS 230	QUS 233	QUS 234	QUS 235	QUS 239	QUS 240	QUS 241	QUS 242	QUS 245	QUS 250	QUS 255	QUS 260	QUS 265	QUS 270
QLP-1819	16	16	16	9	12	9	9	9	3	4	4	4	4	3	2	1	1	4	1
QLP-1861	60	60	60	30	30	30	30	30	15	14	14	14	14	10	7	7	5	12	5
QLP-2721	30	30	30	12	12	12	12	12	6	6	6	6	6	3	2	4	4	6	1
QLP-3612	18	18	18	12	12	12	12	12	6	4	4	4	4	4	2	6	3	8	2
QLP-3619	40	40	40	18	24	18	18	18	9	8	8	8	8	6	4	6	3	8	2
QLP-3661	120	120	120	60	80	60	60	60	30	28	28	28	28	20	14	21	15	24	10
QLP-4819	55	55	55	24	24	24	24	24	12	10	10	10	10	6	4	8	8	10	2
QLP-4861	165	165	165	80	80	80	80	80	40	35	35	35	35	20	14	28	20	30	10
QBR-1819	16	16	16	9	12	9	9	9	3	4	4	4	4	3	2	1	1	4	1
QBR-2721	30	30	30	12	12	12	12	12	6	6	6	6	6	3	2	4	4	6	1
QBR-3612	18	18	18	12	12	12	12	12	6	4	4	4	4	4	2	6	3	8	2
QBR-3619	32	32	32	18	32	18	18	18	9	8	8	8	8	6	4	6	3	8	2

See Page 13 for bin dimensions.

LOUVERED RACKS



QSS-3666H

Single Sided Louvered Rack

36"L x 12-1/2"W x 66"H

Single sided unit accepts all sizes of Ultra Bins (up to 120 bins) 800 lb. capacity. (Bins sold separately)



QDS-3666H

Double Sided Louvered Rack

36"L x 25"W x 66"H

Mobile unit accepts all sizes of Ultra Bins (up to 240 bins) 2,000 lb. capacity. (Bins sold separately)



QMD-36H

Mobile Double Sided Louvered Rack

36"L x 25"W x 72"H

Mobile unit accepts all sizes of Ultra Bins (up to 240 bins). Comes complete with four 5" hard rubber, heavy-duty casters, 2 swivel and 2 rigid. 1,200 lb. capacity. Easy to pull handle included. (Bins sold separately)



QSS-1866H

Single Sided Louvered Rack

18"L x 12-1/2"W x 66"H

Single sided unit accepts all sizes of Ultra Bins (up to 60 bins) 375 lb. capacity. (Bins sold separately)



new

Fastest
Shipping
IN THE INDUSTRY

LOWEST
PRICE
GUARANTEED!

Customize
your own unit!

1. Select the bench rack of your choice.
2. See page 13 and choose the bin that best fits your need.
3. Go to the chart at the bottom of this page and determine how many bins fit on the unit you selected.
4. Place your order for both unit and bins (Bins sold in carton quantities).

MODEL NO.	DIMENSIONS L" x W" x H"	CTN QTY	CTN WGT
Single Sided Unit, 375 lb. capacity			
QSS-1866H	18"L x 12-1/2"W x 66"H	1	40 lbs
Single Sided Unit, 800 lb. capacity			
QSS-3666H	36"L x 12-1/2"W x 66"H	1	60 lbs
Double Sided Unit, 2,000 lb. capacity			
QDS-3666H	36"L x 25"W x 66"H	1	106 lbs
Double Sided, Mobile Unit, 1,200 lb. capacity			
QMD-36H	36"L x 25"W x 72"H	1	155 lbs

QUANTITY OF ULTRA BINS TO FIT LOUVERED RACKS

MODEL NO.	QUS 200	QUS 210	QUS 220	QUS 221	QUS 224	QUS 230	QUS 233	QUS 234	QUS 235	QUS 239	QUS 240	QUS 241	QUS 242	QUS 245	QUS 250	QUS 255	QUS 260	QUS 265	QUS 270
QSS-1866H	60	60	60	30	30	30	30	30	15	14	14	14	12	10	7	7	5	12	5
QSS-3666H	120	120	120	60	80	60	60	60	30	28	28	28	24	20	14	21	15	24	10
QDS-3666H	240	240	240	120	160	120	120	120	60	56	56	56	48	40	28	42	30	48	20
QMD-36H	240	240	240	120	160	120	120	120	60	56	56	56	48	40	28	42	30	48	20

See Page 13 for bin dimensions.

HANGING RAIL SYSTEMS

Ultra Rail Systems

Rails may be mounted on any suitable surface including walls, benches, inside service trucks and cabinets or on carts. Fasten securely to assure proper load bearing. Configure Rail System to meet your custom requirements.
(Bins sold separately)



Customize your own unit!

1. Select the hanging unit of your choice.
2. Turn to **page 13** and choose the bin that best fits your need.
3. Go to the chart at the bottom of this page and determine how many bins fit on the unit you selected.
4. Place your order for both unit and bins
(Bins sold in carton quantities).



Hang-n-Stack Bins - Complete Packages

Comes with 2 handy 12" plastic rails ideal for mounting to any surface. Bins can hang or stack securely providing an efficient bin storage system. Available in Blue, Yellow, Red, Green, Ivory and Black. Rails available in White. Clear available see **page 5**.



QRU-1W - Steel Rail

48"L x 3"H. Steel Rail mounts to any surface or workbench and accepts 14 sizes of Ultra bins (up to 11 bins per rail). 125 lb. load capacity. (Bins sold separately)

MODEL NO.	DESCRIPTION	CTN QTY	CTN WGT
QRU-1W	48" Wall Rail	1	6 lbs

LOWEST PRICE GUARANTEED!

MODEL NO.	BIN DIMENSIONS L" x W" x H"	DESCRIPTION	CTN WGT
HNS200	5" x 4-1/8" x 3"	6 bins + 2 rails	2 lbs
HNS210	5-3/8" x 4-1/8" x 3"	6 bins + 2 rails	2 lbs
HNS220	7-3/8" x 4-1/8" x 3"	6 bins + 2 rails	3 lbs
HNS230	10-7/8" x 5-1/2" x 5"	4 bins + 2 rails	5 lbs
HNS006	Extra Rails	2 rails	1 lb



Shown here with 24 QUS240 bins.
(Bins sold separately)

QRU-12S

Single Sided Rack, 12 Rails

Accepts 12 sizes of Ultra bins (up to 96 bins)
600 lb. capacity. See chart for bin configurations.
(Bins sold separately)



Shown here with 192 QUS220 bins.
(Bins sold separately)

QRU-12D

Double Sided Rack, 12 Rails

36"L x 20"W x 53"H
Accepts 12 sizes of Ultra bins (up to 192 bins)
1,600 lb. capacity. See chart for bin configurations.
(Bins sold separately)



Shown here with 96 QUS230 bins.
(Bins sold separately)

QRU-16D + QRU-MOB

Double Sided Rack, 16 Rails with Mobile Kit

36"L x 20"W x 59"H
Accepts 7 sizes of Ultra bins (up to 96 bins)
1,000 lb. capacity. See chart for bin configurations.
(Bins sold separately)

QRU-16S

Single Sided Rack, 16 Rails

36"L x 15"W x 53"H
Accepts 7 sizes of Ultra bins (up to 48 bins)
600 lb. capacity. See chart for bin configurations.
(Bins sold separately)

QRU-16D

Double Sided Rack, 16 Rails

Accepts 7 sizes of Ultra bins (up to 96 bins)
1,600 lb. capacity. See chart for bin configurations.
(Bins sold separately)

QRU-12D + QRU-MOB

Double Sided Rack, 12 Rails with Mobile Kit

Accepts 12 sizes of Ultra bins (up to 192 bins)
1,000 lb. capacity. See chart for bin configurations.
(Bins sold separately)

QUANTITY OF ULTRA BINS TO FIT RAIL UNITS

MODEL NO.	DESCRIPTION	DIMENSIONS L" x W" x H"	QUS 200	QUS 210	QUS 220	QUS 221	QUS 224	QUS 230	QUS 233	QUS 234	QUS 235	QUS 239	QUS 240	QUS 241	QUS 242	QUS 245	QUS 250	QUS 255	QUS 260	QUS 265	QUS 270
QRU-1W	48"L Steel Rail	48" x - x 3"	11	11	11	8	11	8	8	8	4	5	5	5	5	3	-	-	-	-	-
QRU-12S	Rack, 1 sided 12 rail	36" x 15" x 53"	96	96	96	-	-	-	-	-	-	24	24	24	20	-	12	12	12	20	8
QRU-16S	Rack, 1 sided 16 rail	36" x 15" x 53"	-	-	-	48	48	48	48	48	24	-	-	-	-	16	-	-	-	-	-
QRU-12D	Rack, 2 sided 12 rail	36" x 20" x 53"	192	192	192	-	-	-	-	-	-	48	48	48	40	-	24	24	24	40	16
QRU-16D	Rack, 2 sided 16 rail	36" x 20" x 53"	-	-	-	96	96	96	96	96	48	-	-	-	-	32	-	-	-	-	-

QRU-MOB

Mobilizes Double Sided Units

See Page 13 for bin dimensions.

COMPLETE PACKAGE UNITS

Bench Racks - Complete Packages

Bench Racks: 36"L x 8"W x 19"H and 27"L x 8"W x 21"H. Both bench racks are available in 3 pre-configured choices. Bench racks can be joined together to form continuous systems. Bins are available in Blue, Yellow, Red, Green, Ivory and Black.



QBR-3619-210-32



Louvered Panel - Complete Packages

Louvered Panels: 18"L x 19"H, 36"L x 19"H, 36"L x 61"H and 48"L x 61"H. Each available in 3 configurations. Louvered Panels are available in Gray or Beige color. To order a Beige Louvered Panel add BG to the model number (i.e. QLP-1819BG-210-18). Bins are available in Blue, Yellow, Red, Green, Ivory and Black.



QLP-1819-220-16



Single & Double Sided Rail Units - Complete Packages

Single Sided Unit: 36"L x 15"W x 53"H. 250 lb. capacity. Available in 4 different configurations.
Double Sided Unit: 36"L x 20"W x 53"H. 500 lb. capacity. Available in 4 different configurations. Mobilize double sided unit with the addition of QRU-MOB. Bins are available in Blue, Yellow, Red, Green, Ivory and Black.

QRU-16S-220230240



COMPLETE PACKAGES with bins!

Mobile Double Sided Louvered Rack Unit - Complete Packages

36"L x 25"W x 72"H Mobile unit 1,200 lb. capacity. Bins available in Blue, Yellow, Red, Green, Ivory or Black.

QMD-36H-230240



MODEL NO.	NO. OF BINS	BIN DIMENSIONS L" x W" x H"	SHIP WGT
Bench Rack 27"L x 8"W x 21"H With Bins			
QBR-2721-210-24	24	5-3/8" x 4-1/8" x 3"	23 lbs
QBR-2721-220-24	24	7-3/8" x 4-1/8" x 3"	25 lbs
QBR-2721-230-12	12	10-7/8" x 5-1/2" x 5"	28 lbs
Bench Rack 36"L x 8"W x 19"H With Bins			
QBR-3619-210-32	32	5-3/8" x 4-1/8" x 3"	29 lbs
QBR-3619-220-32	32	7-3/8" x 4-1/8" x 3"	31 lbs
QBR-3619-230-18	18	10-7/8" x 5-1/2" x 5"	37 lbs

MODEL NO.	NO. OF BINS	BIN DIMENSIONS L" x W" x H"	SHIP WGT
Louvered Panel 18"L x 19"H With Bins			
QLP-1819-210-16	16	5-3/8" x 4-1/8" x 3"	11 lbs
QLP-1819-220-16	16	7-3/8" x 4-1/8" x 3"	12 lbs
QLP-1819-230-9	9	10-7/8" x 5-1/2" x 5"	16 lbs
Louvered Panel 36"L x 19"H With Bins			
QLP-3619-210-32	32	5-3/8" x 4-1/8" x 3"	22 lbs
QLP-3619-220-32	32	7-3/8" x 4-1/8" x 3"	24 lbs
QLP-3619-230-18	18	10-7/8" x 5-1/2" x 5"	30 lbs
Louvered Panel 36"L x 61"H With Bins			
QLP-3661-220-120	120	7-3/8" x 4-1/8" x 3"	80 lbs
QLP-3661-230-60	60	10-7/8" x 5-1/2" x 5"	90 lbs
QLP-3661-240-28	28	14-3/4" x 8-1/4" x 7"	96 lbs
Louvered Panel 48"L x 61"H With Bins			
QLP-4861-220-165	165	7-3/8" x 4-1/8" x 3"	115 lbs
QLP-4861-230-80	80	10-7/8" x 5-1/2" x 5"	127 lbs
QLP-4861-240-35	35	14-3/4" x 8-1/4" x 7"	130 lbs

MODEL NO.	NO. OF BINS	BIN DIMENSION L" x W" x H"	SHIP WGT
Single Sided Rail System 36"L x 15"W x 53"H With Bins			
QRU-12S-220-96	96	7-3/8" x 4-1/8" x 3"	82 lbs
QRU-16S-230-48	48	10-7/8" x 5-1/2" x 5"	108 lbs
QRU-12S-240-24	24	14-3/4" x 8-1/4" x 7"	102 lbs
	16	7-3/8" x 4-1/8" x 3"	
QRU-16S-220230240	18	10-7/8" x 5-1/2" x 5"	108 lbs
	12	14-3/4" x 8-1/4" x 7"	
Double Sided Rail System 36"L x 20"W x 53"H With Bins			
QRU-12D-220-192	192	7-3/8" x 4-1/8" x 3"	113 lbs
QRU-16D-230-96	96	10-7/8" x 5-1/2" x 5"	155 lbs
QRU-12D-240-48	48	14-3/4" x 8-1/4" x 7"	153 lbs
QRU-MOB	Mobilizes double sided units		25 lbs

MODEL NO.	NO. OF BINS	BIN DIMENSIONS L" x W" x H"	CTN WGT
QMD-36H-220	240	7-3/8" x 4-1/8" x 3"	174 lbs
QMD-36H-230	120	10-7/8" x 5-1/2" x 5"	212 lbs
QMD-36H-240	56	14-3/4" x 8-1/4" x 7"	208 lbs
QMD-36H-230240	72	10-7/8" x 5-1/2" x 5"	217 lbs
	24	14-3/4" x 8-1/4" x 7"	

NEW! 1900 SERIES STACKING SHELF BINS



QNS348
Shown with included
Cross Divider



QNS358



QNS358CL



1900 Series Stacking Shelf Bins

Quantum's strong, durable polypropylene stacking shelf bins are ideal for large, heavy and bulky item storage. One cross divider is included per bin. Available in Blue, Ivory, Yellow and Clear.

MODEL NO.	OUTSIDE DIMENSIONS L" x W" x H"	INSIDE DIMENSIONS L" x W" x H"	CTN QTY	CTN WGT	DIVIDER	CTN QTY
QNS348	20-1/2" x 8-1/4" x 7"	20" x 7-3/8" x 6-1/2"	6	20	DNS348	6
QNS358	20-1/2" x 11" x 7"	20" x 10-1/8" x 6-1/2"	6	27	DNS358	6
NEW! Clear-View Stacking Shelf Bins						
QNS348CL	20-1/2" x 8-1/4" x 7"	20" x 7-3/8" x 6-1/2"	6	20	DNS348	6
QNS358CL	20-1/2" x 11" x 7"	20" x 10-1/8" x 6-1/2"	6	27	DNS358	6

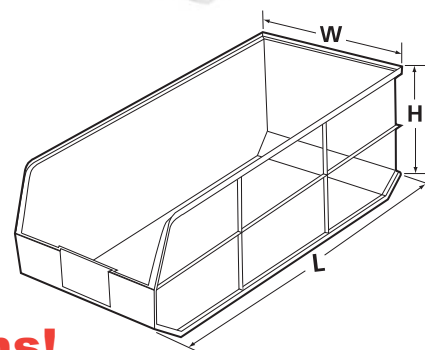

COMPLETE PACKAGES with bins!



WR8-348
21"W x 36"L x 74"H
8 shelves and 28 QNS348
20-1/2"L x 8-1/4"W x 7"H bins



WR8-348358
21"W x 36"L x 74"H
8 shelves and 12 QNS348 20-1/2"L x 8-1/4"W x 7"H bins
and 12 QNS358 20-1/2"L x 11"W x 7"H bins



WR8-358
21"W x 36"L x 74"H
8 shelves and 21 QNS358
20-1/2"L x 11"W x 7"H bins

GIANT OPEN HOPPER STORAGE UNITS

Storage Units - Complete Packages

These economical high density bin storage systems include heavy-duty giant stack bins with open hopper fronts for easy access. Optional clear windows maximize capacity, prevent spillage and convert the bin to a true tote. Optional dividers keep contents organized -- available on page 13. Heavy-duty, high grade shelving with 400 lb. capacity per shelf. Bins available in Blue, Yellow, Red, Green, Ivory and Black.

Fastest
Shipping
IN THE INDUSTRY

**LOWEST
PRICE
GUARANTEED!**

12" Deep Units 12"D x 36"W x 75"H Shelving



QSBU-230240

10 shelves and 36 QUS230
10-7/8"L x 5-1/2"W x 5"H bins
and 12 QUS240
14-3/4"L x 8-1/4"W x 7"H bins



QSBU-239

8 shelves and 28 QUS239
10-3/4"L x 8-1/4"W x 7"H bins



QSBU-240

8 shelves and 28 QU240
14-3/4"L x 8-1/4"W x 7"H bins



QSBU-250

8 shelves and 14 QUS250
14-3/4"L x 16-1/2"W x 7"H bins

COMPLETE PACKAGES with bins!

CLEAR BINS
VIEW
new Available on page 5

18" Deep Units 18"D x 36"W x 75"H Shelving



QSBU-255

8 shelves and 21 QUS255
16"L x 11"W x 8"H bins
(Windows sold separately)



QSBU-260

6 shelves and 15 QUS260
18"L x 11"W x 10"H bins
(Windows and dividers sold separately)



QSBU-265

7 shelves and 24 QUS265
18"L x 8-1/4"W x 9"H bins



QSBU-270

6 shelves and 10 QUS270
18"L x 16-1/2"W x 11"H bins

GIANT OPEN HOPPER WIRE SHELVING SYSTEMS



COMPLETE PACKAGES with bins!

12" & 14" Units



WR10-230240

14"W x 36"L x 74"H
10 shelves and 36 QUS230
10-7/8"L x 5-1/2"W x 5"H bins
and 12 QUS240
14-3/4"L x 8-1/4"W x 7"H bins



WR8-239

12"W x 36"L x 74"H
8 shelves and 28 QUS239
10-3/4"L x 8-1/4"W x 7"H bins



WR8-240

14"W x 36"L x 74"H
8 shelves and 28 QU240
14-3/4"L x 8-1/4"W x 7"H bins



WR8-250

14"W x 36"L x 74"H
8 shelves and 14 QUS250
14-3/4"L x 16-1/2"W x 7"H bins

MOBILIZE YOUR WIRE SHELVING



DB - Donut Bumper

Non-marking donut bumper used to protect walls and help cushion impact.

WR-00H (Mobile Kit)*

Set of four swivel polyurethane 5" x 1-1/4" casters, two with brakes. Can be used with all units shown. 1,200 lb. load capacity.

*Mobile kits recommended only for shelves 18" and wider

Fastest
Shipping
IN THE INDUSTRY

LOWEST PRICE
GUARANTEED!

18" Units

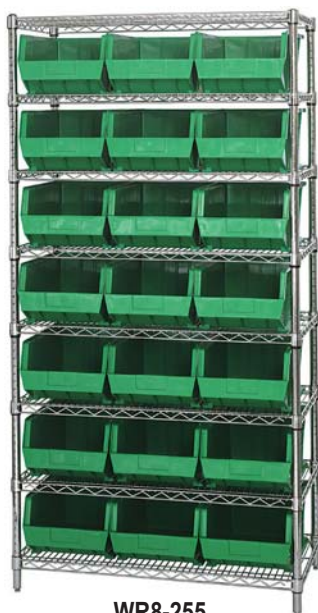

WR8-255

18"W x 36"L x 74"H
8 shelves and 21 QUS255
16"L x 11"W x 8"H bins



WR6-260

18"W x 36"L x 74"H
6 shelves and 15 QUS260
18"L x 11"W x 10"H bins



WR6-265

18"W x 36"L x 74"H
6 shelves and 20 QUS265
18"L x 8-1/4"W x 9"H bins



WR5-270

18"W x 36"L x 74"H
5 shelves and 8 QUS270
18"L x 16-1/2"W x 11"H bins

HULK 24" CONTAINERS

HULK 24" Containers

Organize and store your large and bulky items with these strong injection molded plastic, stackable containers. These extra large stacking containers offer a generous 2 feet in length to store your larger items. These huge stack bins are ideal for back to back use on 48" pallet rack or heavy-duty, extra deep shelving and are available in a variety of widths and heights. Heavy-duty front, back and side grips allow for easy handling. Optional clear plastic window increases bin capacity and provides a quick view of the bin contents. Optional dividers maximize flexibility and keep contents organized. Wide stacking ledge and anti-slide lock keep stacked bins steady and prevent forward shifting. Waterproof bins resist rust and corrosion. Bins are autoclavable up to 250°F and are resistant to extreme cold. Available in Blue, Red and Yellow. See page 6 to order clear bins.

24" HULK CONTAINERS available in 8 sizes and in 4 colors!



QUS950

LOWEST PRICE GUARANTEED!

CLEAR BINS VIEW
Available on page 6

Fastest Shipping
IN THE INDUSTRY



QUS952

QUS951

QUS954

QUS955

QUS953

QUS950

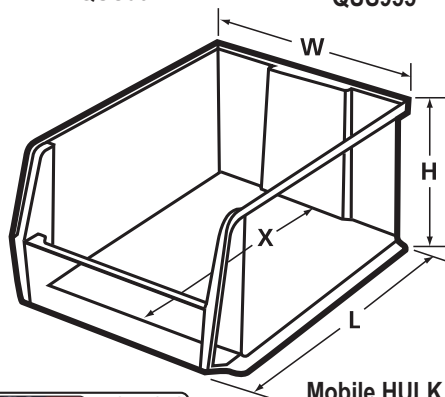

Mobile HULK Container

- Ideal for transport of heavy and bulky parts
- Bin comes with 4 swivel, 3" casters, all with brakes, allowing up to 250 lb. mobile load capacity

QUS965MOB

QUS953
Shown with Optional Divider and Window

MODEL NO.	OUTSIDE DIMENSIONS L" x W" x H"	INSIDE DIMENSIONS L" x W" x H"	X"	CTN QTY	CTN WGT	CLEAR WINDOW	CTN QTY	DIVIDER	CTN QTY
QUS950	23-7/8" x 8-1/4" x 7"	21-7/8" x 6-1/4" x 6-5/8"	19"	6	18 lbs	WUS950/970	6	DUS950	6
QUS951	23-7/8" x 8-1/4" x 9"	21-7/8" x 6-1/4" x 8-3/4"	18-3/4"	6	21 lbs	WUS951	6	DUS951	6
QUS952	23-7/8" x 11" x 7"	21-7/8" x 9" x 6-7/8"	19"	4	14 lbs	WUS952	4	DUS952	6
QUS953	23-7/8" x 11" x 10"	21-1/2" x 8-7/8" x 9-3/4"	18-3/4"	4	18 lbs	WUS953/973	4	DUS953	6
QUS954	23-7/8" x 16-1/2" x 11"	21-7/8" x 14-1/4" x 10-3/4"	18-3/4"	1	7 lbs	WUS954/974	1	DUS954	6
QUS964MOB	23-7/8" x 16-1/2" x 11"	21-7/8" x 14-1/4" x 10-3/4"	18-3/4"	1	9 lbs	WUS954/974	1	DUS954	6
QUS955	23-7/8" x 18-1/4" x 12"	21-1/2" x 16" x 11-3/4"	17-3/4"	1	8 lbs	WUS955/975	1	DUS955	6
QUS965MOB	23-7/8" x 18-1/4" x 12"	21-1/2" x 16" x 11-3/4"	17-3/4"	1	10 lbs	WUS955/975	1	DUS955	6

* With casters, overall height for mobile container will be increased by 3"

HULK SHELVING SYSTEMS - COMPLETE PACKAGES



2475-950

24"D x 36"W x 75"H
8 shelves and 28 QUS950
23-7/8"L x 8-1/4"W x 7"H bins



2475-951

24"D x 36"W x 75"H
7 shelves and 24 QUS951
23-7/8"L x 8-1/4"W x 9"H bins



2475-952

24"D x 36"W x 75"H
8 shelves and 21 QUS952
23-7/8"L x 11"W x 7"H bins



2475-953

24"D x 36"W x 75"H
6 shelves and 15 QUS953
23-7/8"L x 11"W x 10"H bins



2475-954

24"D x 36"W x 75"H
6 shelves and 10 QUS954
23-7/8"L x 16-1/2"W x 11"H bins



2475-950952

24"D x 36"W x 75"H
8 shelves and 12 QUS950
23-7/8"L x 8-1/4"W x 7"H bins
and 12 QUS952
23-7/8"L x 11"W x 7"H bins



2475-953954

24"D x 36"W x 75"H
8 shelves and 9 QUS953
23-7/8"L x 11"W x 10"H bins
and 4 QUS954
23-7/8"L x 16-1/2"W x 11"H bins



2475-20-MIX

24"D x 36"W x 75"H
7 shelves and 8 QUS950
23-7/8"L x 8-1/4"W x 7"H bins
and 3 QUS952
23-7/8"L x 11"W x 7"H bins
and 4 QUS951
23-7/8"L x 8-1/4"W x 9"H bins
and 3 QUS953
23-7/8"L x 11"W x 10"H bins
and 2 QUS954 bins
23-7/8"L x 16-1/2"W x 11"H bins



COMPLETE WITH
HULK
24" CONTAINERS

CLEAR BINS
VIEW
new Available on page 6

Fastest
Shipping
IN THE INDUSTRY

LOWEST
PRICE
GUARANTEED!

HULK SHELVING SYSTEMS - COMPLETE PACKAGES



WR8-950

24"W x 36"L x 74"H
8 shelves and 28 QUS950
23-7/8"L x 8-1/4"W x 7"H bins



WR7-951

24"W x 36"L x 74"H
7 shelves and 24 QUS951
23-7/8"L x 8-1/4"W x 9"H bins



WR8-952

24"W x 36"L x 74"H
8 shelves and 21 QUS952
23-7/8"L x 11"W x 7"H bins



WR6-953

24"W x 36"L x 74"H
6 shelves and 15 QUS953
23-7/8"L x 11"W x 10"H bins



WR6-954

24"W x 36"L x 74"H
6 shelves and 10 QUS954
23-7/8"L x 16-1/2"W x 11"H bins



WR5-955

24"W x 42"L x 74"H
5 shelves and 8 QUS955
23-7/8"L x 18-1/4"W x 12"H bins



WR8-950952

24"W x 36"L x 74"H
8 shelves and 12 QUS950
23-7/8"L x 8-1/4"W x 7"H bins
and 12 QUS952
23-7/8"L x 11"W x 7"H bins



WR7-20-MIX

24"W x 36"L x 74"H
7 shelves and 8 QUS950
23-7/8"L x 8-1/4"W x 7"H bins
and 3 QUS952
23-7/8"L x 11"W x 7"H bins
and 4 QUS951
23-7/8"L x 8-1/4"W x 9"H bins
and 3 QUS953
23-7/8"L x 11"W x 10"H bins
and 2 QUS954 bins
23-7/8"L x 16-1/2"W x 11"H bins

MOBILIZE YOUR WIRE SHELVING



DB - Donut Bumper

Non-marking donut bumper used to protect walls and help cushion impact.

WR-00H (Mobile Kit)*

Set of four swivel polyurethane 5" x 1-1/4" casters, two with brakes. Can be used with all units shown. 1,200 lb. load capacity.

*Mobile kits recommended only for shelves 18" and wider

Fastest
Shipping
IN THE INDUSTRY

LOWEST PRICE
GUARANTEED!

CLEAR VIEW
new Available on page 6

800 lb.
Capacity per shelf

HULK 30" & 36" CONTAINERS



QUS974



QUS976

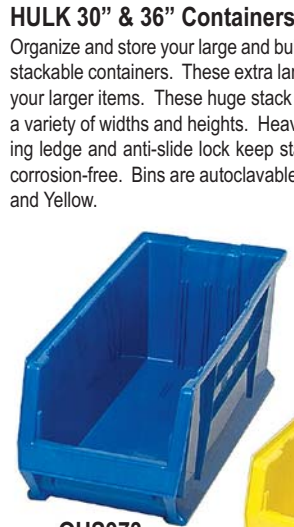

QUS973

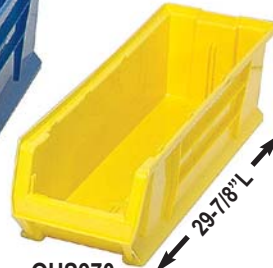

QUS970

Optional clear plastic window increases bin capacity and provides a quick view of the bin contents.

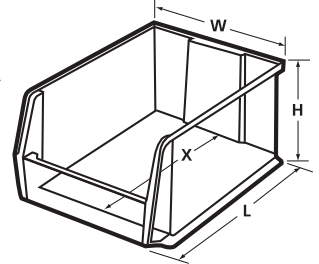

QUS975

HULK 30" CONTAINERS

MODEL NO.	OUTSIDE DIMENSIONS L" x W" x H"	INSIDE DIMENSIONS L" x W" x H"	X"	CTN QTY	CTN WGT	CLEAR WINDOW	CTN QTY	DIVIDER	CTN QTY
QUS970	29-7/8" x 8-1/4" x 7"	27-7/8" x 6-1/4" x 6-3/4"	25"	6	23 lbs	WUS950/970	6	DUS970	6
QUS973	29-7/8" x 11" x 10"	27-7/8" x 8-7/8" x 9-5/8"	24-3/4"	4	22 lbs	WUS953/973	4	DUS973	4
QUS974	29-7/8" x 16-1/2" x 11"	27-5/8" x 14-1/4" x 10-5/8"	24-3/4"	1	8 lbs	WUS954/974	1	DUS974	1
QUS984MOB	29-7/8" x 16-1/2" x 11"	27-5/8" x 14-1/4" x 10-5/8"	24-3/4"	1	10 lbs	WUS954/974	1	DUS974	1
QUS975	29-7/8" x 18-1/4" x 12"	27-1/2" x 16" x 11-3/4"	23-3/4"	1	9 lbs	WUS955/975	1	DUS975	1
QUS985MOB	29-7/8" x 18-1/4" x 12"	27-1/2" x 16" x 11-3/4"	23-3/4"	1	11 lbs	WUS955/975	1	DUS975	1
QUS976	29-7/8" x 16-1/2" x 15"	27-3/8" x 14" x 14-3/4"	23-1/2"	1	10 lbs	WUS976	1	DUS976	1
QUS986MOB	29-7/8" x 16-1/2" x 15"	27-3/8" x 14" x 14-3/4"	23-1/2"	1	12 lbs	WUS976	1	DUS976	1

* With casters, overall height for mobile container will be increased by 3"



We've got **BIG ONES!**

LOWEST PRICE GUARANTEED!



HULK 36" CONTAINERS

MODEL NO.	OUTSIDE DIMENSIONS L" x W" x H"	INSIDE DIMENSIONS L" x W" x H"	X"	CTN QTY	CTN WGT	DIVIDER	CTN QTY
QUS993	35-7/8" x 16-1/2" x 17-1/2"	33-1/8" x 14" x 17-1/4"	28-1/4"	1	14 lbs	DUS993	1
QUS994MOB	35-7/8" x 16-1/2" x 17-1/2"	33-1/8" x 14" x 17-1/4"	28-1/4"	1	17 lbs	DUS993	1
QUS995	35-7/8" x 19-7/8" x 17-1/2"	33-1/8" x 17-3/8" x 17-1/4"	28-1/4"	1	15 lbs	DUS995	1
QUS996MOB	35-7/8" x 19-7/8" x 17-1/2"	33-1/8" x 17-3/8" x 17-1/4"	28-1/4"	1	17 lbs	DUS995	1
QUS997	35-7/8" x 23-7/8" x 17-1/2"	33-1/4" x 21-3/8" x 17-1/4"	28-1/4"	1	18 lbs	DUS997	1
QUS998MOB	35-7/8" x 23-7/8" x 17-1/2"	33-1/4" x 21-3/8" x 17-1/4"	28-1/4"	1	20 lbs	DUS997	1

* With casters, overall height for mobile container will be increased by 3"

SIZE does matter...



HULK 30" WIRE - COMPLETE PACKAGES



WR8-970

30"W x 36"L x 74"H
8 shelves and 28 QUS970
29-7/8"L x 8-1/4"W x 7"H bins



WR6-973

30"W x 36"L x 74"H
6 shelves and 15 QUS973
29-7/8"L x 11"W x 10"H bins



WR6-974

30"W x 36"L x 74"H
6 shelves and 10 QUS974
29-7/8"L x 16-1/2"W x 11"H bins



WR6-973974

30"W x 36"L x 74"H
6 shelves and 9 QUS973
29-7/8"L x 11"W x 10"H bins
and 4 QUS974
29-7/8"L x 16-1/2"W x 11"H bins

QUANTUM CHROME WIRE SHELVING UNITS

Complete With Bins



700 lb.
Capacity per shelf

COMPLETE WITH
HULK
CONTAINERS



WR5-975

30"W x 42"L x 74"H
5 shelves and 8 QUS975
29-7/8"L x 18-1/4"W x 12"H bins

**MOBILIZE
YOUR WIRE
SHELVING**



DB - Donut Bumper

Non-marking donut bumper used to protect walls and help cushion impact.

WR-00H (Mobile Kit)*

Set of four swivel polyurethane 5" x 1-1/4" casters, two with brakes. Can be used with all units shown. 1,200 lb. load capacity.

*Mobile kits recommended only for shelves 18" and wider

Fastest
Shipping
IN THE INDUSTRY

**LOWEST
PRICE
GUARANTEED!**

HULK 36" WIRE - COMPLETE PACKAGES



WR5-993

36"W x 36"L x 86"H
5 shelves and 8 QUS993
35-7/8"L x 16-1/2"W x 17-1/2"H bins



WR5-995

36"W x 48"L x 86"H
5 shelves and 8 QUS995
35-7/8"L x 19-7/8"W x 17-1/2"H bins



WR5-997

36"W x 60"L x 86"H
5 shelves and 8 QUS997
35-7/8"L x 23-7/8"W x 17-1/2"H bins



Complete Packages with
36" HULK
Containers

Fastest
Shipping
IN THE INDUSTRY

LOWEST PRICE
GUARANTEED!

QUANTUM CHROME WIRE SHELVING with HULK 36" Containers COMPLETE PACKAGES!

SIZE
does matter...

600 lb.
Capacity per shelf

MOBILIZE YOUR WIRE SHELVING



DB - Donut Bumper

Non-marking donut bumper used to protect walls and help cushion impact.

WR-00H (Mobile Kit)*

Set of four swivel polyurethane 5" x 1-1/4" casters, two with brakes. Can be used with all units shown. 1,200 lb. load capacity.

*Mobile kits recommended only for shelves 18" and wider

NEW! RACK BIN CONTAINERS

RACKBIN™

42"

**THE FIRST & ONLY BIN
DESIGNED SPECIFICALLY
TO FIT PALLET RACK**



- These extra large bins offer a generous 42" (3-1/2 Feet) in length to store your larger items
- 42" length ensures no wasted space on 42" deep rack
- Heavy-duty front, back and side grips allow for easy handling
- Wide stacking ledge and anti-slide lock keep stack bins steady and prevent forward shifting
- Have eight 1/4" drill hole pattern on bottom of bin for easy hole insertion for drainage and air circulation if needed
- Waterproof bins are corrosion free
- Available in Blue and Gray



new



MODEL NO.	OUTSIDE DIMENSIONS L" x W" x H"	INSIDE DIMENSIONS L" x W" x H"	X	CTN QTY	CTN WGT
QRB166	41-7/8" x 16-1/2" x 17-1/2"	40-1/8" x 14" x 16-1/2"	35"	1	16 lbs
QRB176MOB	41-7/8" x 16-1/2" x 17-1/2"	40-1/8" x 14" x 16-1/2"	35"	1	18 lbs
QRB206	41-7/8" x 19-7/8" x 17-1/2"	40-1/8" x 17-3/8" x 16-1/2"	35"	1	17 lbs
QRB216MOB	41-7/8" x 19-7/8" x 17-1/2"	40-1/8" x 17-3/8" x 16-1/2"	35"	1	19 lbs
QRB246	41-7/8" x 23-7/8" x 17-1/2"	40-1/8" x 21-1/2" x 16-1/2"	35"	1	19 lbs
QRB256MOB	41-7/8" x 23-7/8" x 17-1/2"	40-1/8" x 21-1/2" x 16-1/2"	35"	1	21 lbs

* With casters, overall height for mobile container will be increased by 3"

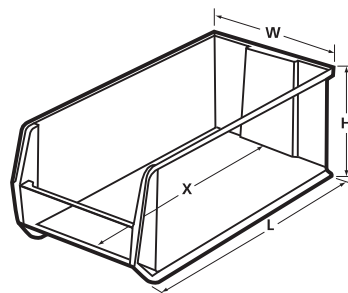

Fastest
Shipping
IN THE INDUSTRY

**LOWEST
PRICE
GUARANTEED!**

NEW! RACK BIN CONTAINERS WIRE PACKAGES



WRA86-2142C-206



WRA86-2136C-166

new



COMPLETE PACKAGES
with bins!

**LOWEST
PRICE
GUARANTEED!**

MODEL NO.	DIMENSIONS W" x L" x H"	NO. OF CONTAINERS	CONTAINER SIZE L" x W" x H"	SHIP WGT
WRA86-2136C-166	42" x 36" x 86"	8 QRB166	41-7/8" x 16-1/2" x 17-1/2"	272 lbs
WRA86-2142C-206	42" x 42" x 86"	8 QRB206	41-7/8" x 19-7/8" x 17-1/2"	290 lbs
WRA86-2148C-246	42" x 48" x 86"	8 QRB246	41-7/8" x 23-7/8" x 17-1/2"	326 lbs
WRA86-2154C-166	42" x 54" x 86"	12 QRB166	41-7/8" x 16-1/2" x 17-1/2"	386 lbs
WRA86-2172C-246	42" x 72" x 86"	12 QRB246	41-7/8" x 23-7/8" x 17-1/2"	502 lbs

GIANT STACK CONTAINERS



Giant Stack Containers

Multipurpose, wide open hopper front provides easy access for large part storage. Ideal for multiple applications in recycling, storing parts, tools and warehouse items. This bin will stack up to 6 bins high creating a sturdy, tall storage system. Injection molded from high density polyethylene, easy to clean, resists rust and corrosion and impervious to most chemicals. Large label holder allows for quick identification. Optional clear window increases storage capacity and allows for inspection of parts. Six 1/4" drill hole pattern on bottom of bin allows for easy hole insertion for drainage. QGH700 is available in Gray, Blue, Red, Ivory and Black. QGH600 and QGH800 are available in Gray, Blue and Red.



QGH700CL



QGH600



QGH700



QGH800

Curved lip and corners provide added strength

Ribs on side of bin provide added stability when stacked

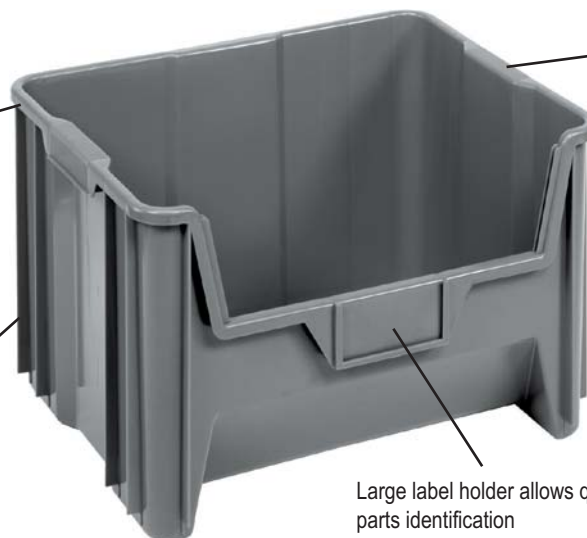

Large grip side handles

Large label holder allows quick parts identification



Fastest
Shipping
IN THE INDUSTRY



MODEL NO.	OUTSIDE DIMENSIONS L" x W" x H"	INSIDE DIMENSIONS L" x W" x H"	X"	CAP CU FT	CTN QTY	CTN WGT	WINDOW	CTN QTY
QGH600	17-1/2" x 10-7/8" x 12-1/2"	15-5/8" x 8" x 12-1/4"	13-1/2"	0.98	4	12	WGH600	4
QGH700*	15-1/4" x 19-7/8" x 12-7/16"	13-5/8" x 17-1/2" x 12-1/4"	11-1/2"	1.7	3	13	WGH700	3
QGH800	17-1/2" x 16-1/2" x 12-1/2"	15-5/8" x 13-3/4" x 12-1/4"	13-1/2"	1.6	2	8	WGH800	2

* Optional label for QGH700 is available, LGH700 (3 per package)



QGH705MOB



QGH805MOB

**LOWEST
PRICE
GUARANTEED!**

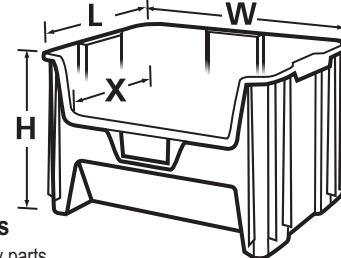

Mobile Giant Stack Containers

- Ideal for transport of heavy and bulky parts
- Container comes with 4 swivel, 3" casters, all with brakes, allowing for up to 250 lb. mobile load capacity
- Containers can stack with casters in place
- QGH705MOB is available in Gray, Blue, Ivory, Black or Red
- QGH805MOB is available in Gray, Blue and Red

MODEL NO.	OUTSIDE DIMENSIONS L" x W" x H"	INSIDE DIMENSIONS L" x W" x H"	X"	CAP CU FT	CTN QTY	CTN WGT	WINDOW	CTN QTY
QGH705MOB	15-1/4" x 19-7/8" x 12-7/16"*	13-5/8" x 17-1/2" x 12-1/4"	11-1/2"	1.7	3	22	WGH700	3
QGH805MOB	17-1/2" x 16-1/2" x 12-1/2"*	15-5/8" x 13-3/4" x 12-1/4"	13-1/2"	1.6	2	17	WGH800	2

* With casters, overall height for mobile container will be increased by 3"

GIANT STACK CONTAINER STORAGE CENTER

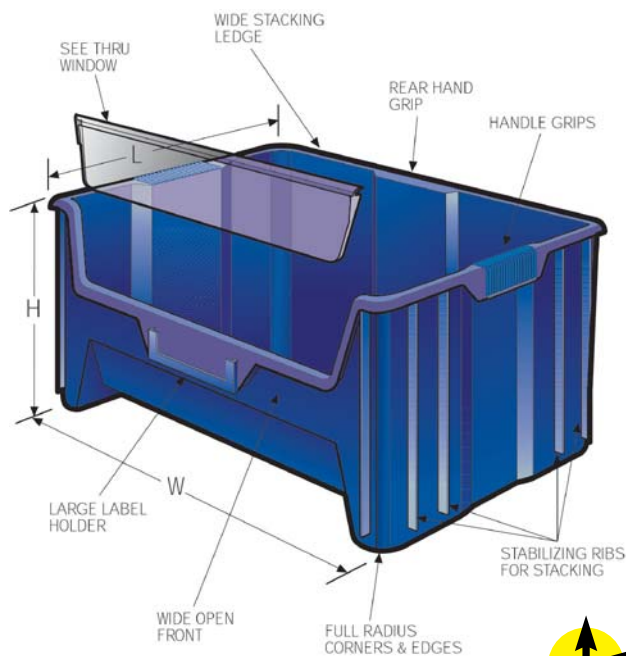

Bin Storage Center - Complete Packages

Organize, store and access your medium or large parts with this high capacity bin center. 475 lb. capacity per shelf and over 21 cubic feet of storage space. Smooth powder coat finish and cross bracing for increased stability. Easy assembly. QSBU-700 is available in Red, Gray, Blue, Ivory and Black. QSBU-600, QSBU-600800 and QSBU-800 are available in Gray, Blue and Red. Please specify color. One color per unit.



QSBU-700
18"D x 42"W x 75"H
6 shelves & 10 QGH700 bins

PERFORMANCE FEATURES AT A GLANCE:

- Extra thick side walls with reinforced rib designed for strength, allowing for 100 lb. stack capacity per bin
- Large grip side handles
- Stacks 6 bins high
- Six 1/4" drill hole pattern on bottom of bin allows for easy hole insertion for drainage

COMPLETE PACKAGES with bins!



QSBU-600
18"D x 36"W x 75"H
6 shelves & 15 QGH600 bins



QSBU-600800
18"D x 36"W x 75"H
6 shelves, 6 QGH600 bins and 6 QGH800 bins



QSBU-800
18"D x 36"W x 75"H
6 shelves & 10 QGH800 bins

GIANT STACK CONTAINER WIRE STORAGE CENTER



WR5-600

18"W x 36"L x 74"H, 5 shelves and 12 QGH600
17-1/2"L x 10-7/8"W x 12-1/2"H bins



WR5-600800

18"W x 36"L x 74"H, 5 shelves, 6 QGH600
17-1/2"L x 10-7/8"W x 12-1/2"H bins
and 4 QGH800
17-1/2"L x 16-1/2"W x 12-1/2"H bins



WR5-800

18"W x 36"L x 74"H, 5 shelves and 8 QGH800
17-1/2"L x 16-1/2"W x 12-1/2"H bins

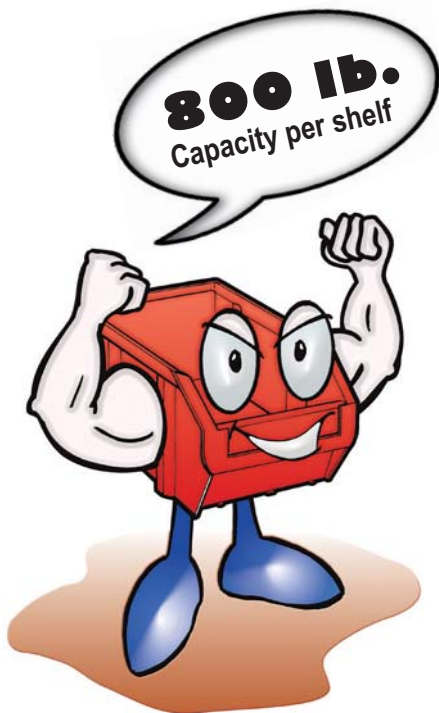

**COMPLETE
PACKAGES**
with bins!

MOBILIZE YOUR WIRE SHELVING



DB - Donut Bumper

Non-marking donut bumper used to protect walls and help cushion impact.

WR-00H (Mobile Kit)*

Set of four swivel polyurethane 5" x 1-1/4" casters, two with brakes. Can be used with all units shown. 1,200 lb. load capacity.

*Mobile kits recommended only for shelves 18" and wider



WR5-700

18"W x 42"L x 74"H, 5 shelves and 8 QGH700
15-1/4"L x 19-7/8"W x 12-7/16"H bins

Fastest
Shipping
IN THE INDUSTRY

CLEAR BINS
VIEW
new Available on page 9

**LOWEST
PRICE
GUARANTEED!**

GIANT OPEN HOPPER MAGNUM BINS

MAGNUM



MAGNUM Bins - The Toughest Bins in the Business

Heavy-duty, extra strong injection molded, high density polyethylene bins are ideal for transportation and storage of large and heavy parts. Open hopper front allows immediate access and visibility. Ribbed reinforced walls ensure extra strength. Double wall thickness with preformed lip allows bin to interlock and provides up to 150 lb. stack capacity. Transport these bins easily with rear molded handle. Molded in label slot. Impervious to most solvents, corrosion, rust and rot resistant. Resists temperatures from -40°F to 250°F. Optional window maximizes storage and prevents spillage. Available in Blue, Yellow, Green, Red and Black.

MODEL NO.	OUTSIDE DIMENSIONS L" x W" x H"	INSIDE DIMENSIONS L" x W" x H"	CTN QTY	CTN WGT	DIVIDERS	CTN QTY	WINDOWS	CTN QTY
QMS531	19-3/4" x 12-3/8" x 5-7/8"	17-3/4" x 11-1/4" x 5-1/8"	6	19 lbs	DMS531	6	WMS531	6
QMS532	19-3/4" x 12-3/8" x 7-7/8"	17-3/4" x 11-1/4" x 7-1/4"	6	23 lbs	DMS532	6	WMS532	6
QMS533	19-3/4" x 12-3/8" x 11-7/8"	17-3/4" x 11-1/4" x 11"	3	15 lbs	DMS533	3	WMS533	3
QMS543	19-3/4" x 18-3/8" x 11-7/8"	17-3/4" x 17-1/4" x 11"	1	8 lbs	DMS543	1	WMS543	1
QMS743*	29" x 18-3/8" x 11-7/8"	26-3/4" x 17-1/4" x 11"	1	10 lbs				
QMS843MOB*	29" x 18-3/8" x 14-7/8"	26-3/4" x 17-1/4" x 11"	1	14 lbs				

* Includes Heavy-Duty spread bar for extra strength and support.

**LOWEST
PRICE
GUARANTEED!**



PERFORMANCE FEATURES

AT A GLANCE:

- Available in 6 sizes and 5 colors (Blue, Yellow, Green, Red and Black) for inventory control and color code efficiency
- These heavy-duty containers are injection molded from high density polypropylene and are ideal for storage and transport of large parts
- Extra heavy, double wall thickness with interlock preformed lips allow containers to stack securely

**Fastest
Shipping**
IN THE INDUSTRY



Plastic Mobile Dolly

DLY-3018 Dolly with Padded Rubber Trim, available in Blue. 1,000 lb. capacity. Interior Dimensions 22-3/8"L x 16-3/4"W Exterior Dimensions 30"L x 18"W

Attached pull ring allows dolly to be pulled with ease

DLY-3018

(Bin sold separately)

MODEL NO.	DESCRIPTION	CTN WGT
DLY-3018	Dolly with Padded Rubber Trim	19 lbs
HANDLE-DLY	32" Dolly Pull Rod with Handle	2 lbs

Bins sold separately.

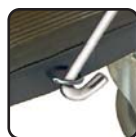

Mobile MAGNUM Bin

- Bin comes with 4 swivel 3" casters, all with brakes, allowing for 300 lb. mobile capacity
- Bins can stack on each other with casters in place



QMS743 and QMS843MOB

Includes heavy-duty spread bar for extra strength and support.

QMS843MOB

MAGNUM BIN UNITS COMPLETE PACKAGES

MAGNUM Bin Units - Complete Packages

These ultra heavy-duty shelving systems incorporate Quantum's Giant MAGNUM bins. Five combinations allow you a wide selection to choose from. Bins offer optional clear window fronts as well as dividers for maximum storage capacity. Shelving is tough 42" wide with a 350 lb. load capacity per shelf. Smooth powder coat finish which will not rust or corrode. Bins are available in Blue, Yellow, Green, Red and Black.

Toughest bins
MAGNUM Bins
in the business!

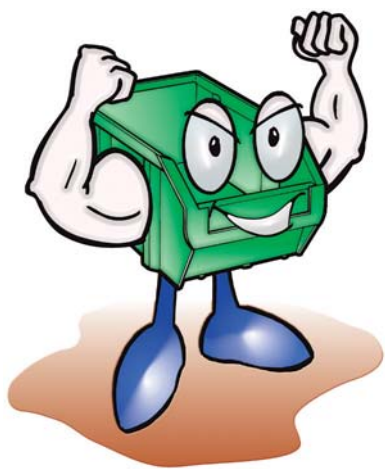

MSU-531

10 shelves and 27 QMS531
 19-3/4"L x 12-3/8"W x 5-7/8"H bins



MSU-16-MIX

7 shelves and
 4 QMS543 - 19-3/4"L x 18-3/8"W x 11-7/8"H bins,
 3 QMS533 - 19-3/4"L x 12-3/8"W x 11-7/8"H bins,
 6 QMS532 - 19-3/4"L x 12-3/8"W x 7-7/8"H bins,
 & 3 QMS531 - 19-3/4"L x 12-3/8"W x 5-7/8"H bins

**COMPLETE
 PACKAGES
 with bins!**



18" Deep Units 18"D x 42"W x 75"H Shelving

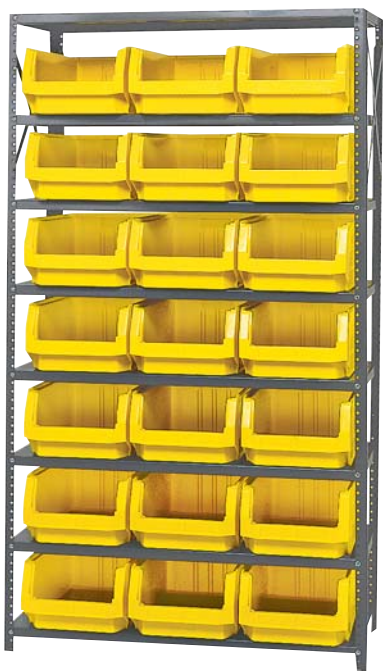

MSU-532

8 shelves and 21 QMS532
 19-3/4"L x 12-3/8"W x 7-7/8"H bins



MSU-533

6 shelves and 15 QMS533
 19-3/4"L x 12-3/8"W x 11-7/8"H bins



MSU-543

6 shelves and 10 QMS543
 19-3/4"L x 18-3/8"W x 11-7/8"H bins

MAGNUM BIN WIRE UNITS COMPLETE PACKAGES



WR9-531
18"W x 42"L x 74"H
9 shelves and 24 QMS531
19-3/4"L x 12-3/8"W x 5-7/8"H bins

MAGNUM

800 lb.
Capacity per shelf

MOBILIZE YOUR WIRE SHELVING



DB - Donut Bumper
Non-marking donut bumper used to protect walls and help cushion impact.

WR-00H (Mobile Kit)*
Set of four swivel polyurethane 5" x 1-1/4" casters, two with brakes. Can be used with all units shown. 1,200 lb. load capacity.
*Mobile kits recommended only for shelves 18" and wider



WR6-13-MIX
18"W x 42"L x 74"H, 6 shelves and
4 QMS543 - 19-3/4"L x 18-3/8"W x 11-7/8"H bins,
3 QMS533 - 19-3/4"L x 12-3/8"W x 11-7/8"H bins,
3 QMS532 - 19-3/4"L x 12-3/8"W x 7-7/8"H bins,
3 QMS531 - 19-3/4"L x 12-3/8"W x 5-7/8"H bins

**LOWEST
PRICE
GUARANTEED!**

COMPLETE PACKAGES with bins!

Fastest
Shipping
IN THE INDUSTRY



WR7-532
18"W x 42"L x 74"H
7 shelves and 18 QMS532
19-3/4"L x 12-3/8"W x 7-7/8"H bins



WR5-533
18"W x 42"L x 74"H
5 shelves and 12 QMS533
19-3/4"L x 12-3/8"W x 11-7/8"H bins



WR5-543
18"W x 42"L x 74"H
5 shelves and 8 QMS543
19-3/4"L x 18-3/8"W x 11-7/8"H bins

HEAVY-DUTY 36" WIDE ALL-WELDED BIN CABINETS

36" Wide All-Welded Bin Cabinets

All-Purpose cabinets provide secure storage for your valuable parts and tools. Standard performance features: ships completely assembled, ready to use, 14 gauge all-welded construction, gray baked-enamel finish which ensures years of heavy-duty service, 3 point locking handle supplied with 2 keys. To order a Beige cabinet, add BG right after cabinet prefix (i.e. **QSC-BG-36** or **MESH-BG-240** or **QPR-BG-101**). Bins are available in Blue, Yellow, Green, Red, Ivory, Black and Clear. See **page 13** for bin dimensions.



QSC-36

36"W x 24"D x 72"H. Total of 132 bins. Deep Door Model. Ship wt. 425 lbs.
48 QUS210, 48 QUS220, 18 QUS230, 12 QUS240 and 6 QUS250.



QSC-36S

36"W x 24"D x 72"H. Total of 102 bins. Deep Door Model. Ship wt. 465 lbs.
48 QUS210, 48 QUS220, 6 QUS250 and 3 adjustable shelves.

**COMPLETE
PACKAGES
with bins!**

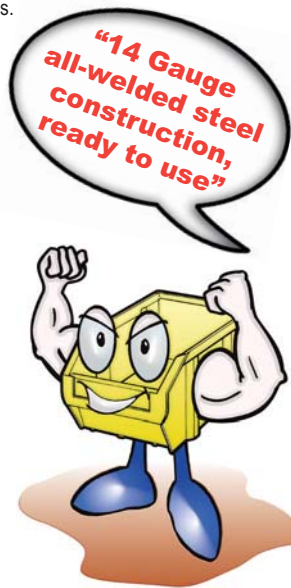

QSC-64-2S-6DS

36"W x 24"D x 72"H. Total of 64 bins. Deep Door Model. Ship wt. 427 lbs.
16 QUS240, 48 QUS220, 2 adjustable interior shelves and 6 door shelves.



QSC-36-96-4IS

36"W x 24"D x 72"H. Total of 96 bins. Deep Door Model. Ship wt. 377 lbs.
96 QUS210 and 4 adjustable interior shelves.

**ALL CABINETS
AVAILABLE IN
GRAY OR
BEIGE COLOR!**



QSC-36-FD

36"W x 18"D x 72"H. Total of 36 bins. Flush Door Model. Ship wt. 359 lbs.
18 QUS230, 12 QUS240 and 6 QUS250.



QSC-36-4IS-12DS

36"W x 24"D x 72"H. Deep Door Model. Ship wt. 308 lbs.
4 adjustable interior shelves and 12 adjustable door shelves.

HEAVY-DUTY 36" & 48" SPECIALTY BIN CABINETS



QPR-101 Sloped Shelf Pick Rack Flow Cabinet

36"W x 18"D x 78"H. Total of 72 bins.
Flush Door Model. Ship wt. 298 lbs.
Eight sloped shelves and one flat shelf hold
72 QSB101. Additional cabinet
configurations listed below. Bins available in
Blue, Red, Yellow, Green, Ivory, Black and
Clear.

MODEL NO.	NO. OF BINS	BIN MODEL	SHIP WGT
QPR-101	72	QSB101	298 lbs
QPR-102	45	QSB102	294 lbs
QPR-107	36	QSB107	289 lbs

See page 41 for bin dimensions

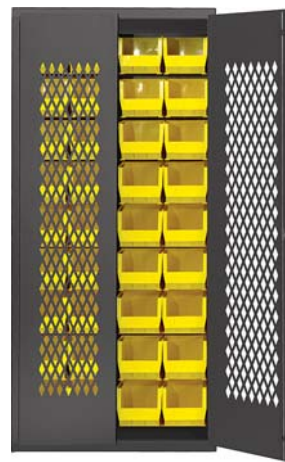

MESH-240 Wire Mesh Safe-View Bin Cabinet

36"W x 18"D x 78"H. Total of 36 bins.
Mesh Door Model. Ship wt. 290 lbs.
Louvered back wall fits 36 QUS240. Additional
cabinet configurations listed below.
Bins available in Blue, Red, Yellow,
Green, Ivory, Black and Clear.

MODEL NO.	NO. OF BINS	BIN MODEL	SHIP WGT
MESH-240	36	QUS240	290 lbs
MESH-240250	20 8	QUS240 QUS250	303 lbs
MESH-250	18	QUS250	288 lbs

See page 13 for bin dimensions.



QSC-C240250 Clear-View Security Bin Cabinet

36"W x 18"D x 78"H. Total of 28 bins.
Clear Door Model. Ship wt. 388 lbs.
Louvered back wall fits 20 QUS240 and 8
QUS250. Additional cabinet configurations
listed below. Bins available in Blue, Red,
Yellow, Green, Ivory, Black and Clear.

MODEL NO.	NO. OF BINS	BIN MODEL	SHIP WGT
QSC-C240	36	QUS240	390 lbs
QSC-C240250	20 8	QUS240 QUS250	388 lbs
QSC-C250	18	QUS250	392 lbs

See page 13 for bin dimensions.



QSC-3672-4D

36"W x 24"D x 72"H. Flush Door Model. Comes
complete with one 18" adjustable shelf, 12 door
shelves, four 31"W x 16"D drawers: two are 3" high,
one is 5" high, one is 6" high. Ship wt. 663.
Total of 58 removable bins:
36 QUS220, 18 QUS230 and 4 QUS240.
See page 13 for bin dimensions.

COMPLETE PACKAGES with bins!



QSC-QIC161

Interlocking Drawer Storage Cabinet

48"W x 24"D x 78"H. Total of 128 bins and 15 Interlocking Drawer
Cabinets. Ship wt. 507 lbs. Louvered door fits 128 QUS210 bins (see
page 13 for bin dimensions). Shelves hold 15 Interlocking Cabinet
Units. Interlocking Cabinets have a Gray exterior, Drawers are
available in Gray, Blue, Red and Ivory. Door bins available in
Blue, Red, Yellow, Green, Ivory, Black and Clear.

MODEL NO.	CABINET MODEL	NO. OF DRAWERS	SHIP WGT
QSC-QIC161	QIC-161	240	507 lbs
QSC-QIC122	QIC-122	180	507 lbs
QSC-QIC83	QIC-83	120	507 lbs
QSC-QIC64	QIC-64	90	507 lbs

See page 64 for cabinet and drawer dimensions.



QSC-36-MIN

36"W x 24"D x 36"H. Total of 66 bins. Ship wt. 218 lbs.
24 QUS210, 24 QUS220, 12 QUS230,
4 QUS240 and 2 QUS250.
See page 13 for bin dimensions.

HEAVY-DUTY 48" WIDE ALL-WELDED BIN CABINETS

48" Wide All-Welded Bin Cabinets

These 48" wide models offer all the features of the 36", but offer additional storage space. All cabinets are also available in Beige color. To order a Beige cabinet, add BG right after cabinet prefix (i.e. QSC-BG-36 or MESH-BG-240 or QPR-BG-101). Bins are available in Blue, Yellow, Green, Red, Ivory, Black and Clear. See page 13 for bin dimensions.

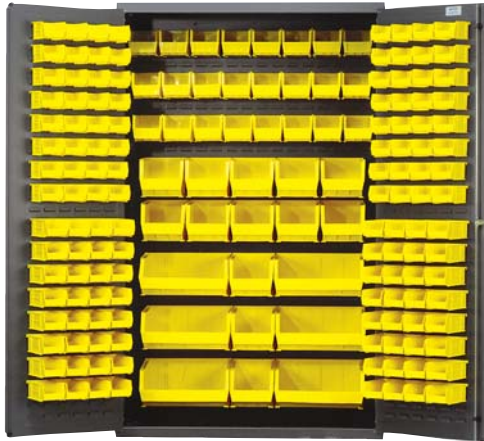

QSC-48

48"W x 24"D x 78"H. Total of 171 bins. Flush Door Model. Ship wt. 522 lbs.
64 QUS210, 64 QUS220, 24 QUS230, 13 QUS240 and 6 QUS250.

**COMPLETE
PACKAGES
with bins!**



QSC-48S

48"W x 24"D x 78"H. Total of 137 bins. Flush Door Model. Ship wt. 534 lbs.
64 QUS210, 64 QUS220, 3 QUS240, 6 QUS250 and 3 adjustable shelves.



QSC-4804

48"W x 24"D x 78"H. Total of 84 bins. Flush Door Model. Ship wt. 515 lbs.
20 QUS240, 64 QUS220, 2 adjustable interior shelves and 6 door shelves.



QSC-4803

48"W x 24"D x 78"H. Total of 128 bins. Flush Door Model. Ship wt. 505 lbs.
128 QUS210 and 4 adjustable interior shelves.



QSC-4805

48"W x 24"D x 78"H. Total of 64 bins. Flush Door Cabinet. Ship wt. 484 lbs. 64 QUS210 and punched panels on inside rear wall and doors.

new

**ALL CABINETS
AVAILABLE IN
GRAY OR
BEIGE COLOR!**



QSC-4IS-14DS

48"W x 24"D x 84"H. Deep Door Model. Ship wt. 572 lbs.
4 adjustable interior shelves and 14 adjustable door shelves.
800 lb. capacity per interior shelf. 60 lb. capacity per door shelf.

STORAGE CABINETS & RAIL CARTS

48" Wide All-Welded Bin Cabinet

This 48" wide models offer all the features of the 36", but offer additional storage space. Cabinets is also available in Beige color. To order a Beige cabinet, add BG right after cabinet prefix (i.e. QSC-3IS).

**ALL CABINETS
AVAILABLE IN
GRAY OR
BEIGE COLOR!**



QSC-3IS

48"W x 24"D x 78"H
Flush Door Model. Ship wt. 323 lbs.
3 adjustable shelves. 800 lb. capacity per shelf.



QSC-361878

48"W x 24"D x 78"H

new

Economy Industrial Cabinets

Quantum's new line of Economy Industrial Cabinets provide exceptional strength and security for storing all of your industrial parts and supplies. These fully assembled, 22 gauge steel cabinets feature shelves that handle up to 175 pounds each and are adjustable on 1" increments. Channel reinforced doors in 48" wide cabinets and boxed-formed shelves add additional strength and durability. Double doors swing open at 180 for full access ton full-length piano hinges, and include a 3-point locking recessed handle with keys. Available in Beige, Black or Gray.

MODEL NO.	DIMENSIONS W" x D" x H"	SHIP WGT
Cabinet with 2 Shelves		
QSC-361842	36" x 18" x 42"	75 lbs
Cabinet with 4 Shelves		
QSC-361872	36" x 18" x 72"	105 lbs
QSC-361878	36" x 18" x 78"	115 lbs
QSC-362472	36" x 24" x 72"	110 lbs
QSC-362478	36" x 24" x 78"	120 lbs
QSC-481878	48" x 18" x 78"	115 lbs
QSC-482478	48" x 24" x 78"	120 lbs



Economy Industrial Cabinets include a 3-point Locking recessed handle with keys



QSC-361842

48"W x 24"D x 78"H

Mobile Rail Carts

QUANTITY OF ULTRA BINS TO FIT RAIL UNITS

MODEL NO.	DESCRIPTION	QUANTITY OF ULTRA BINS TO FIT RAIL UNITS					
		QUS 200	QUS 210	QUS 220	QUS 230	QUS 235	QUS 239
QRC-4D	36" x 24" Rail Cart	64	64	64	48	24	16
QRC-7D	36" x 18" Rail Cart	96	96	96	-	-	-

See page 13 for bin dimensions.



QRC-4D Mobile Ergonomic Cart

36"L x 24"W x 35-1/2"H
Accepts 6 sizes of Ultra Bins (up to 64 bins).
800 lb. load capacity.
Bins available in Blue, Yellow, Green, Red, Ivory and Black. (Bins sold separately)



QRC-7D Mobile Ergonomic Cart

36"L x 18"W x 35-1/2"H
Accepts 3 sizes of Ultra Bins (up to 96 bins).
800 lb. load capacity.
Bins available in Blue, Yellow, Green, Red, Ivory and Black. (Bins sold separately)

HEAVY-DUTY 60" & 72" WIDE ALL-WELDED BIN CABINETS

Super-Wide Colossal Heavy-duty Cabinets

Super-wide, colossal cabinets available in 60" & 72" widths and 84" heights allowing for maximum and efficient storage while providing superior strength and security. Standard performance features: ships completely assembled, ready to use, 14 gauge all-welded construction, gray baked-enamel finish which ensures years of heavy-duty service, 3 point locking handle with provision for a pad-lock (**not included**) and 6" high legs make cabinets fork truck liftable. All cabinets are also available in Beige color. To order a Beige cabinet, add BG right after cabinet prefix (i.e. **QSC-BG-36** or **MESH-BG-240** or **QPR-BG-101**). Bins are available in Blue, Yellow, Green, Red, Ivory, Black and Clear. See **page 13** for bin dimensions.

**GRAY OR
BEIGE
COLOR!**

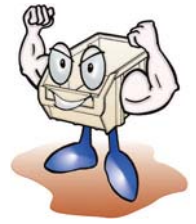

QSC-60

60"W x 24"D x 84"H. Total of 227 bins. Flush Door Model. Ship wt. 860 lbs.
80 QUS210, 90 QUS220, 30 QUS230, 18 QUS240 and 9 QUS250.



QSC-60S

60"W x 24"D x 84"H. Total of 185 bins. Flush Door Model. Ship wt. 878 lbs.
80 QUS210, 90 QUS220, 6 QUS240, 9 QUS250 and 3 adjustable shelves.



**PERFECT
WORK
HEIGHT!**

**COMPLETE
PACKAGES
with bins!**

QSC-60-BENCH

60"W x 30"D x 36"H Work Bench/Cabinet Combo. Total of 20 bins. Ship wt. 375 lbs.
20 QUS210, 1 shelf and 4 drawers. The working surface is covered by a 60"W x 30"D x 2"H maple top for rugged durability.

new



QSC-72

72"W x 24"D x 84"H. Total of 264 bins. Flush Door Model. Ship wt. 1,002 lbs.
96 QUS210, 96 QUS220, 36 QUS230, 24 QUS240 and 12 QUS250.



QSC-72S

72"W x 24"D x 84"H. Total of 212 bins. Flush Door Model. Ship wt. 955 lbs.
96 QUS210, 96 QUS220, 8 QUS240, 12 QUS250 and 3 adjustable shelves.

ECONOMY SHELF BINS

Economy Shelf Bins

Quantum's tough, durable, high density Shelf Bins are the industry standard for quality. These durable polypropylene bins feature a molded-in label holder, built-in rear hanglock which allows bins to tilt out for complete access when on shelving. A wide hopper front allows complete access to the contents of the bin. Edges are reinforced for added strength. They are designed for 12", 18" and 24" deep shelf units, racks or standard shelving. Bins are impervious to most chemicals. Available in Blue, Yellow, Red, Green, Ivory and Black. See page 7 to order Clear Bins.

**LOW COST! LONG LASTING!
UNBREAKABLE! REUSABLE!
4" HIGH BINS!**



QSB102CL



QSB101



QSB107



QSB109

Bin Cups

Bin cups have a raised, slotted label holder for easy parts identification. The entire bin cup may be removed for easy part retrieval. Available in 2 sizes and 2 colors: Blue and Yellow.

Dividers

Optional dividers fit snugly, horizontally across bins and are uniquely designed to allow for easy part labeling via individual label slots. All bins can accommodate up to 7 dividers.



Clear Label Holder

Clear Label Holders are available for Economy Shelf Bins & STORE-MORE Shelf Bins. Laser & Inkjet compatible inserts. Label holders fit all shelf bins (except QSB100). Package of 25. Model No.: LTR-0813

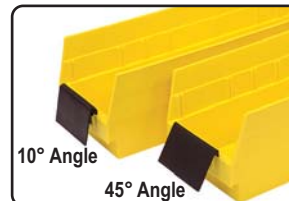

10° Angle
45° Angle

Extended Label Holders - simplify identification!

Optional extended label holders are designed for larger bar code scanning. Label holders fit all Shelf Bins (except QSB100).

MODEL NO.	OUTSIDE DIMENSIONS L" x W" x H"	CTN QTY	CTN WGT
QBC111	3-1/4" x 1-3/4" x 3"	48	4 lbs
QBC112	5-1/8" x 2-3/4" x 3"	48	7 lbs

MODEL NO.	DESCRIPTION	DIMENSIONS W" x H"	CTN QTY
ELH410	10° Angle	4" x 2-1/4"	24
ELH445	45° Angle	4" x 2-1/4"	24

MODEL NO.	OUTSIDE DIMENSIONS L" x W" x H"	INSIDE DIMENSIONS L" x W" x H"	CTN QTY	CTN WGT	DIVIDER	CTN QTY	NO. OF BIN CUPS PER BIN QBC111	QBC112
QSB100	11-5/8" x 2-3/4" x 4"	10-1/4" x 1-5/8" x 4"	36	13 lbs	-	-	3	0
QSB101	11-5/8" x 4-1/8" x 4"	10-1/4" x 3" x 4"	36	17 lbs	DSB101	50	6	2
QSB102	11-5/8" x 6-5/8" x 4"	10-1/4" x 5-1/2" x 4"	30	18 lbs	DSB102	50	9	4
QSB107	11-5/8" x 8-3/8" x 4"	10-1/4" x 7-1/8" x 4"	20	15 lbs	DSB107	50	12	4
QSB109	11-5/8" x 11-1/8" x 4"	10-1/4" x 10" x 4"	8	7 lbs	DSB109	50	18	6
QSB103	17-7/8" x 4-1/8" x 4"	16-1/2" x 3" x 4"	20	13 lbs	DSB103	50	9	3
QSB104	17-7/8" x 6-5/8" x 4"	16-1/2" x 5-1/2" x 4"	20	16 lbs	DSB104	50	15	6
QSB108	17-7/8" x 8-3/8" x 4"	16-1/2" x 7-1/8" x 4"	10	11 lbs	DSB108	50	19	6
QSB110	17-7/8" x 11-1/8" x 4"	16-1/2" x 10" x 4"	8	11 lbs	DSB110	50	29	8
QSB105	23-5/8" x 4-1/8" x 4"	22-1/8" x 3" x 4"	16	13 lbs	DSB105	50	13	4
QSB106	23-5/8" x 6-5/8" x 4"	22-1/8" x 5-1/2" x 4"	8	9 lbs	DSB106	50	21	8
QSB114	23-5/8" x 8-3/8" x 4"	22-1/8" x 7-1/8" x 4"	6	9 lbs	DSB114	50	24	8
QSB116	23-5/8" x 11-1/8" x 4"	22-1/8" x 10" x 4"	6	10 lbs	DSB116	50	35	16

Individual labels are available for all Shelf Bins. For label Model No. substitute "L" for "Q" in bin Model No. Ctn Qty: 50 Individual Labels

SHELF BIN SHELVING SYSTEMS

COMPLETE PACKAGES with bins!

Shelf Bin Systems - Complete Packages

Economical small parts storage systems keep parts easily accessible. Open hopper front bins with label area provide fast access to stored items. This all-in-one unit is easy to clean and will not rust or corrode. Heavy-duty, high grade shelving offers a 400 lb. capacity per shelf. 36" wide shelving has a smooth powder coat finish. Bins are available in Blue, Yellow, Red, Green, Ivory or Black.



1839-104



1275-102

**Economical
small parts
storage
systems
keep parts
easily
accessible!**



Rear "V" lock enables bins to be hung from shelf above when in use

**Units on this page
are also available
on Wire Shelving
see page 44**

MODEL NO.	NO. OF BINS	BIN SIZE L" x W" x H"	SHIP WGT
12" x 36" x 75" Unit, 13 Shelves			
1275-100	144 QSB100	11-5/8" x 2-3/4" x 4"	139 lbs
1275-101	96 QSB101	11-5/8" x 4-1/8" x 4"	117 lbs
1275-102	60 QSB102	11-5/8" x 6-5/8" x 4"	115 lbs
1275-107	48 QSB107	11-5/8" x 8-3/8" x 4"	120 lbs
1275-109	36 QSB109	11-5/8" x 11-1/8" x 4"	119 lbs
1275-000	Shelving Unit - No Bins		87 lbs
12" x 36" x 39" Unit, 7 Shelves			
1239-100	72 QSB100	11-5/8" x 2-3/4" x 4"	75 lbs
1239-101	48 QSB101	11-5/8" x 4-1/8" x 4"	67 lbs
1239-102	30 QSB102	11-5/8" x 6-5/8" x 4"	63 lbs
1239-107	24 QSB107	11-5/8" x 8-3/8" x 4"	64 lbs
1239-109	18 QSB109	11-5/8" x 11-1/8" x 4"	65 lbs
1239-000	Shelving Unit - No Bins		49 lbs
18" x 36" x 75" Unit, 13 Shelves			
1875-103	96 QSB103	17-7/8" x 4-1/8" x 4"	161 lbs
1875-104	60 QSB104	17-7/8" x 6-5/8" x 4"	155 lbs
1875-108	48 QSB108	17-7/8" x 8-3/8" x 4"	161 lbs
1875-110	36 QSB110	17-7/8" x 11-1/8" x 4"	158 lbs
1875-000	Shelving Unit - No Bins		113 lbs
18" x 36" x 39" Unit, 7 Shelves			
1839-103	48 QSB103	17-7/8" x 4-1/8" x 4"	87 lbs
1839-104	30 QSB104	17-7/8" x 6-5/8" x 4"	84 lbs
1839-108	24 QSB108	17-7/8" x 8-3/8" x 4"	87 lbs
1839-110	18 QSB110	17-7/8" x 11-1/8" x 4"	86 lbs
1839-000	Shelving Unit - No Bins		63 lbs

**Color code
products to
simplify
order
picking and
inventory
control!**

Fastest
Shipping
IN THE INDUSTRY

**LOWEST
PRICE
GUARANTEED!**



ECONOMY SHELF BINS SLOPED SHELVING UNITS

Shelf Bin Sloped Shelving Systems - Complete Packages

Pick Racks provide a convenient high density, easy access, sloped shelving system, available as bench units, single and double sided free standing and mobile units. Unit comes complete with Economical Shelf Bins. Sloped shelving unit keeps small and medium sized parts easily accessible. Open hopper front bins with label area, provide fast access to stored items. This all-in-one unit is easy to clean and will not rust or corrode. See chart for configurations. Bins are available in Blue, Yellow, Red, Green, Ivory or Black. One bin color per unit.



QPRHA-102
Bench Pick Rack
250 lb. capacity.



MODEL NO.	NO. OF BINS	BIN SIZE L" x W" x H"	SHIP WGT
BENCH RACKS 12" x 36" x 21" Unit, 3 Shelves			
QPRHA-100	36 QSB100	11-5/8" x 2-3/4" x 4"	41 lbs
QPRHA-101	24 QSB101	11-5/8" x 4-1/8" x 4"	38 lbs
QPRHA-102	15 QSB102	11-5/8" x 6-5/8" x 4"	36 lbs
QPRHA-107	12 QSB107	11-5/8" x 8-3/8" x 4"	36 lbs
QPRHA-109	9 QSB109	11-5/8" x 11-1/8" x 4"	37 lbs
QPRHA-000	BENCH RACK ONLY - NO BINS		
SINGLE SIDED RACKS 12" x 36" x 60" Unit, 8 Shelves			
QPRS-100	96 QSB100	11-5/8" x 2-3/4" x 4"	99 lbs
QPRS-101	64 QSB101	11-5/8" x 4-1/8" x 4"	85 lbs
QPRS-102	40 QSB102	11-5/8" x 6-5/8" x 4"	80 lbs
QPRS-107	32 QSB107	11-5/8" x 8-3/8" x 4"	81 lbs
QPRS-109	24 QSB109	11-5/8" x 11-1/8" x 4"	83 lbs
QPRS-000	RACK ONLY - NO BINS		
DOUBLE SIDED RACK 24" x 36" x 60" Unit, 16 Shelves			
QPRD-100	192 QSB100	11-5/8" x 2-3/4" x 4"	195 lbs
QPRD-101	128 QSB101	11-5/8" x 4-1/8" x 4"	169 lbs
QPRD-102	80 QSB102	11-5/8" x 6-5/8" x 4"	158 lbs
QPRD-107	64 QSB107	11-5/8" x 8-3/8" x 4"	160 lbs
QPRD-109	48 QSB109	11-5/8" x 11-1/8" x 4"	163 lbs
QPRD-000	RACK ONLY - NO BINS		
QDU-00	MOBILE KIT - Mobilizes all double sided units		

Twelve QSB100, eight QSB101, five QSB102, four QSB107, three QSB109, six QUS230, three QUS235, and two QUS245 fit across a standard 36" wide pick rack shelf.

SLOPED SHELVES! EASY ACCESS!
Most Popular & Versatile Storage Systems Sold!



QPRS-101
Single Sided Pick Rack
400 lb. capacity.



QPRD-107
Double Sided Pick Rack
800 lb. capacity.



QPRD-102 + QDU-00
Mobile, Double Sided Pick Rack
1,000 lb. capacity.

SHELF BIN WIRE SHELVING SYSTEMS



WR12-101

12"W x 36"L x 74"H
12 shelves and 77 QSB101
11-5/8"L x 4-1/8"W x 4"H bins



WR12-102

12"W x 36"L x 74"H
12 shelves and 55 QSB102
11-5/8"L x 6-5/8"W x 4"H bins



WR12-107

12"W x 36"L x 74"H
12 shelves and 44 QSB107
11-5/8"L x 8-3/8"W x 4"H bins



WR12-109

12"W x 36"L x 74"H
12 shelves and 33 QSB109
11-5/8"L x 11-1/8"W x 4"H bins

WR12-103

18"W x 36"L x 74"H
12 shelves and 77 QSB103
17-7/8"L x 4-1/8"W x 4"H bins

WR12-104

18"W x 36"L x 74"H
12 shelves and 55 QSB104
17-7/8"L x 6-5/8"W x 4"H bins

WR12-108

18"W x 36"L x 74"H
12 shelves and 44 QSB108
17-7/8"L x 8-3/8"W x 4"H bins

WR12-110

18"W x 36"L x 74"H
12 shelves and 33 QSB110
17-7/8"L x 11-1/8"W x 4"H bins

WR12-105

24"W x 36"L x 74"H
12 shelves and 77 QSB105
23-5/8"L x 4-1/8"W x 4"H bins

WR12-106

24"W x 36"L x 74"H
12 shelves and 55 QSB106
23-5/8"L x 6-5/8"W x 4"H bins

WR12-114

24"W x 36"L x 74"H
12 shelves and 44 QSB114
23-5/8"L x 8-3/8"W x 4"H bins

WR12-116

24"W x 36"L x 74"H
12 shelves and 33 QSB116
23-5/8"L x 11-1/8"W x 4"H bins



MOBILIZE YOUR WIRE SHELVING



DB - Donut Bumper

Non-marking donut bumper used to protect walls and help cushion impact.

WR-00H (Mobile Kit)*

Set of four swivel polyurethane 5" x 1-1/4" casters, two with brakes. Can be used with all units shown. 1,200 lb. load capacity.

*Mobile kits recommended only for shelves 18" and wider



WR6-36-1236-102
12"W x 36"L x 36"H



LOWEST PRICE GUARANTEED!

Complete Bin Center

Complete bin systems are available with 4 different size bins on a 12"W x 36"L x 36"H unit. This all-purpose bin center is an economical high density storage system that provides easy visibility to stored contents. Bins are available in Blue, Green, Ivory, Red, Yellow and Black. Please specify.

- Easy boltless assembly
- Wire allows air to circulate as well as provides ideal product visibility
- Durable chrome finish ensures years of heavy-duty dependability and service

MODEL NO.	NO. OF BINS	BIN SIZE L" x W" x H"	SHIP WGT
12" x 36" x 36" Unit, 6 Shelves			
WR6-36-1236-101	40 QSB101	11-5/8" x 4-1/8" x 4"	63 lbs
WR6-36-1236-102	25 QSB102	11-5/8" x 6-5/8" x 4"	50 lbs
WR6-36-1236-107	20 QSB107	11-5/8" x 8-3/8" x 4"	62 lbs
WR6-36-1236-109	15 QSB109	11-5/8" x 11-1/8" x 4"	64 lbs

HIGH DENSITY WIRE SYSTEMS

High Density Wire Systems

- Wire Storage Systems with bins available in 48", 60" and 72" lengths
- All units in chart below utilize 74" posts and include 12 shelves
- Non-marring caster kit (Model No.: WR-00H) sold separately
- Bins are available in Blue, Green, Ivory, Red, Yellow, Black and Clear

600-800 lb.
Capacity per shelf

MOBILIZE YOUR WIRE SHELVING WITH THESE 2 ACCESSORIES

DB - Donut Bumper

Non-marking donut bumper used to protect walls and help cushion impact.



WR-00H (Mobile Kit)*

Set of four swivel polyurethane 5" x 1-1/4" casters, two with brakes. Can be used with all units shown. 1,200 lb. load capacity.

*Mobile kits recommended only for shelves 18" and wider



WR74-2448-66106 + WR-00H + 4 DB

BIN DIMENSIONS L" x W" x H"	HIGH DENSITY WIRE SYSTEMS								
	48"L SYSTEMS			60"L SYSTEMS			72"L SYSTEMS		
	MODEL NO.	NO. OF BINS	SHIP WGT	MODEL NO.	NO. OF BINS	SHIP WGT	MODEL NO.	NO. OF BINS	SHIP WGT
	12"W x 48"L Units			12"W x 60"L Units			12"W x 72"L Units		
11-5/8" x 4-1/8" x 4"	WR74-1248-110101	110 QSB101	152 lbs	WR74-1260-143101	143 QSB101	208 lbs	WR74-1272-176101	176 QSB101	248 lbs
11-5/8" x 4-1/8" x 4"	WR74-1248-101102	55 QSB101	148 lbs	WR74-1260-101102	78 QSB101	213 lbs	WR74-1272-101102	80 QSB101	240 lbs
11-5/8" x 6-5/8" x 4"		36 QSB102		40 QSB102		60 QSB102			
11-5/8" x 6-5/8" x 4"	WR74-1248-66102	66 QSB102	140 lbs	WR74-1260-88102	88 QSB102	193 lbs	WR74-1272-110102	110 QSB102	230 lbs
	18"W x 48"L Units			18"W x 60"L Units			18"W x 72"L Units		
17-7/8" x 4-1/8" x 4"	WR74-1848-110103	110 QSB103	168 lbs	WR74-1860-143103	143 QSB103	224 lbs	WR74-1872-176103	176 QSB103	264 lbs
17-7/8" x 4-1/8" x 4"	WR74-1848-103104	55 QSB103	164 lbs	WR74-1860-103104	78 QSB103	229 lbs	WR74-1872-103104	80 QSB103	256 lbs
17-7/8" x 6-5/8" x 4"		36 QSB104		40 QSB104		60 QSB104			
17-7/8" x 6-5/8" x 4"	WR74-1848-66104	66 QSB104	156 lbs	WR74-1860-88104	88 QSB104	209 lbs	WR74-1872-110104	110 QSB104	246 lbs
	24"W x 48"L Units			24"W x 60"L Units			24"W x 72"L Units		
23-5/8" x 4-1/8" x 4"	WR74-2448-110105	110 QSB105	180 lbs	WR74-2460-143105	143 QSB105	256 lbs	WR74-2472-176105	176 QSB105	312 lbs
23-5/8" x 4-1/8" x 4"	WR74-2448-105106	55 QSB105	176 lbs	WR74-2460-105106	78 QSB105	261 lbs	WR74-2472-105106	80 QSB105	304 lbs
23-5/8" x 6-5/8" x 4"		36 QSB106		40 QSB106		60 QSB106			
23-5/8" x 6-5/8" x 4"	WR74-2448-66106	66 QSB106	168 lbs	WR74-2460-88106	88 QSB106	241 lbs	WR74-2472-110106	110 QSB106	294 lbs

48"L - 800 lb. Capacity/Shelf

60"L - 600 lb. Capacity/Shelf

72"L - 600 lb. Capacity/Shelf

STORE-MORE 6" SHELF BINS



LOW COST! LONG LASTING! UNBREAKABLE! REUSABLE!

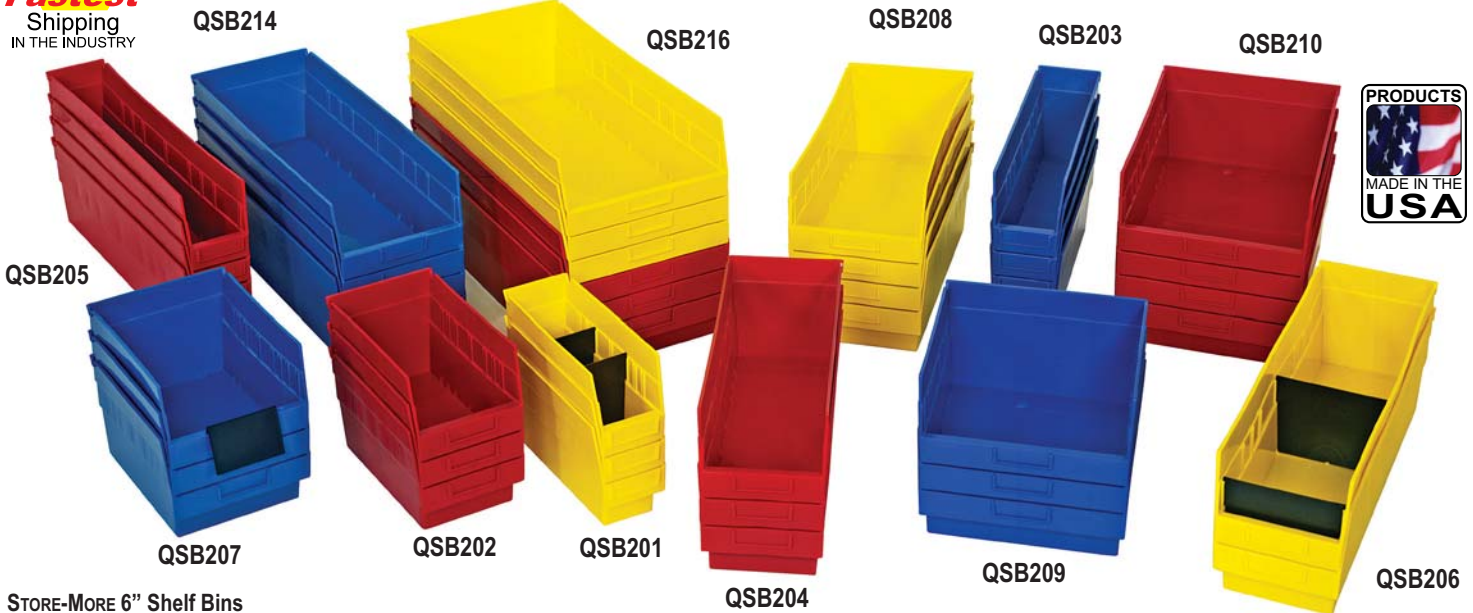

STORE-MORE 6" Shelf Bins

Maximize your storage space with durable, high density polypropylene bins. Quantum's exclusive STORE-MORE 6"H Shelf Bins are the industry standard for quality. These bins feature a molded-in label holder, built-in rear hang-lock which allows bins to tilt out for complete access when on shelving. A wide hopper front allows complete access to the contents of the bin. Edges are reinforced for added strength. They are designed for 12", 18" and 24" deep shelf units, racks or standard shelving. Optional dividers are a perfect solution to create a par level system. Bins are waterproof and corrosion-free. Available in Blue, Yellow and Red.

LOWEST PRICE GUARANTEED!



with **68%** more storage capacity over standard 4" shelf bins, Quantum's

STORE-MORE 6" Shelf Bins

are an industry first and now an industry standard.



Clear Label Holder

Clear Label Holders are available for Economy Shelf Bins & STORE-MORE Shelf Bins. Laser & Inkjet compatible inserts. Label holders fit all shelf bins (except QSB100). Package of 25. Model No.: LTR-0813

Dividers

Optional black dividers fit snugly, horizontally across bins to create compartments. Each bin accepts up to 8 dividers. Bins have a slot at the very front allowing the open hopper to be closed off creating even more storage.

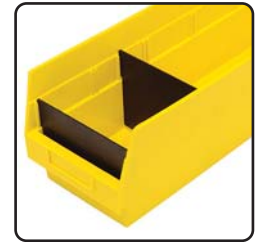

Bin Cups

Bin cups have a raised, slotted label holder for easy parts identification. The entire bin cup may be removed for easy part retrieval. Available in 2 sizes and 2 colors: Blue and Yellow.

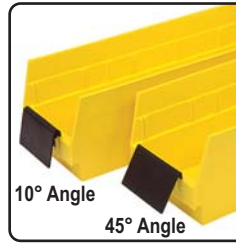

Extended Label Holders

Optional extended label holders are designed for larger bar code scanning. Label holders fit all 6" Shelf Bins.

MODEL NO.	OUTSIDE DIMENSIONS L" x W" x H"	CTN QTY	CTN WGT	MODEL NO.	DESCRIPTION	DIMENSIONS W" x H"	CTN QTY
QBC111	3-1/4" x 1-3/4" x 3"	48	4 lbs	ELH410	10° Angle	4" x 2-1/4"	24
QBC112	5-1/8" x 2-3/4" x 3"	48	7 lbs	ELH445	45° Angle	4" x 2-1/4"	24

MODEL NO.	OUTSIDE DIMENSIONS L" x W" x H"	INSIDE DIMENSIONS L" x W" x H"	CTN QTY	CTN WGT	DIVIDER	CTN QTY	NO. OF BIN CUPS PER BIN QBC111	QBC112
QSB201	11-5/8" x 4-1/8" x 6"	10-1/6" x 3" x 6"	36	19 lbs	DSB201	50	6	2
QSB202	11-5/8" x 6-5/8" x 6"	10-1/6" x 5-1/2" x 6"	30	20 lbs	DSB202	50	9	4
QSB207	11-5/8" x 8-3/8" x 6"	10-1/6" x 7-1/8" x 6"	20	17 lbs	DSB207	50	12	4
QSB209	11-5/8" x 11-1/8" x 6"	10-1/6" x 10" x 6"	8	9 lbs	DSB209	50	18	6
QSB203	17-7/8" x 4-1/8" x 6"	16-1/2" x 3" x 6"	20	15 lbs	DSB203	50	9	3
QSB204	17-7/8" x 6-5/8" x 6"	16-1/2" x 5-1/2" x 6"	20	18 lbs	DSB204	50	15	6
QSB208	17-7/8" x 8-3/8" x 6"	16-1/2" x 7-1/8" x 6"	10	13 lbs	DSB208	50	19	6
QSB210	17-7/8" x 11-1/8" x 6"	16-1/2" x 10" x 6"	8	13 lbs	DSB210	50	29	8
QSB205	23-5/8" x 4-1/8" x 6"	22-1/8" x 3" x 6"	16	15 lbs	DSB205	50	13	4
QSB206	23-5/8" x 6-5/8" x 6"	22-1/8" x 5-1/2" x 6"	8	11 lbs	DSB206	50	21	8
QSB214	23-5/8" x 8-3/8" x 6"	22-1/8" x 7-1/8" x 6"	6	11 lbs	DSB214	50	24	8
QSB216	23-5/8" x 11-1/8" x 6"	22-1/8" x 10" x 6"	6	12 lbs	DSB216	50	35	16

Individual labels are available for all STORE-MORE 6" Shelf Bins. For label Model No. substitute "L" for "Q" in bin Model No.

Ctn Qty: 50 Individual Labels

STORE-MORE SHELF BIN SHELVING SYSTEMS



1275-209

Steel Shelving Shelf Bin Systems

- Complete Steel Packages

- Economical small parts storage systems keep parts easily accessible
- Open hopper front bins with label area, provide fast access to stored items
- This all-in-one unit is easy to clean and will not rust or corrode
- Heavy-duty, high grade shelving offers a 400 lb. capacity per shelf
- 36" wide shelving has a smooth powder coat finish
- Bins are available in Blue, Red and Yellow

COLOR CODE

products to
simplify
order picking
and inventory
control!



**COMPLETE
PACKAGE
with bins!**

**LOWEST
PRICE
GUARANTEED!**

STORE-MORE Shelf Bin Sloped Shelving Systems - Complete Packages

Pick Racks provide a convenient high density, easy access, sloped shelving system, available as bench units, single and double sided free standing and mobile units. Unit comes complete with 6" STORE-MORE Shelf Bins. Sloped shelving unit keeps small and medium sized parts easily accessible. Open hopper front bins with label area, provide fast access to stored items. This all-in-one unit is easy to clean and will not rust or corrode. See chart for configurations. Bins are available in Blue, Red and Yellow. One bin color per unit.

MODEL NO.	NO. OF BINS	BIN SIZE L" x W" x H"	SHIP WGT
BENCH RACKS 12" x 36" x 26-1/2" Unit, 3 Shelves			
QPRHA-201	24 QSB201	11-5/8" x 4-1/8" x 6"	40 lbs
QPRHA-202	15 QSB202	11-5/8" x 6-5/8" x 6"	37 lbs
QPRHA-207	12 QSB207	11-5/8" x 8-3/8" x 6"	36 lbs
QPRHA-209	9 QSB209	11-5/8" x 11-1/8" x 6"	35 lbs
QPRHA-6	BENCH RACK ONLY - NO BINS		
SINGLE SIDED RACKS 12" x 36" x 63-1/2" Unit, 8 Shelves			
QPRS-201	64 QSB201	11-5/8" x 4-1/8" x 6"	89 lbs
QPRS-202	40 QSB202	11-5/8" x 6-5/8" x 6"	81 lbs
QPRS-207	32 QSB207	11-5/8" x 8-3/8" x 6"	79 lbs
QPRS-209	24 QSB209	11-5/8" x 11-1/8" x 6"	77 lbs
QPRS-6	RACK ONLY - NO BINS		
DOUBLE SIDED RACK 24" x 36" x 63-1/2" Unit, 16 Shelves			
QPRD-201	128 QSB201	11-5/8" x 4-1/8" x 6"	178 lbs
QPRD-202	80 QSB202	11-5/8" x 6-5/8" x 6"	162 lbs
QPRD-207	64 QSB207	11-5/8" x 8-3/8" x 6"	158 lbs
QPRD-209	48 QSB209	11-5/8" x 11-1/8" x 6"	154 lbs
QPRD-6	RACK ONLY - NO BINS		
QDU-00	MOBILE KIT - Mobilizes all double sided units		

Eight QSB201, five QSB202, four QSB207, three QSB209, six QUS230, three QUS235, and two QUS245 fit across a standard 36" wide pick rack shelf.

new



QPRS-201
Single Sided Pick Rack
400 lb. capacity.

STORE-MORE WIRE SHELVING PACKAGES



WR9-202
12"W x 36"L x 74"H
9 shelves and 40 QSB202
11-5/8"L x 6-5/8"W x 6"H bins



WR9-207
12"W x 36"L x 74"H
9 shelves and 32 QSB207
11-5/8"L x 8-3/8"W x 6"H bins



WR9-209
12"W x 36"L x 74"H
9 shelves and 24 QSB209
11-5/8"L x 11-1/8"W x 6"H bins

COMPLETE PACKAGES with bins!

Chrome Wire Shelving Shelf Bin Systems

- Complete Wire Packages

- Easy boltless assembly
- Wire allows air to circulate as well as provides ideal product visibility
- Durable chrome finish ensures years of heavy-duty dependability and service
- All welded shelf construction is supported with architectural wire trusses to provide 800 lb. capacity per shelf
- Bins are available in Blue, Yellow and Red

MODEL NO.	NO. OF BINS	BIN SIZE L" x W" x H"
12" x 36" x 74" Unit, 9 Shelves		
WR9-201	64 QSB201	11-5/8" x 4-1/8" x 6"
WR9-202	40 QSB202	11-5/8" x 6-5/8" x 6"
WR9-207	32 QSB207	11-5/8" x 8-3/8" x 6"
WR9-209	24 QSB209	11-5/8" x 11-1/8" x 6"
18" x 36" x 74" Unit, 9 Shelves		
WR9-203	64 QSB203	17-7/8" x 4-1/8" x 6"
WR9-204	40 QSB204	17-7/8" x 6-5/8" x 6"
WR9-208	32 QSB208	17-7/8" x 8-3/8" x 6"
WR9-210	24 QSB210	17-7/8" x 11-1/8" x 6"
24" x 36" x 74" Unit, 9 Shelves		
WR9-205	64 QSB205	23-5/8" x 4-1/8" x 6"
WR9-206	40 QSB206	23-5/8" x 6-5/8" x 6"
WR9-214	32 QSB214	23-5/8" x 8-3/8" x 6"
WR9-216	24 QSB216	23-5/8" x 11-1/8" x 6"

MOBILIZE YOUR WIRE SHELVING WITH THESE 2 ACCESSORIES

DB - Donut Bumper

Non-marking donut bumper used to protect walls and help cushion impact.



WR-00H (Mobile Kit)*

Set of four swivel polyurethane 5" x 1-1/4" casters, two with brakes. Can be used with all units shown. 1,200 lb. load capacity.
*Mobile kits recommended only for shelves 18" and wider



WR9-201
12"W x 36"L x 74"H
9 shelves and 64 QSB201
11-5/8"L x 4-1/4"W x 6"H bins

SUPER TUFF EURO DRAWERS

12" Deep Euro Drawers



QED401



QED501



QED601



QED701



QED801

18" Deep Euro Drawers

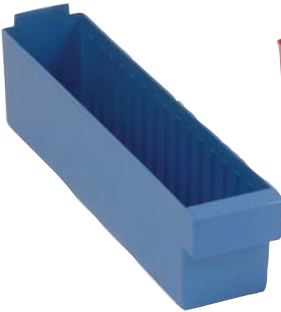

QED604

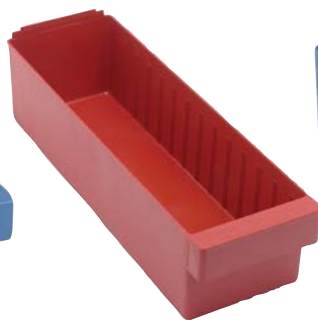

QED602



QED606

24" Deep Euro Drawer



QED603



9 SIZES AVAILABLE!

PERFORMANCE FEATURES AT A GLANCE:

- Available in 9 sizes
- Bins are injection molded from a virgin grade high impact polystyrene and are virtually unbreakable
- Drawers are completely waterproof
- Drawers are oil and chemical resistant
- Smooth front curved pull handle has ample room for pressure sensitive identification labels or bar code
- Front handle has 3/4" opening for convenient easy gripping
- Full width back ledge ensures spill free use
- Optional dividers are full height for extra holding power and prevents mixing of parts
- Available in four colors ideal for color coding inventory: Blue, Yellow, Red and Gray

Full width back ledge ensures spill free use when used on shelving

Multiple divider grooves allow for customized and optimal storage

Smooth front curved pull handle has ample room for pressure sensitive identification labels or bar codes

Multiple molded-in divider slots

Front handle has 3/4" opening for convenient easy gripping

Injection molded from virgin grade high impact polystyrene and are virtually unbreakable

Super Tuff Euro Drawers

Super Tuff Drawers are available in nine sizes and four colors and are designed for efficient organization of heavy parts, supplies, tools or equipment. Super Tuff Euro Drawers are injection molded from a virgin grade high impact polystyrene and are virtually unbreakable. With a full 12 gauge wall thickness, these heavy-duty drawers can be used on Quantum's open and closed shelf units and pick racks. Available in Blue, Yellow, Gray or Red.

MODEL NO.	OUTSIDE DIMENSIONS L" x W" x H"	CTN QTY	CTN WGT	DIVIDER	CTN QTY	NUMBER OF DIVIDER SLOTS
QED401	11-5/8" x 5-9/16" x 2-5/8"	24	17 lbs	DIV401	4	8
QED501	11-5/8" x 3-3/4" x 4-5/8"	24	19 lbs	DIV501/604	4	8
QED601	11-5/8" x 5-9/16" x 4-5/8"	24	24 lbs	DIV6123	4	8
QED701	11-5/8" x 8-3/8" x 4-5/8"	24	31 lbs	DIV701/606	4	8
QED801	11-5/8" x 11-1/8" x 4-5/8"	12	19 lbs	DIV801	4	8
QED604	17-5/8" x 3-3/4" x 4-5/8"	24	29 lbs	DIV501/604	4	15
QED602	17-5/8" x 5-9/16" x 4-5/8"	24	32 lbs	DIV6123	4	13
QED606	17-5/8" x 8-3/8" x 4-5/8"	24	46 lbs	DIV701/606	4	13
QED603	23-7/8" x 5-9/16" x 4-5/8"	12	25 lbs	DIV6123	4	18



**LOWEST
PRICE
GUARANTEED!**

EURO DRAWERS SHELVING SYSTEMS



**Dust Free
& Secure
Storage!**

Fastest
Shipping
IN THE INDUSTRY

CLOSED UNITS
CL1875-624

**COMPLETE PACKAGES
with bins!**



**LOWEST
PRICE
GUARANTEED!**

OPEN UNITS
(No Side or Back Panels)
1239-601

**HIGH DENSITY,
HEAVY-DUTY
STORAGE!**

**More economical solution
compared to higher cost
steel drawer units**

**Open and Closed Shelving Systems with Super Tuff Drawers
- Complete Packages**

Save time locating parts using our tough Euro Drawers with our sturdy open or closed steel shelving. 36" wide x 75" or 39" high units offer heavy-duty, high grade shelving with a 400 lb. capacity per shelf. Closed shelving provides a dust free environment for stored parts. Shelving is Gray, drawers are available in Blue, Yellow, Gray or Red.

CLOSED UNITS			OPEN UNITS
MODEL NO.	NO. OF BINS	BIN SIZE W" x H"	MODEL NO.
12" x 36" x 75", 13 Shelf Unit			
CL1275-401*	108 QED401	5-9/16" x 2-5/8"	1275-401*
CL1275-501	108 QED501	3-3/4" x 4-5/8"	1275-501
CL1275-601	72 QED601	5-9/16" x 4-5/8"	1275-601
CL1275-701	48 QED701	8-3/8" x 4-5/8"	1275-701
CL1275-801	36 QED801	11-1/8" x 4-5/8"	1275-801
CL1275-000	UNIT - NO BINS		1275-000
18" x 36" x 75", 13 Shelf Unit			
CL1875-602	72 QED602	5-9/16" x 4-5/8"	1875-602
CL1875-604	108 QED604	3-3/4" x 4-5/8"	1875-604
CL1875-624	36 QED602	5-9/16" x 4-5/8"	1875-624
	54 QED604	3-3/4" x 4-5/8"	
CL1875-606	48 QED606	8-3/8" x 4-5/8"	1875-606
CL1875-000	UNIT - NO BINS		1875-000
24" x 36" x 75", 13 Shelf Unit			
CL2475-603	72 QED603	5-9/16" x 4-5/8"	2475-603
12" x 36" x 39", 7 Shelf Unit			
CL1239-401**	54 QED401	5-9/16" x 2-5/8"	1239-401**
CL1239-601	36 QED601	5-9/16" x 4-5/8"	1239-601
CL1239-000	UNIT - NO BINS		1239-000
18" x 36" x 39", 7 Shelf Unit			
CL1839-602	36 QED602	5-9/16" x 4-5/8"	1839-602
CL1839-604	54 QED604	3-3/4" x 4-5/8"	1839-604
CL1839-624	18 QED602	5-9/16" x 4-5/8"	1839-624
	27 QED604	3-3/4" x 4-5/8"	
CL1839-000	UNIT - NO BINS		1839-000
24" x 36" x 39", 7 Shelf Unit			
CL2439-603	36 QED603	5-9/16" x 4-5/8"	2439-603

* Unit includes 19 shelves. ** Unit includes 10 shelves.

EURO DRAWERS SLOPED SHELVING SYSTEMS

Euro Drawers Sloped Shelving Units - Complete Packages

Sturdy steel racks with Super Tuff Euro Drawers create an efficient flow rack. Sloped shelving provides easy access to stored items. Drawers can be removed from racks easily. These gray baked enamel, free standing racks assemble easily. Mobile unit has a 500 lb. capacity and is equipped with 2 swivel, 2 rigid casters. Drawers are available in Blue, Yellow, Gray or Red. One bin color per unit.



QPRHA-601
Bench Pick Rack

Comes complete with 18 QED601 Bins.
Has 3 Shelves. 250 lb. capacity.

MODEL NO.	NO. OF BINS	BIN SIZE L" x W" x H"
Bench Unit 12" x 36" x 21" Unit, 3 Shelves		
QPRHA-501	27 QED501	11-5/8" x 3-3/4" x 4-5/8"
QPRHA-601	18 QED601	11-5/8" x 5-9/16" x 4-5/8"
QPRHA-701	12 QED701	11-5/8" x 8-3/8" x 4-5/8"
	9 QED501	11-5/8" x 3-3/4" x 4-5/8"
QPRHA-567	6 QED601	11-5/8" x 5-9/16" x 4-5/8"
	4 QED701	11-5/8" x 8-3/8" x 4-5/8"
Single Sided Rack 12" x 36" x 60" Unit, 8 Shelves		
QPRS-501	72 QED501	11-5/8" x 3-3/4" x 4-5/8"
QPRS-601	48 QED601	11-5/8" x 5-9/16" x 4-5/8"
QPRS-701	32 QED701	11-5/8" x 8-3/8" x 4-5/8"
QPRS-801	24 QED801	11-5/8" x 11-1/8" x 4-5/8"
	18 QED501	11-5/8" x 3-3/4" x 4-5/8"
QPRS-5678	12 QED601	11-5/8" x 5-9/16" x 4-5/8"
	8 QED701	11-5/8" x 8-3/8" x 4-5/8"
	6 QED801	11-5/8" x 11-1/8" x 4-5/8"
Double Sided Rack 24" x 36" x 60" Unit, 16 Shelves		
QPRD-501	144 QED501	11-5/8" x 3-3/4" x 4-5/8"
QPRD-601	96 QED601	11-5/8" x 5-9/16" x 4-5/8"
QPRD-701	64 QED701	11-5/8" x 8-3/8" x 4-5/8"
QPRD-801	48 QED801	11-5/8" x 11-1/8" x 4-5/8"
	36 QED501	11-5/8" x 3-3/4" x 4-5/8"
QPRD-5678	24 QED601	11-5/8" x 5-9/16" x 4-5/8"
	16 QED701	11-5/8" x 8-3/8" x 4-5/8"
	12 QED801	11-5/8" x 11-1/8" x 4-5/8"
QDU-00	MOBILE KIT - Mobilizes all double sided units	

COMPLETE PACKAGES with bins!

**LOWEST
PRICE
GUARANTEED!**



QPRS-601
Single Sided Pick Rack

Comes complete with 48 QED601 Bins.
Has 8 Shelves. 400 lb. capacity.

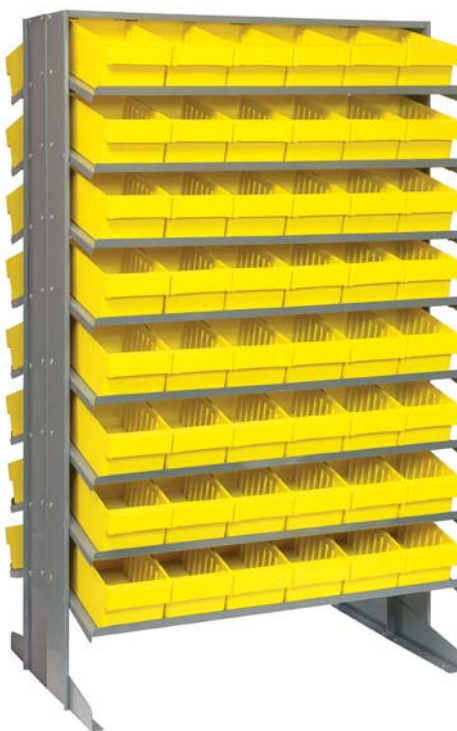

QPRD-601
Double Sided Pick Rack

Comes complete with 96 QED601 Bins.
Has 16 Shelves. 800 lb. capacity.

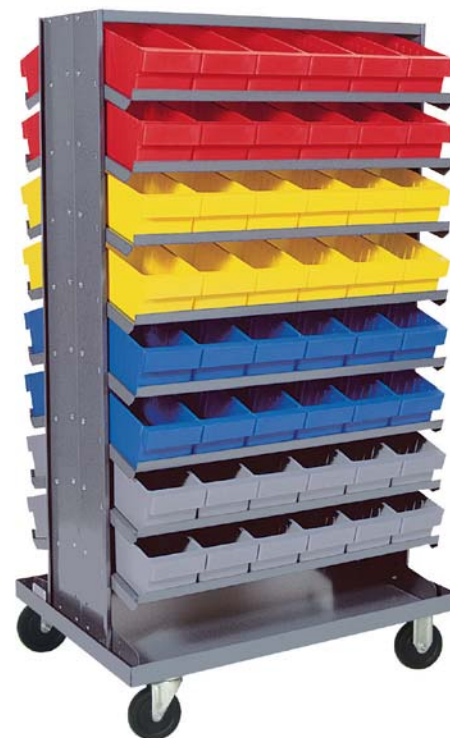

QPRD-601 + QDU-00
Mobile, Double Sided Pick Rack

Comes complete with 96 QED601 Bins.
Has 16 Shelves. 1,000 lb. capacity.

QUICKPICK BINS AND WIRE SHELVING SYSTEMS



Double reinforced sides add strength and prevents bin from spreading when stacked

Stack 'em

Large label slot on both sides

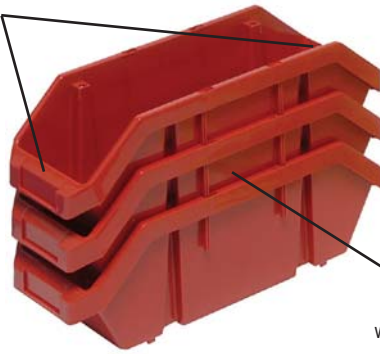

Built-in stacking ledges allow secure stacking and cross stacking

Bins nest when empty to save space

Nest 'em

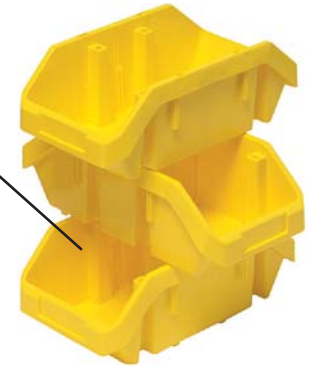

Cross Stack 'em



The most **VERSATILE** bin in the industry!



Create up to **4** compartments



Optional dividers may be used front to back, side to side or both at the same time, dividing the bin into four sections

QuickPick Bin

The most unique storage bins available!

This double open hopper bin provides front and back access to stored parts.

These heavy-duty, polypropylene storage bins provide an open hopper front and back, allowing double access to stored parts. Bins stack one on top of the other, both vertically and cross-wise, and nest when empty for space efficiency. Optional dividers may be used front to back, side to side or both at the same time, dividing the bin into four sections. A molded in label holder on both the front and back of the bin allows for easy parts identification. Bins can be used on standard metal or wire shelving as well as on desks, bench tops or work stations. Available in 6 sizes and in 3 colors: Blue, Yellow and Red.

MODEL NO.	DIMENSIONS L" x W" x H"	CTN QTY	CTN WGT	CROSS DIVIDER	CTN QTY	LENGTH DIVIDER	CTN QTY
QP965	9-1/2" x 6-5/8" x 5"	20	15 lbs	CD965	10	LD965	10
QP1265	12-1/2" x 6-5/8" x 5"	20	19 lbs	CD1265	10	LD1265	10
QP1285	12-1/2" x 8-3/8" x 5"	20	22 lbs	CD1285	10	LD1285	10
QP1496	14" x 9-1/4" x 6-1/2"	20	26 lbs	CD1496	10	LD1496	10
QP1867	18-1/2" x 6-5/8" x 7"	10	16 lbs	CD1867	10	LD1867	10
QP1887	18-1/2" x 8-3/8" x 7"	10	18 lbs	CD1887	10	LD1887	10

DOUBLE SIDED ACCESS!

Heavy-duty Wire Shelving with QuickPick Bins - Complete Packages

These unique shelving packages provide "double" access to stored parts. QuickPick Bins allow two users to access stored product at the same time! This ergonomic, space efficient work station is the ultimate space saver! Shelving units measure 18"W x 36"L x 74"H and may be ordered with or without a mobile kit. These heavy-duty units offer an 800 lb. capacity per shelf. Optional dividers may be used front to back, side to side or both at the same time, dividing the bin into four sections. See chart above for ordering instructions. A molded in label holder on both the front and back of the bin allows for easy part identification.

MODEL NO.	NO. OF BINS	DIMENSIONS L" x W" x H"	SHIP WGT
W7-12-30	30	12-1/2" x 6-5/8" x 5"	110 lbs
W7-12-26	10	12-1/2" x 6-5/8" x 5"	107 lbs
W7-12-28	16	12-1/2" x 8-3/8" x 5"	109 lbs
	8	12-1/2" x 8-3/8" x 5"	
W7-12-24	24	12-1/2" x 8-3/8" x 5"	106 lbs
W7-14-18	18	14" x 9-1/4" x 6-1/2"	105 lbs
W7-18-30	30	18-1/2" x 6-5/8" x 7"	128 lbs
W7-18-26	10	18-1/2" x 6-5/8" x 7"	125 lbs
	16	18-1/2" x 8-3/8" x 7"	
W7-18-28	20	18-1/2" x 6-5/8" x 7"	127 lbs
	8	18-1/2" x 8-3/8" x 7"	
W7-18-24	24	18-1/2" x 8-3/8" x 7"	124 lbs
Mobile Kit			
WR-00H	Mobilizes Wire Shelving Unit		14 lbs



W7-12-26

Fastest Shipping IN THE INDUSTRY

LOWEST PRICE GUARANTEED!



WRC2-1836-1867

QuickPick Bin Mobile Wire Cart

Mobile double sided cart with bins.

These heavy-duty, polypropylene storage bins provide an open hopper front and back, allowing double access to stored parts. Unit comes in a 2 or 3 shelf configuration complete with four casters (all swivel and two with brakes). Overall dimensions: 18"W x 36"L x 37-1/2"H. Mobile cart is easy to assemble. Bins are available in 3 colors: Blue, Yellow and Red. One color per unit. See chart above to order Length and/or Cross Dividers.

MODEL NO.	NO. OF BINS	BIN DIMENSIONS L" x W" x H"	SHIP WGT
WRC2-1836-1265	10	12-1/2" x 6-5/8" x 5"	49 lbs
WRC3-1836-1265	15	12-1/2" x 6-5/8" x 5"	64 lbs
WRC2-1836-1285	8	12-1/2" x 8-3/8" x 5"	48 lbs
WRC3-1836-1285	12	12-1/2" x 8-3/8" x 5"	63 lbs
WRC2-1836-1867	10	18-1/2" x 6-5/8" x 7"	55 lbs
WRC3-1836-1867	15	18-1/2" x 6-5/8" x 7"	73 lbs
WRC2-1836-1887	8	18-1/2" x 8-3/8" x 7"	54 lbs
WRC3-1836-1887	12	18-1/2" x 8-3/8" x 7"	72 lbs

HIGH PERFORMANCE STACK AND LOCK BINS

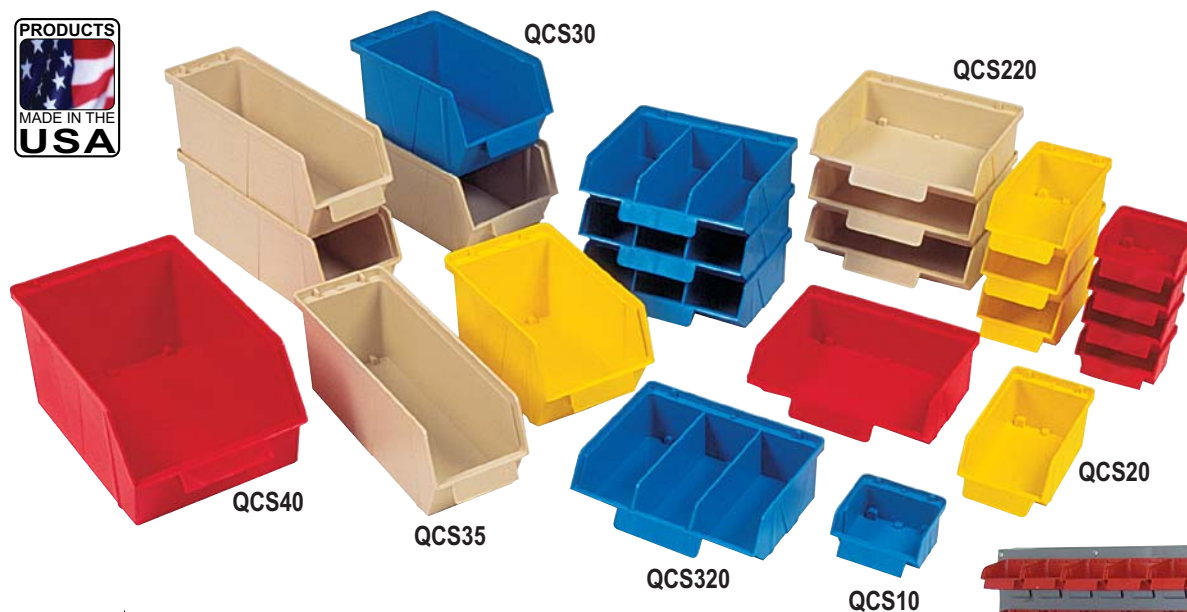

Fastest
Shipping
IN THE INDUSTRY

LOWEST PRICE
GUARANTEED!

PERFORMANCE FEATURES AT A GLANCE:

- Available in 7 unique sizes
- Front identification tab ideal for gripping and handling
- Reinforced ribs - add strength and prevent spreading
- Full length rear hanger for added support and hanging capability

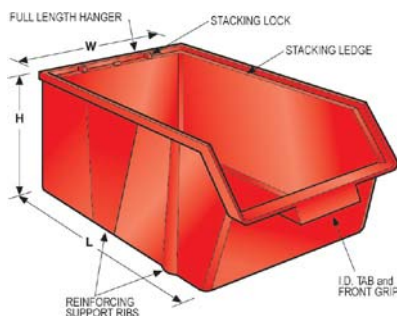

The Open Hopper Stack and Lock Bin

These Classic bins are all purpose open hoppers, made from high impact polystyrene. They will stack and lock on one another, and hang on Quantum louvered panels, rails and carts to form an efficient system for storing and moving parts. They can also be used on Quantum Shelf Units and standard shelving. Available in Blue, Yellow, Red and Ivory.

MODEL NO.	OUTSIDE DIMENSIONS L" x W" x H"	CTN QTY	CTN WGT
QCS10	4" x 3-7/8" x 2"	48	7 lbs
QCS20	7" x 3-7/8" x 2-7/8"	48	13 lbs
QCS220	7" x 8-7/8" x 2-7/8"	24	13 lbs
QCS320*	7" x 8-7/8" x 2-7/8"	24	16 lbs
QCS30	10-1/4" x 5-7/8" x 5-1/8"	12	11 lbs
QCS35	14" x 4-5/8" x 4-7/8"	12	14 lbs
QCS40	13-1/2" x 8-1/8" x 6-1/8"	8	12 lbs

* Three divided sections - each section is 2-5/8"W

COMPLETE PACKAGE with bins!

MODEL NO.	NO. OF BINS
QCS-156	156 Bins

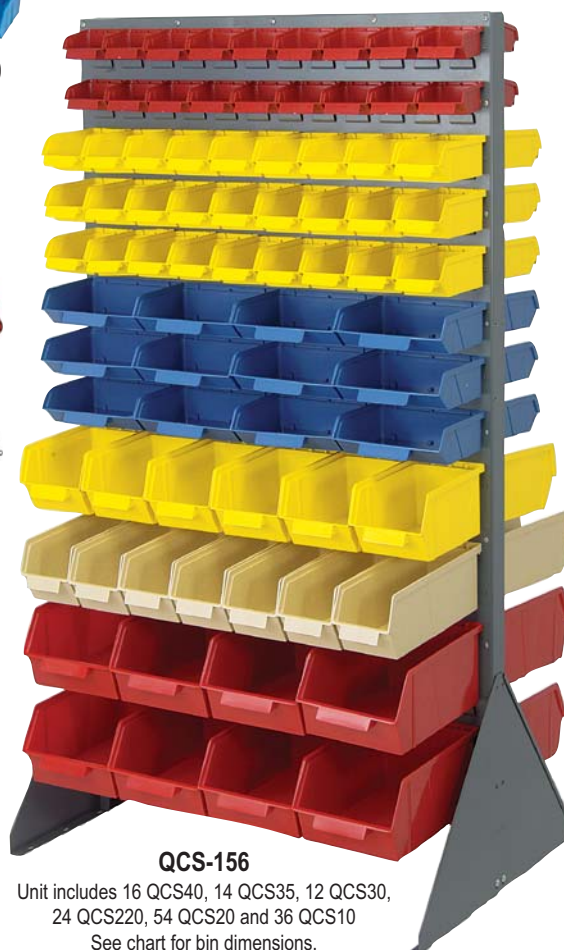

QCS-156

Unit includes 16 QCS40, 14 QCS35, 12 QCS30, 24 QCS220, 54 QCS20 and 36 QCS10
See chart for bin dimensions.

Color code your small parts!



Patient Drawers

Drawers are available in four sizes and are ideal for storing patient supplies and medications. All drawers come complete with a clear window. Optional dividers may be purchased separately. See page 64 to order drawers in an Interlocking Storage Cabinet unit.

MODEL NO.	DIMENSIONS L" x W" x H"	CTN QTY	CTN WGT	DIVIDER	CTN QTY	CTN WGT
IDR201	11" x 2-3/4" x 2-1/2"	24	9 lbs	DIV201	25	1 lb
IDR202	11" x 2-3/4" x 3-5/16"	24	12 lbs	DIV202	25	1 lb
IDR203	11" x 5-5/8" x 2-1/2"	24	14 lbs	DIV203	25	1 lb
IDR204	11" x 5-5/8" x 3-5/16"	24	22 lbs	DIV204	25	2 lbs

RECYCLED BINS

Environmentally Friendly Recycled Bins

Manufactured from recycled, 100% post consumer, high density polypropylene, these bins come in a complete range of sizes and have all the features of Quantum's standard bins at a more economical price. Available in Black only.



Recycled Ultra Hang & Stack Bins

See page 13 for additional information on Ultra Hang & Stack Bins and to order windows or dividers.



Recycled Shelf Bins

See page 41 for additional information on Shelf Bins and to order dividers and bin cups.



Recycled MAGNUM Bins

See page 33 for additional information on MAGNUM Bins and to order windows, dividers or a mobile option.



MODEL NO.	OUTSIDE DIMENSIONS L" x W" x H"	CTN QTY	CTN WGT
QUS200BR	5" x 4-1/8" x 3"	24	5 lbs
QUS210BR	5-3/8" x 4-1/8" x 3"	24	6 lbs
QUS220BR	7-3/8" x 4-1/8" x 3"	24	8 lbs
QUS221BR	9-1/4" x 6" x 5"	24	8 lbs
QUS224BR	10-7/8" x 4-1/8" x 4"	12	8 lbs
QUS230BR	10-7/8" x 5-1/2" x 5"	12	10 lbs
QUS233BR	13-1/2" x 5-1/2" x 5"	12	13 lbs
QUS234BR	14-3/4" x 5-1/2" x 5"	12	14 lbs
QUS235BR	10-7/8" x 11" x 5"	6	10 lbs
QUS239BR	10-3/4" x 8-1/4" x 7"	6	10 lbs
QUS240BR	14-3/4" x 8-1/4" x 7"	12	24 lbs
QUS241BR	13-5/8" x 8-1/4" x 6"	12	24 lbs
QUS242BR	13-5/8" x 8-1/4" x 8"	12	24 lbs
QUS245BR	10-7/8" x 16-1/2" x 5"	6	13 lbs
QUS250BR	14-3/4" x 16-1/2" x 7"	6	21 lbs
QUS255BR	16" x 11" x 8"	4	14 lbs
QUS260BR	18" x 11" x 10"	4	17 lbs
QUS265BR	18" x 8-1/4" x 9"	6	17 lbs
QUS270BR	18" x 16-1/2" x 11"	3	16 lbs
QUS275MOBBR	18" x 16-1/2" x 11"	6	19 lbs
QGH700BR	15-1/4" x 19-7/8" x 12-7/16"	3	13 lbs

MODEL NO.	OUTSIDE DIMENSIONS L" x W" x H"	CTN QTY	CTN WGT
QSB100BR	11-5/8" x 2-3/4" x 4"	36	13 lbs
QSB101BR	11-5/8" x 4-1/8" x 4"	36	17 lbs
QSB102BR	11-5/8" x 6-5/8" x 4"	30	18 lbs
QSB107BR	11-5/8" x 8-3/8" x 4"	20	15 lbs
QSB109BR	11-5/8" x 11-1/8" x 4"	8	7 lbs
QSB103BR	17-7/8" x 4-1/8" x 4"	20	13 lbs
QSB104BR	17-7/8" x 6-5/8" x 4"	20	16 lbs
QSB108BR	17-7/8" x 8-3/8" x 4"	10	11 lbs
QSB110BR	17-7/8" x 11-1/8" x 4"	8	11 lbs
QSB105BR	23-5/8" x 4-1/8" x 4"	16	13 lbs
QSB106BR	23-5/8" x 6-5/8" x 4"	8	9 lbs
QSB114BR	23-5/8" x 8-3/8" x 4"	6	9 lbs
QSB116BR	23-5/8" x 11-1/8" x 4"	6	10 lbs

MODEL NO.	OUTSIDE DIMENSIONS L" x W" x H"	CTN QTY	CTN WGT
QMS531BR	19-3/4" x 12-3/8" x 5-7/8"	6	19 lbs
QMS532BR	19-3/4" x 12-3/8" x 7-7/8"	6	23 lbs
QMS533BR	19-3/4" x 12-3/8" x 11-7/8"	3	15 lbs
QMS543BR	19-3/4" x 18-3/8" x 11-7/8"	1	8 lbs
QMS743BR	29" x 18-3/8" x 11-7/8"	1	10 lbs

MANUFACTURED
from recycled,
100% post consumer,
high density polypropylene

CONDUCTIVE BINS, HANGING SYSTEMS & RACKS



Conductive Ultra Stack Bins and Dividers

Protect your electronic components from typical electromagnetic interference (EMI), electrostatic or induced fields with these conductive polypropylene bins. The conductive material provides a barrier which these fields cannot penetrate and prevents the build-up of electrostatic charge. Bins are permanently conductive and are unaffected by washing with normal cleaners. Molded from a carbon filled copolymer polypropylene material with an electrostatic decay rate at less than 0.1 second that meets military specification Mil-B-81075B. Its surface resistivity is less than 10^5 Ohms-per square. Easy access to stored items with hopper front bin and label holder provides fast identification. Reinforced side walls and wide ledge allow high stacking on benches or shelving. Be sure all units are properly grounded according to your use. Color is Black.

MODEL NO.	OUTSIDE DIMENSIONS L" x W" x H"	CTN QTY	CTN WGT	DIVIDER	CTN QTY
QUS205CO	4-1/2" x 4-1/8" x 3"	24	5 lbs	DUS205CO	6
QUS210CO	5-3/8" x 4-1/8" x 3"	24	6 lbs	DUS210CO	6
QUS220CO	7-3/8" x 4-1/8" x 3"	24	8 lbs	DUS220CO	6
QUS230CO	10-7/8" x 5-1/2" x 5"	12	12 lbs	DUS230CO	6
QUS233CO	13-1/2" x 5-1/2" x 5"	12	13 lbs	DUS233CO	6
QUS235CO	10-7/8" x 11" x 5"	6	10 lbs	DUS235CO	6
QUS239CO	10-3/4" x 8-1/4" x 7"	6	10 lbs	DUS239CO	6
QUS240CO	14-3/4" x 8-1/4" x 7"	12	24 lbs	DUS240CO	6
QUS250CO	14-3/4" x 16-1/2" x 7"	6	21 lbs	DUS250CO	6
QUS255CO	16" x 11" x 8"	4	14 lbs	DUS255CO	6
QUS260CO	18" x 11" x 10"	4	17 lbs	DUS260CO	6
QUS270CO	18" x 16-1/2" x 11"	3	16 lbs	DUS270CO	6

Customize your own unit!

1. Select the unit of your choice.
2. Use the chart above and choose which bin would best fit your needs.
3. Go to the chart at the bottom of this page and determine how many bins fit on the unit you selected.
4. Place your order for both unit and bins (Sold in carton quantities).



Conductive Stack & Lock Bins

Be sure all units are properly grounded according to your use. See page 53 for non-conductive Stack & Lock Bins. Color is Black.

MODEL NO.	OUTSIDE DIMENSIONS L" x W" x H"	CTN QTY	CTN WGT
QCS10CO	4" x 3-7/8" x 2"	48	7 lbs
QCS20CO	7" x 3-7/8" x 2-7/8"	48	14 lbs
QCS30CO	10-1/4" x 5-7/8" x 5-1/8"	12	12 lbs
QCS35CO	14" x 4-5/8" x 4-7/8"	12	15 lbs
QCS40CO	13-1/2" x 8-1/8" x 6-1/8"	8	13 lbs

LARGEST CONDUCTIVE SELECTION AVAILABLE ANYWHERE!

Single Sided, Double Sided and Double Sided Mobile Rail Systems

All conductive metal racks and bins resist static build-up. Bins are easily removed, refilled and replaced. All metal components have a powder coated conductive finish which provides years of heavy-duty service. Be sure all units are properly grounded according to your use.

QRU-16DCO - Double Sided Rack 16 Rails

Accepts 3 sizes of Ultra bins (up to 96 bins) 500 lb. capacity. See chart for combinations. Bins sold separately. Be sure all units are grounded according to your use.



QRU-16SCO
(Bins sold separately)



QRU-16DCO +
QRU-MOBSCO
(Bins sold separately)

QUANTITY OF ULTRA BINS TO FIT RAIL UNITS

MODEL NO.	DESCRIPTION	DIMENSIONS L" x W" x H"	QUS 205	QUS 210	QUS 220	QUS 230	QUS 233	QUS 235	QUS 239	QUS 240	QUS 250	QUS 255	QUS 260	QUS 270
QRU-12SCO	Rack, 1 Sided 12 Rail	36" x 15" x 53"	96	96	96	-	-	-	24	24	12	12	12	8
QRU-16SCO	Rack, 1 Sided 16 Rail	36" x 15" x 53"	-	-	-	48	48	24	-	-	-	-	-	-
QRU-12DCO	Rack, 2 Sided 12 Rail	36" x 20" x 53"	192	192	192	-	-	-	48	48	24	24	24	16
QRU-16DCO	Rack, 2 Sided 16 Rail	36" x 20" x 53"	-	-	-	96	96	48	-	-	-	-	-	-
QRU-MOBSCO	Mobilizes Double Sided Units													

See chart above for bin dimensions



CONDUCTIVE HANGING SYSTEMS & RACKS

QLP-1819CO Conductive Louvered Panel

18"L x 19"H. Accepts all sizes of Conductive Ultra Bins. Bins sold separately. See page 55 for bin dimensions. Be sure all units are properly grounded according to your use. See chart below for additional sizes.

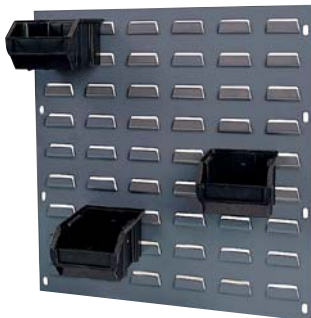

QBR-3619CO Conductive Bench Rack

36"L x 8"W x 19"H. Bench rack accepts 9 sizes of Ultra Bins. Bins sold separately. See chart below for additional sizes.

MODEL NO.	DIMENSIONS L" x H"	CTN QTY	SHIP WGT
QLP-1819CO	18" x 19" Louvered Panel	1	6 lbs
QLP-1861CO	18" x 61" Louvered Panel	1	21 lbs
QLP-2721CO	27" x 21" Louvered Panel	1	11 lbs
QLP-3612CO	36" x 12" Louvered Panel	1	8 lbs
QLP-3619CO	36" x 19" Louvered Panel	1	13 lbs
QLP-3661CO	36" x 61" Louvered Panel	1	40 lbs
QLP-4819CO	48" x 19" Louvered Panel	1	18 lbs
QLP-4861CO	48" x 61" Louvered Panel	1	60 lbs

MODEL NO.	DIMENSIONS L" x W" x H"	CTN QTY	SHIP WGT
QBR-1819CO	18" x 8" x 19" Bench Rack	1	8 lbs
QBR-2721CO	27" x 8" x 21" Bench Rack	1	16 lbs
QBR-3612CO	36" x 8" x 12" Bench Rack	1	14 lbs
QBR-3619CO	36" x 8" x 19" Bench Rack	1	19 lbs

QMD-36HCO Mobile Double Sided Louvered Rack

36"L x 25"W x 72"H Mobile unit accepts all sizes of Ultra Bins (up to 240 bins, 1,200 lb. capacity). Bins sold separately. See page 55 for bin dimensions. Be sure all units are properly grounded according to your use.

MODEL NO.	DIMENSIONS L" x W" x H"	CTN QTY	SHIP WGT
Single Sided Unit - 375 lb. capacity			
QSS-1866HCO	18"L x 12-1/2"W x 66"H	1	40 lbs
Single Sided Unit - 800 lb. capacity			
QSS-3666HCO	36"L x 12-1/2"W x 66"H	1	60 lbs
Double Sided Unit - 2,000 lb. capacity			
QDS-3666HCO	36"L x 25"W x 66"H	1	106 lbs
Double Sided, Mobile Unit - 1,200 lb. capacity			
QMD-36HCO	36"L x 25"W x 72"H	1	112 lbs



Customize your own unit!

1. Select the unit of your choice.
2. Use the chart on page 55 and choose which bin would best fit your needs.
3. Go to the chart on the right and determine how many bins fit on the unit you selected.
4. Place your order for both unit and bins (Sold in carton quantities).

Fastest
Shipping
IN THE INDUSTRY

**LOWEST
PRICE
GUARANTEED!**

QUANTITY OF ULTRA BINS TO FIT LOUVERED PANELS

MODEL NO.	QUS 205CO	QUS 210CO	QUS 220CO	QUS 230CO	QUS 233CO	QUS 235CO	QUS 239CO	QUS 240CO	QUS 250CO	QUS 255CO	QUS 260CO	QUS 270CO
QLP-1819CO	16	16	16	9	9	3	4	4	2	1	1	1
QLP-1861CO	60	60	60	30	30	15	14	14	7	7	5	5
QLP-2721CO	30	30	30	12	12	6	6	6	2	4	4	1
QLP-3612CO	18	18	18	12	12	6	4	4	2	6	3	2
QLP-3619CO	32	32	32	18	18	9	8	8	4	6	3	2
QLP-3661CO	120	120	120	60	60	30	28	28	14	21	15	10
QLP-4819CO	40	40	40	24	24	12	10	10	4	8	8	2
QLP-4861CO	165	165	165	80	80	40	35	35	14	28	20	10
QBR-1819CO	16	16	16	9	9	3	4	4	2	1	1	1
QBR-2721CO	30	30	30	12	12	6	6	6	2	4	4	1
QBR-3612CO	18	18	18	12	12	6	4	4	2	6	3	2
QBR-3619CO	32	32	32	18	18	9	8	8	4	6	3	2
QSS-1866HCO	60	60	60	30	30	15	14	14	7	7	5	5
QSS-3666HCO	12	12	12	60	60	30	28	28	14	21	15	10
QDS-3666HCO	240	240	240	120	120	60	56	56	28	42	30	20
QMD-36HCO	240	240	240	120	120	60	56	56	28	42	30	20

See page 55 for bin dimensions

CONDUCTIVE SHELF BINS & DIVIDABLE CONTAINERS

Conductive Shelf Bins

Protect your electronic components from typical electromagnetic interference (EMI), electrostatic or induced fields with these molded, carbon-filled, copolymer polypropylene bins. Surface resistivity is less than 10⁵ Ohms-per square. Easy access to stored items with hopper front bin and label holder provides fast identification. The conductive material provides a barrier which these fields cannot penetrate and prevents the build-up of electrostatic charge. Bins are permanently conductive and are unaffected by washing with normal cleaners. Be sure all units are properly grounded according to your use. Color is Black.

MODEL NO.	OUTSIDE DIMENSIONS L" x W" x H"	CTN QTY	CTN WGT	DIVIDER	CTN QTY
QSB100CO	11-5/8" x 2-3/4" x 4"	36	14 lbs	-	-
QSB101CO	11-5/8" x 4-1/8" x 4"	36	17 lbs	DSB101CO	50
QSB102CO	11-5/8" x 6-5/8" x 4"	30	18 lbs	DSB102CO	50
QSB107CO	11-5/8" x 8-3/8" x 4"	20	15 lbs	DSB107CO	50
QSB109CO	11-5/8" x 11-1/8" x 4"	8	8 lbs	DSB109CO	50
QSB103CO	17-7/8" x 4-1/8" x 4"	20	13 lbs	DSB103CO	50
QSB104CO	17-7/8" x 6-5/8" x 4"	20	18 lbs	DSB104CO	50
QSB108CO	17-7/8" x 8-3/8" x 4"	10	10 lbs	DSB108CO	50
QSB110CO	17-7/8" x 11-1/8" x 4"	8	12 lbs	DSB110CO	50
QSB105CO	23-5/8" x 4-1/8" x 4"	16	14 lbs	DSB105CO	50
QSB106CO	23-5/8" x 6-5/8" x 4"	8	12 lbs	DSB106CO	50
QSB114CO	23-5/8" x 8-3/8" x 4"	6	10 lbs	DSB114CO	50
QSB116CO	23-5/8" x 11-1/8" x 4"	6	11 lbs	DSB116CO	50

12", 18" & 24" DEPTHS!



**13 SIZES
TO CHOOSE FROM!**



LARGEST CONDUCTIVE SELECTION AVAILABLE ANYWHERE!



Conductive Dividable Grid Containers

Protect your electronic components from typical electromagnetic interference (EMI), electrostatic or induced fields with these molded, carbon-filled, copolymer polypropylene dividable grid containers. Surface resistivity is less than 10⁵ Ohms-per square. The conductive material provides a barrier which these fields cannot penetrate and prevents the build-up of electrostatic charge. Containers, dividers and covers are permanently conductive and are unaffected by washing with normal cleaners. Containers have a load capacity of 100 lbs. Dividers available to customize your box into compartments at 1-1/8" intervals and snap covers protect contents from dust or damage. Be sure all units are properly grounded according to your use. Color is Black.



Dividers



Snap On Covers



Clear Label Holders

MODEL NO.	DIMENSIONS H" x W"	FITS BIN MODEL NO.	CTN QTY
LBL2X8CO	2" x 8"	DG91035CO, DG92035CO, DG93030CO	6
LBL3X5CO	3" x 5"	DG91050CO, DG92060CO, DG93060CO	6
LBL5X8CO	5" x 8"	DG92080CO, DG93080CO, DG93120CO	6

MODEL NO.	OUTSIDE DIMENSIONS L" x W" x H"	CTN QTY	CTN WGT	LONG DIVIDER	CTN QTY	SHORT DIVIDER	CTN QTY	COVER	CTN QTY
DG91035CO	10-7/8" x 8-1/4" x 3-1/2"	20	24 lbs	DL91035CO	6	DS91035CO	6	COV91000CO	10
DG91050CO	10-7/8" x 8-1/4" x 5"	20	32 lbs	DL91050CO	6	DS91050CO	6	COV91000CO	10
DG92035CO	16-1/2" x 10-7/8" x 3-1/2"	12	23 lbs	DL92035CO	6	DS92035CO	6	COV92000CO	4
DG92060CO	16-1/2" x 10-7/8" x 6"	8	20 lbs	DL92060CO	6	DS92060CO	6	COV92000CO	4
DG92080CO	16-1/2" x 10-7/8" x 8"	8	27 lbs	DL92080CO	6	DS92080CO	6	COV92000CO	4
DG93030CO	22-1/2" x 17-1/2" x 3"	6	20 lbs	DL93030CO	6	DS93030CO	6	COV93000CO	3
DG93060CO	22-1/2" x 17-1/2" x 6"	3	19 lbs	DL93060CO	6	DS93060CO	6	COV93000CO	3
DG93080CO	22-1/2" x 17-1/2" x 8"	3	16 lbs	DL93080CO	6	DS93080CO	6	COV93000CO	3
DG93120CO	22-1/2" x 17-1/2" x 12"	3	23 lbs	DL93120CO	6	DS93120CO	6	COV93000CO	3

Fastest
Shipping
IN THE INDUSTRY

**LOWEST
PRICE
GUARANTEED!**

CLEAR TIP OUT BIN SYSTEMS

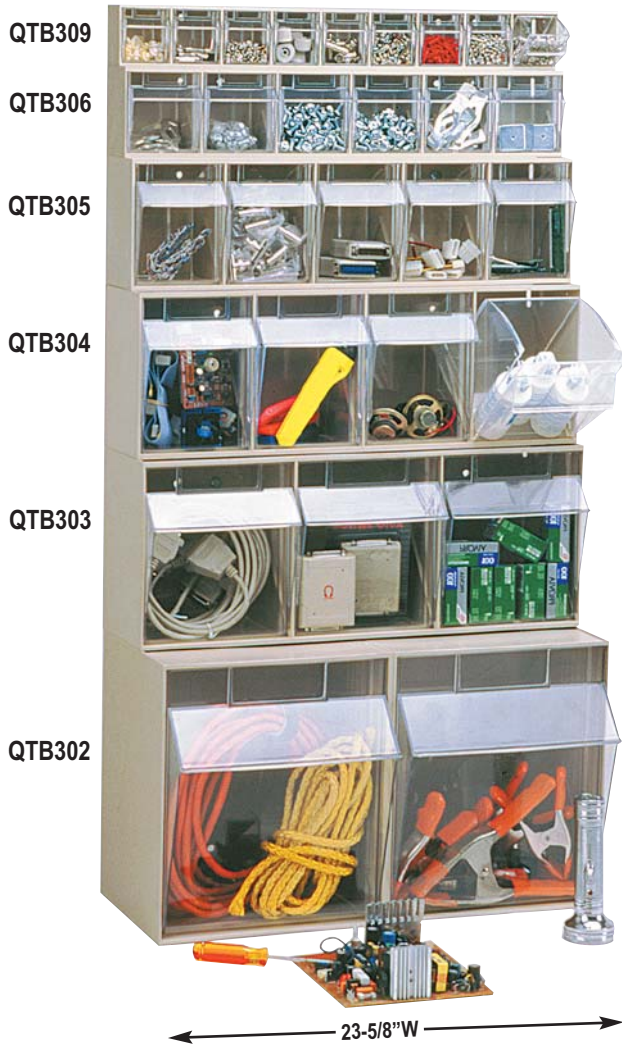

**TIP OUT
BIN**



DIV303 and DIV304
QTB303 and QTB304 cup can use optional divider, as shown above.



Locking Rod
Model No.: QLR500
Keeps bins from tilting open.
Can be used with 23-5/8"W bins.



Louvered Panel Bracket
Model No.: QTB-LP-BKT
Hang bin on louvered panel.
Available in Beige or Gray.
Panels available on page 14.



TIP OUT BIN CLEAR COMPARTMENTS KEEP SMALL ITEMS SORTED AND EASY TO FIND!

Clear Tip Out Bins

Space saving bin units keep small and medium sized parts organized, sorted and easy to find. These clear, break resistant injection molded plastic containers tip open smoothly to a 45° angle and are completely removable for easy access and refilling. Molded handle with slots for labels provided. Bins are easily cleaned with soap and water. Polystyrene cabinet can be stacked or wall mounted. Exterior available in White, Ivory and Gray. Cups are clear. Optional dividers, locking rod and louvered panel bracket also available.

MODEL NO.	OUTSIDE DIMENSIONS L" x W" x H"	BIN DIMENSIONS L" x W" x H"	CTN QTY	CTN WGT
QTB301	11-3/4" x 11-13/16" x 13-7/8"	8-7/8" x 11-1/16" x 13-5/8"	1	7 lbs
QTB302	11-3/4" x 23-5/8" x 13-7/8"	8-7/8" x 11-1/16" x 13-5/8"	1	14 lbs
QTB303	7-3/4" x 23-5/8" x 9-1/2"	5-7/8" x 7-3/8" x 8-5/8"	1	9 lbs
QTB304	6-5/8" x 23-5/8" x 8-1/8"	5" x 5-5/8" x 7-1/2"	1	7 lbs
QTB305	5-1/4" x 23-5/8" x 6-1/2"	3-3/4" x 4-1/4" x 5-3/4"	1	5 lbs
QTB306	3-5/8" x 23-5/8" x 4-1/2"	2-5/8" x 3-1/2" x 3-3/4"	1	2 lbs
QTB309	2-1/2" x 23-5/8" x 3-1/8"	1-3/4" x 2-3/16" x 2-1/2"	1	2 lbs
DIV303	3 Dividers for QTB303		3	2 lbs
DIV304	4 Dividers for QTB304		4	1 lb
QLR500	Locking Rod for 23-5/8"W Tip Out Bins		1	1 lb
QTB-LP-BKT	Louvered Panel Bracket pair for Tip Out Bins		1	1 lb



QTB309
9 Bin - 2-1/2"L x 23-5/8"W x 3-1/8"H



QTB306
6 Bin - 3-5/8"L x 23-5/8"W x 4-1/2"H



QTB305
5 Bin - 5-1/4"L x 23-5/8"W x 6-1/2"H



QTB304
4 Bin - 6-5/8"L x 23-5/8"W x 8-1/8"H



QTB303
3 Bin - 7-3/4"L x 23-5/8"W x 9-1/2"H



QTB302
2 Bin - 11-3/4"L x 23-5/8"W x 13-7/8"H



QTB301
1 Bin - 11-3/4"L x 11-13/16"W x 13-7/8"H

CLEAR TIP OUT BIN SYSTEMS

Dividable Tip Out Bins

These bins feature removable and adjustable dividers so that the clear bin can be partitioned into smaller compartments. Ideal for larger or longer items, these clear Tip Out Bins are molded from the same strong and flexible material as our standard bins. The flexibility of bins allow the user to determine the size and volume of each storage compartment. Exterior available in White, Ivory and Gray. Cups are clear.



**TIP OUT
BIN**

PERFORMANCE FEATURES AT A GLANCE:

- Dividable Tip Out Bins are available in 3 sizes (2 with the same width)
- Bins can be stacked as modular units or used individually
- Exterior housing is injection molded from high impact Polystyrene
- Clear bin cups are injection molded from a custom blend of Phillips K Resin and Crystal Styrene for clarity and durability
- Compartments tip open smoothly to a 45° angle and provide comfortable and complete access to stored items
- The flexibility of the system allows you to customize your own system to meet your specific needs

MODEL NO.	OUTSIDE DIMENSIONS L" x W" x H"	CTN QTY	CTN WGT
QTB410	5-1/4" x 11-7/8" x 5-15/16"	1	3 lbs
QTB411	5-1/4" x 23-5/8" x 5-15/16"	1	4 lbs
QTB412	5-1/4" x 23-5/8" x 5-15/16"	1	4 lbs
DIV400	DIVIDER FOR DIVIDABLE TIP OUT BINS	4	1 lbs



QTB410

QTB410 is a one bin design, 12" wide
Each QTB410 comes with 3 DIV400 clear dividers*



QTB411

QTB411 is a two bin design, each bin 12" wide
Each QTB411 comes with 6 DIV400 clear dividers*



QTB412

QTB412 is a one bin design, 23-5/8" wide
Each QTB412 comes with 5 DIV400 clear dividers*
*Note: Dividers shown in white color for clarity.



QTB405



QTB406



QTB409



Individual Tip Out Bins

These unique bins have the ability to interlock horizontally or vertically. Available in three popular sizes, these bins allow you to create your own customized Tip Out Bin storage system. QTB405 and QTB406 are available in White, Ivory and Gray. QTB409 is available in White, Red, Blue and Yellow, perfect for color coding.

MODEL NO.	OUTSIDE DIMENSIONS L" x W" x H"	CTN QTY	CTN WGT
QTB405	5-1/4" x 4-3/4" x 6-1/4"	5	6 lbs
QTB406	3-5/8" x 4-1/16" x 4-1/4"	6	4 lbs
QTB409	2-3/8" x 2-13/16" x 3"	9	3 lbs



TBC-32WT

32 Compartment Tip Out Bin Cart

19-1/2"L x 25"W x 41"H. Comes complete with one 5-bin, two 4-bin units and one 3-bin unit on each side. Comes fully assembled, ready to use. Available in White.



**Clear Tip Out
Bin Systems
can be used in
any application**



Industrial, Mechanical and Plumbing Supplies

Very handy for the garage, tool shed, service vehicle, factory, hardware and home center facilities.



Medical

Very efficient when it comes to organizing and keeping an effective inventory in hospitals, pharmacies, labs or clinics.



Playroom

The smartest organizer after a hard day's play. It will help keep your child's room in order.

CLEAR TIP OUT BIN RAILS & FRAMES



LOWEST PRICE GUARANTEED!

Clear Tip Out Bin Rails

Provide an easy and efficient way to build a high density expandable storage system. U-channel shaped rails allow Tip Out Bins to slide easily to any height. Each Tip Out Bin needs 2 disks and 2 screws (QDS300) in order to affix to all rails and frames. (Bins are sold separately)



Utilize rails when base of the first bin will sit on the floor

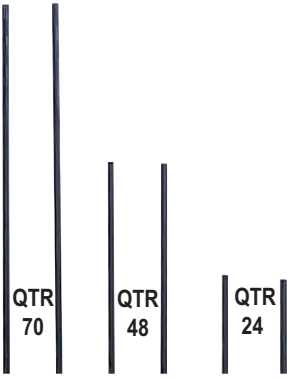

NO. OF BINS TO FIT EACH FRAME

MODEL NO.	DESCRIPTION	CTN QTY	CTN WGT	QTB 302	QTB 303	QTB 304	QTB 305	QTB 306	QTB 309
QTR24	Two 24"H Rails	1 Set	2 lbs	1	2	3	3	5	8
QTR48	Two 48"H Rails	1 Set	4 lbs	3	5	6	7	10	16
QTR70	Two 70"H Rails	1 Set	5 lbs	5	7	8	10	15	23

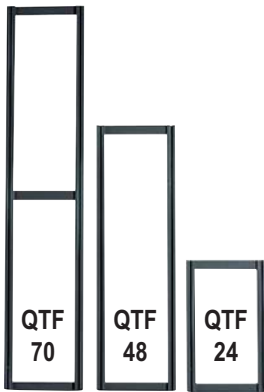

Utilize frame when bins will be mounted above floor level

TIP OUT BIN

Clear Tip Out Bin Frames

Frames are manufactured with preset parallel distance allowing Tip Out Bins to be stacked and removed easily and efficiently. All frames have a ledge at the bottom allowing Tip Out Bins to be secured above ground level. (Bins are sold separately)

NO. OF BINS TO FIT EACH FRAME

MODEL NO.	DESCRIPTION	CTN QTY	CTN WGT	QTB 302	QTB 303	QTB 304	QTB 305	QTB 306	QTB 309
QTF24	24"H Frame	1	3 lbs	1	2	3	3	5	8
QTF48	48"H Frame	1	5 lbs	3	5	6	7	10	16
QTF70	70"H Frame	1	7 lbs	5	7	8	10	15	23



QTF320-42 Complete Unit

QLR500 Locking Rod
Keeps bins from tilting open



QTF320 Portable Frame
(Bins Sold Separately)

MODEL NO.	DESCRIPTION	CTN QTY	CTN WGT
QTF320	24"W x 15"H Portable Frame Only	1	3 lbs
QDS300*	2 Disks and 2 Screws	1 Set	1 lb
QLR500	Locking Rod	1	1 lb
QTF320-42	Complete Frame Unit with Bins	1	20 lbs

*In order to attach a Tip Out Bin unit to a rail, frame or floor stand, 1 set of disks and screws are required per Tip Out Bin.

How Tip Out Bins affix to rails and frames



1. Having removed transparent compartments, insert screw corresponding to screw holes in Tip Out Bin housing.



2. Insert screws and screw into disk on back of Tip Out Bin housing.



3. Insert disk into frame rails.



4. Once in place, tighten screws to affix Tip Out Bin to frame rails.

FREE STANDING & GONDOLA SLIDER SYSTEMS

Free Standing Slider Systems - Complete Packages

This system features four individual panels filled with tip out bins. Two are fixed to the back side of the system and two slide easily from left to right allowing free access to all four panels. Manufactured of tough 14 gauge steel with a baked enamel finish, the overall unit measures 18"D x 48"W x 77"H. (96" widths and 26" depths are available via special order). Bins are available in White, Ivory and Gray.



QS-BIG-101
26"D x 51-1/4"W x 77"H

**TIP OUT
BIN**

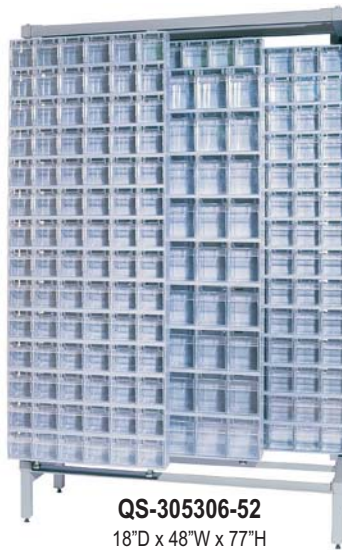

QS-305306-52
18"D x 48"W x 77"H



QS-569-56
18"D x 48"W x 77"H

MODEL NO.	NO. OF BINS	NO. OF BIN CUPS
QS-304-28	28 QTB304	112
QS-305-36	36 QTB305	180
QS-306-56	56 QTB306	336
QS-309-80	80 QTB309	720
QS-305306-52	9 QTB305, 43 QTB306	303
QS-569-56	8 QTB305, 36 QTB306, 12 QTB309	364
QS-BIG-101	3 QTB302, 8 QTB303, 14 QTB304, 3 QTB305	101
QS-000	Free Stand Slider Only - NO BINS	

All necessary hardware included with all units

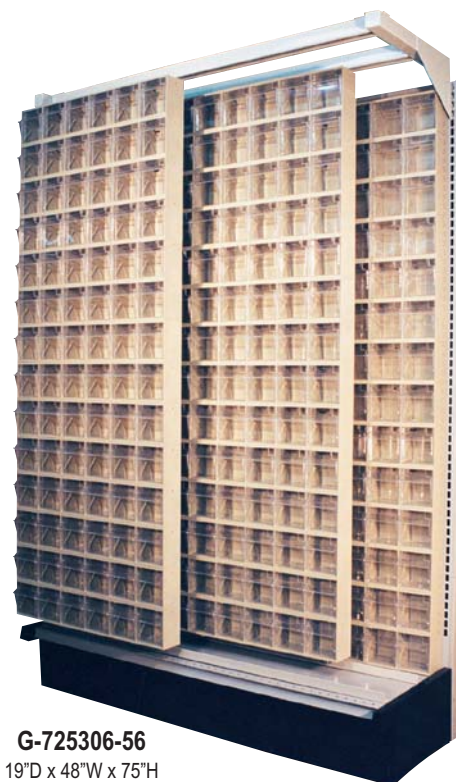

G-725306-56
19"D x 48"W x 75"H

Gondola Slider Systems - Complete Packages

The Gondola system provides the same versatility for orderly and efficient storage solutions in merchandising, inventory control and storing of small to medium sized parts. Slider system affixes to most standard gondolas.

Units available for purchase in the following three ways:

- Slider Frame Only (designed for fast installation on your existing 72"H Gondola). Model No.: QS-725
- Slider Frame with Gondola (no Tip Out Bins) Overall Dimensions 19"D x 48"W x 75"H. Model No.: G-725
- Slider Frame filled with Tip Out Bins with Gondola (five available combinations, see chart below).

Bins are available in White, Ivory and Gray.

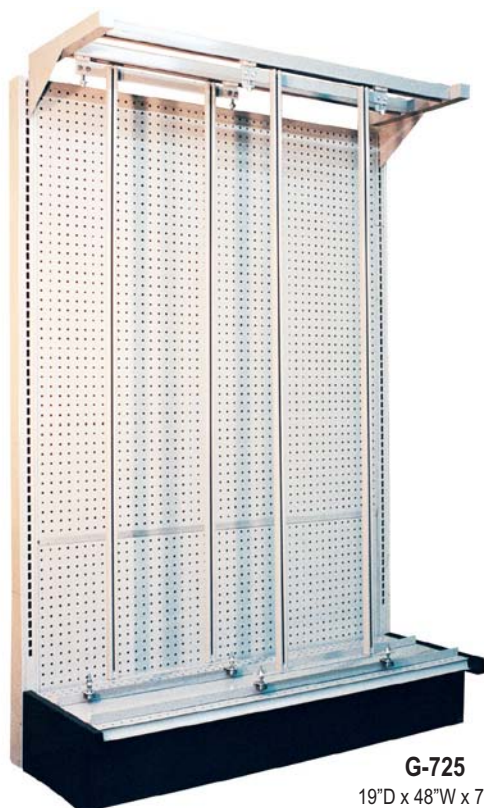

G-725
19"D x 48"W x 75"H

**LOWEST
PRICE
GUARANTEED!**

MODEL NO.	NO. OF BINS	NO. OF BIN CUPS
QS-725	Slider Frame Only	
G-725	Slider Frame With Gondola	
G-725304-28	28 QTB304	112
G-725305-36	36 QTB305	180
G-725306-56	56 QTB306	336
G-725309-80	80 QTB309	720
G-725569-56	8 QTB305, 36 QTB306, 12 QTB309	364

All necessary hardware included with all units

SINGLE & DOUBLE SIDED CLEAR TIP OUT BIN STANDS

Clear Tip Out Bin Floor Stands Single, Double and Mobile

9 preconfigured units available as pictured allowing you to purchase your Tip Out unit exactly as shown here. The flexibility of the system also allows you to customize and create your own configurations (see chart for all possibilities). All steel units are formed from heavy-duty 14 gauge steel and have a smooth powder coat finish ensuring years of use. Three different heights to choose from: 24", 48" or 70". Units are single sided, double sided or double sided mobile. Tip Out Bins are available in Ivory, White or Gray. See page 58 for bin dimensions.

COMPLETE PACKAGES with Tip Out Bins!

Create your own configuration

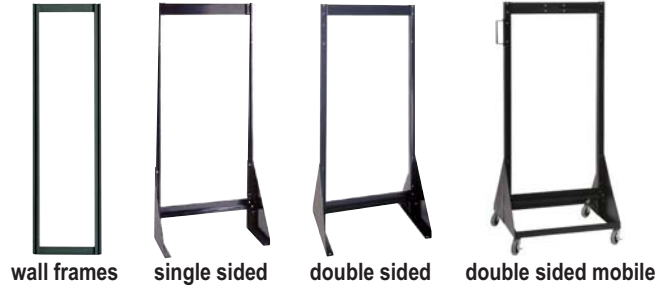

Fastest
Shipping
IN THE INDUSTRY



QFS170-36
4 QTB303
2 QTB304
2 QTB305
1 QTB306



QFS148-38
1 QTB302
1 QTB303
1 QTB304
1 QTB305
1 QTB306
2 QTB309



QFS270-72
8 QTB303
4 QTB304
4 QTB305
2 QTB306



QFS248-76
2 QTB302
2 QTB303
2 QTB304
2 QTB305
2 QTB306
4 QTB309



QFS124-31
1 QTB304
3 QTB306
1 QTB309



QFS224-24
2 QTB303
2 QTB304
2 QTB305

**LOWEST
PRICE
GUARANTEED!**

**TIP OUT
BIN**

MOBILE CLEAR TIP OUT BIN STANDS

COMPLETE PACKAGES with Tip Out Bins!

**TIP OUT
BIN**



QFS270-72 + QFS400

- 8 QTB303
- 4 QTB304
- 4 QTB305
- 2 QTB306



QFS224-24 + QFS400

- 2 QTB303
- 2 QTB304
- 2 QTB305



QFS248-76 + QFS400

- 2 QTB302
- 2 QTB303
- 2 QTB304
- 2 QTB305
- 2 QTB306
- 4 QTB309



**LOWEST
PRICE
GUARANTEED!**

QTY. OF BINS TO FIT UNIT

MODEL NO.	DESCRIPTION	DIMENSIONS D" x W" x H"	CTN WGT	QTB 302	QTB 303	QTB 304	QTB 305	QTB 306	QTB 309
Floor Stands - Single Sided (Disks and Screws Required)									
QFS124	24"H Single Sided (Workstation)	8" x 23-5/8" x 28"	11 lbs	1	2	3	3	5	8
QFS148	48"H Single Sided	8" x 23-5/8" x 52"	19 lbs	3	5	6	7	11	16
QFS170	70"H Single Sided	8" x 23-5/8" x 75"	20 lbs	5	7	8	10	15	23
Floor Stands - Double Sided (Disks and Screws Required)									
QFS224	24"H Double Sided (Workstation)	16" x 23-5/8" x 28"	21 lbs	2	4	6	6	10	16
QFS248	48"H Double Sided	16" x 23-5/8" x 52"	36 lbs	6	10	12	14	22	32
QFS270	70"H Double Sided	16" x 23-5/8" x 75"	42 lbs	10	14	16	20	30	46
Mobile Kit (Includes four casters and one handle)									
QFS400	Mobile Kit for Double Sided Units		9 lbs	-	-	-	-	-	-
Disks and Screws									
QDS300	2 Disks and 2 Screws (1 set)		1 lb	-	-	-	-	-	-

Tip Out Bins Sold Separately. 1 set of disks and screws are required per Tip Out Bin.

INTERLOCKING STORAGE CABINETS



Interlocking Storage Cabinets

Organize and store your small parts with these modular storage cabinets. Quantum's interlocking storage cabinets have the unique ability to interlock horizontally and vertically allowing you to customize your storage needs. Pre-drilled holes on the backside of cabinet allow for wall mounting. Cabinets are made from high impact polystyrene. Drawers are removable and will not rust or corrode. Drawers have a recessed handle and come with a slotted label holder. Drawers have seven divider slots molded in so that it may be divided into multiple compartments. Clear window allows easy identification of parts. Nine preconfigured Interlocking Storage Cabinet Units come complete with drawers, clear windows and two dividers per drawer. Additional dividers may be purchased separately. Cabinets are available in Gray only. Drawers are available in Gray, Blue, Red and Ivory. Please specify.



Cabinets have the unique ability to interlock horizontally and vertically allowing you to customize your storage needs.



QIC-161

QIC-161

Overall Dimensions 11-3/8"D x 11-3/4"W x 11"H
Unit comes with 16 IDR 201.
Available with Gray Cabinet and your choice of Gray, Blue, Red and Ivory for drawers.



**LOWEST
PRICE
GUARANTEED!**



MODEL NO.	DRAWERS PER CABINET	CTN QTY	CTN WGT
QIC-161	16 IDR201	1	10 lbs
QIC-122	12 IDR202	1	10 lbs
QIC-83	8 IDR203	1	9 lbs
QIC-64	6 IDR204	1	9 lbs
QIC-8143	8 IDR201, 4 IDR203	1	10 lbs
QIC-12123	12 IDR201, 2 IDR203	1	10 lbs
QIC-4163	4 IDR201, 6 IDR203	1	10 lbs
QIC-8224	8 IDR202, 2 IDR204	1	10 lbs
QIC-4244	4 IDR202, 4 IDR204	1	10 lbs



QIC-122



QIC-83



QIC-64



QIC-8143



QIC-12123



QIC-4163



QIC-8224



QIC-4244

Color code your small parts!



Cabinet Drawers

Additional Drawers may be purchased separately. All drawers come complete with a clear window. Optional dividers may be purchased separately. Available in Gray, Blue, Red and Ivory. Please specify color.

MODEL NO.	DIMENSIONS L" x W" x H"	CTN QTY	CTN WGT	DIVIDER	CTN QTY	CTN WGT
IDR201	11" x 2-3/4" x 2-1/2"	24	9 lbs	DIV201	25	1 lb
IDR202	11" x 2-3/4" x 3-5/16"	24	12 lbs	DIV202	25	1 lb
IDR203	11" x 5-5/8" x 2-1/2"	24	14 lbs	DIV203	25	1 lb
IDR204	11" x 5-5/8" x 3-5/16"	24	22 lbs	DIV204	25	2 lbs

INTERLOCKING STORAGE CABINET FLOOR STANDS

Interlocking Storage Cabinet Floor Stands Single, Double and Mobile

24 pre-configured units provide an assortment of storage solutions to meet every need. All steel units are formed from heavy-duty 14 gauge steel and have a smooth powder coat finish ensuring years of use. Three different heights to choose from: 24", 48" or 70". Units are single sided or double sided. Double-sided units can be made mobile with the addition of the QFS-400 (mobile kit). All single sided and double sided units must be securely fastened to the floor to ensure stability. Interlocking Storage Cabinet Units come complete with drawers, clear windows and two dividers per drawer. Exterior Cabinets are available in Gray only. Drawers are available in Gray, Blue, Red and Ivory.

Fastest
Shipping
IN THE INDUSTRY

**High Density
Storage!**

**LOWEST
PRICE
GUARANTEED!**

**COMPLETE
PACKAGES
with bins!**



QIC-124-83



QIC-248-122 + QFS-400



QIC-270-161

COMPLETE STORAGE CABINET FLOOR STANDS							
SINGLE SIDED UNIT				DOUBLE SIDED UNIT			
MODEL NO.	CABINET PER FLOOR STAND	NO. OF DRAWERS	SHIP WGT	MODEL NO.	CABINET PER FLOOR STAND	NO. OF DRAWERS	SHIP WGT
24"H Single Sided Unit				24"H Double Sided Unit			
QIC-124-161	4 QIC-161	64	52 lbs	QIC-224-161	8 QIC-161	128	102 lbs
QIC-124-122	4 QIC-122	48	52 lbs	QIC-224-122	8 QIC-122	96	102 lbs
QIC-124-83	4 QIC-83	32	48 lbs	QIC-224-83	8 QIC-83	64	94 lbs
QIC-124-64	4 QIC-64	24	48 lbs	QIC-224-64	8 QIC-64	48	94 lbs
48"H Single Sided Unit				48"H Double Sided Unit			
QIC-148-161	8 QIC-161	128	100 lbs	QIC-248-161	16 QIC-161	256	196 lbs
QIC-148-122	8 QIC-122	96	100 lbs	QIC-248-122	16 QIC-122	192	196 lbs
QIC-148-83	8 QIC-83	64	92 lbs	QIC-248-83	16 QIC-83	128	180 lbs
QIC-148-64	8 QIC-64	48	92 lbs	QIC-248-64	16 QIC-64	96	180 lbs
70"H Single Sided Unit				70"H Double Sided Unit			
QIC-170-161	12 QIC-161	192	140 lbs	QIC-270-161	24 QIC-161	384	282 lbs
QIC-170-122	12 QIC-122	144	140 lbs	QIC-270-122	24 QIC-122	288	282 lbs
QIC-170-83	12 QIC-83	96	129 lbs	QIC-270-83	24 QIC-83	192	258 lbs
QIC-170-64	12 QIC-64	72	129 lbs	QIC-270-64	24 QIC-64	144	258 lbs

Cabinets are available in Gray only. Drawers are available in Gray, Blue, Red and Ivory. Please specify.

QFS-400 Kit for mobilizing double sided units. Includes casters and handle.

TOOL STORAGE & ORGANIZERS

Wrench Holder

Versatile wrench holder can be mounted on a wall or can lay flat. Manufactured from high impact Polystyrene industrial-strength plastic and can hold up to 15 wrenches of different sizes. Mounting hardware is not included.

MODEL NO.	OUTSIDE DIMENSIONS L" x W" x H"	CTN QTY	CTN WGT
Wrench Holder			
WH-15	1" x 7-1/8" x 11-5/8"	12	12 lbs
Tool Rack			
TR-96	6" x 24-1/8" x 2-3/4"	12	12 lbs



Tool Rack

Space saving tool rack is manufactured from durable polypropylene. Get organized with this tough rack that will not warp or bend even when it is loaded to capacity. Holds up to 96 items. Mounting hardware is not included.



ORG80032

Single Sided Organizer

- Offers up to 22 storage compartments
- Includes 18 dividers allowing you to customize the size of the desired compartments inside



ORG80322

Double Sided Organizer

- Offers up to 32 storage compartments
- Includes 24 dividers allowing you to customize the size of the desired compartments inside

**OPENS
FROM BOTH
SIDES!**

Organizers

Clear lid design allows quick identification of parts inside. Unique latch design enables lid to close and latch tight and secure.

MODEL NO.	OUTSIDE DIMENSIONS L" x W" x H"	CTN QTY	CTN WGT
ORG80032	13" x 10" x 2"	6	7 lbs
ORG80322	13" x 10" x 3"	5	9 lbs

Fastest
Shipping
IN THE INDUSTRY

Divided Small Item Storage Box

Utility box offers 10 compartments for small and medium parts storage. Manufactured of clear, see-through polypropylene.

MODEL NO.	OUTSIDE DIMENSIONS L" x W" x H"	CTN QTY	CTN WGT
QB900	10-1/4" x 13" x 2-3/8"	6	8 lbs



QB900



Deep compartments are ideal for automotive parts, hardware or cleaning supplies

Industrial-strength polypropylene

Tool Caddy

Industrial strength, hand-held caddy ideal for tools and supplies. This portable, high density polypropylene caddy has extra strength ribs for support. Deep compartments make transporting tools, supplies and loose parts easy. Available in Gray and Blue. 6 per carton.

MODEL NO.	OUTSIDE DIMENSIONS L" x W" x H"	CTN QTY	CTN WGT
TC-500	13-7/8" x 18-3/8" x 9"	6	13 lbs



TC-500

13-7/8" L x 18-3/8" W x 9" H



Comfortable grip handle even when carrying heavy load

Perfect for tools, parts and janitorial supplies!

DOLLIES, COLLAPSABLE & STACKER CONTAINERS

Plastic Dollies

DLY-2415 is 24"L x 15"W with 1" Ledge, available in Black. DLY-3018 is 30"L x 18"W with Padded Rubber Trim, available in Blue. 1,000 lb. load capacity.

MODEL NO.	DESCRIPTION	CTN WGT
DLY-2415	Dolly with 1" Ledge	14 lbs
DLY-3018	Dolly with Padded Rubber Trim	19 lbs
HANDLE-DLY	32" Dolly Pull Rod with Handle	2 lbs

Bins sold separately.

MOBILIZE YOUR BINS!



DLY-2415

Interior Dimensions 24"L x 15"W
Exterior Dimensions 28"L x 18-1/2"W



DLY-3018

Interior Dimensions 22-3/8"L x 16"W
Exterior Dimensions 30"L x 18"W

Attached pull ring allows dolly to be pulled with ease
Padded Rubber Trim provides non-slip grip

LOWEST PRICE GUARANTEED!

Heavy-duty Collapsible Containers

Strong, reliable and reusable Collapsible Containers offer "true form" ergonomic carrying handles, designed for safer lifting. Containers have knock down ratios as high as 5:1, saving space and return freight. Modular to standard AIAG 48" x 45" pallet footprint. Large label and cardholder area provide easy identification and improved inventory control. Available in Gray.



Collapses down to 2-1/2"



Fully Expanded

SPACE SAVING! RETURNABLE! REUSABLE!

MODEL NO.	OUTSIDE DIMENSIONS L" x W" x H"	INSIDE DIMENSIONS L" x W" x H"	CTN QTY	CTN WGT
RC1215-089	15" x 12" x 9"	13-3/8" x 10-1/2" x 8-1/2"	1	4 lbs
RC2415-075	24" x 15" x 7-1/2"	22-1/2" x 13-5/8" x 7"	1	5 lbs
RC2415-089	24" x 15" x 9"	22-1/4" x 13-3/4" x 8-1/2"	1	5 lbs
RC2415-111	24" x 15" x 11"	22-1/2" x 13-1/2" x 10-3/4"	1	6 lbs
RC2415-147	24" x 15" x 15"	22-1/2" x 13-1/2" x 14-3/4"	1	7 lbs

Stackers - Heavy-duty Straight Wall Stacking Container

Heavy-duty, straight wall containers maximize your space when used for shipping, storage or work-in progress. Greater strength and durability provided by reinforced corners allowing this strong container to hold the heaviest of parts! Containers are injection molded from high-density polyethylene. Straight wall design allows for modular stacking of all sizes on standard pallet. Hand grips on two sides make the container easy to handle and carry. Up to 150 lb. stack capacity. Available in Gray.



Smooth, straight wall interior allows for maximum usage

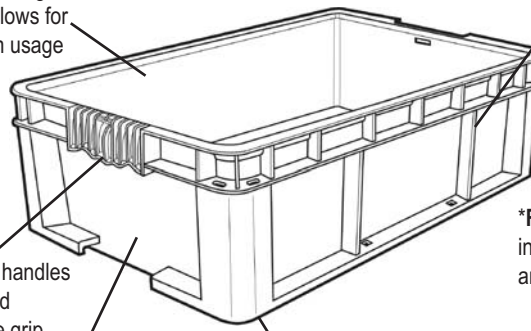

Finger grip handles for easy and comfortable grip

Flat surface ideal for labeling or bar coding parts

Textured bottom ensures non-slip, easy conveyable surface

Reinforced external ribbing and stacking rims provide maximum stacking strength up to 150 lbs.

*RSO1408-7 available in Black only and with an attached lid.



Optional 3" x 5" adhesive clear label holder attaches securely for easy part identification. Model No: QDL-2115 Carton of 24

MODEL NO.	OUTSIDE DIMENSIONS L" x W" x H"	INSIDE DIMENSIONS L" x W" x H"	CTN QTY	VOLUME (CU FT)	CTN WGT	LID
RSO1207-5	12" x 7-1/2" x 5"	9-3/4" x 5-1/2" x 5"	1	0.1	2 lbs	-
RSO1215-5	12" x 15" x 5"	9-1/2" x 13" x 5"	1	0.3	2 lbs	LID1215
RSO1215-7	12" x 15" x 7-1/2"	9-1/2" x 13" x 7"	1	0.5	3 lbs	LID1215
RSO1408-7*	13-3/5" x 6-3/4" x 6-3/4"	11-1/4" x 5-1/2" x 6-1/2"	1	0.2	2 lbs	-
RSO2415-5	24" x 15" x 5"	21-1/2" x 13" x 5"	1	0.7	4 lbs	LID2415
RSO2415-7	24" x 15" x 7-1/2"	21-1/2" x 13" x 7"	1	1.1	5 lbs	LID2415
RSO2415-9	24" x 15" x 9-1/2"	21-1/2" x 13" x 9"	1	1.4	5 lbs	LID2415
RSO2422-11	24" x 22-1/2" x 11"	21-1/2" x 20-1/2" x 10-1/4"	1	3.5	8 lbs	-

Plastic Mobile Dolly

DLY-2415 Dolly with 1" Ledge, available in Black. 1,000 lb. capacity. Interior Dimensions 24"L x 15"W Exterior Dimensions 28"L x 18-1/2"W

MODEL NO.	DESCRIPTION	CTN WGT
DLY-2415	Dolly with 1" Ledge	14 lbs

Bins sold separately.

GENUINE STACK AND NEST TOTES

Lids available for all totes. See chart below for order information.

Totes will nest when empty or can be turned 180° to stack.

3" x 5" clear label holder, ideal for part identification.
Model No: snh 010



All nine sizes of totes have ability to use the optional clear label holder. It securely attaches to tote with or without lid for easy part identification.
Model No.: snh010



PERFORMANCE FEATURES AT A GLANCE:

- Available in 9 sizes
- Standard colors: Gray, Blue and Red
- Totes are injection molded from high density polypropylene material that complies with the USDA and FDA regulations for use in food processing
- stack and nest totes will not rust, corrode, bend out of shape, are unaffected by chemicals and are waterproof
- Reusable container will stack with or without lids for maximum storage and shipping
- snt's have the unique ability to stack and they can be turned 180° to nest when empty saving valuable space
- Textured bottoms ensure safe and easy, non-slip grip in transit on conveyors



Easy to clean smooth surface

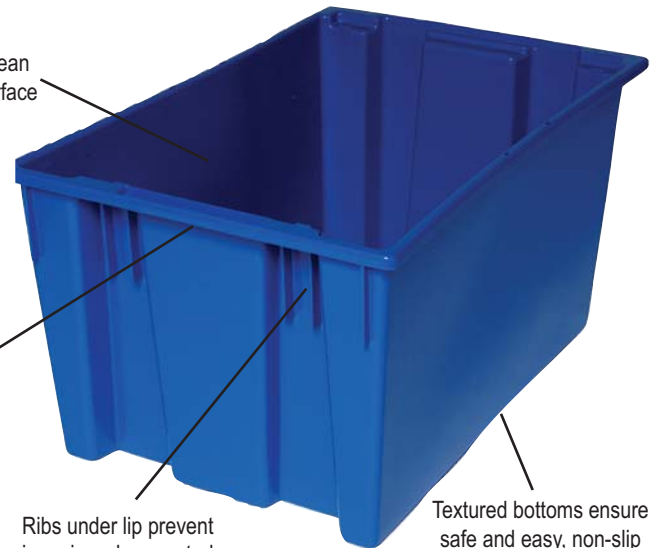

Handle grips on either side for easy carrying and handling

Ribs under lip prevent jamming when nested

Textured bottoms ensure safe and easy, non-slip grip transit on conveyors



snt190

snt185



snt180



DLY-3018
(Bin sold separately)

Attached pull ring allows dolly to be pulled with ease

Plastic Mobile Dolly

DLY-3018 Dolly with Padded Rubber Trim, available in Blue. 1,000 lb. capacity. Interior Dimensions 22-3/8"L x 16"W Exterior Dimensions 30"L x 18"W

MODEL NO.	DESCRIPTION	CTN WGT
DLY-3018	Dolly with Padded Rubber Trim	19 lbs
HANDLE-DLY	32" Dolly Pull Rod with Handle	2 lbs

Bins sold separately.

GENUINE STACK AND NEST TOTES



Optional lid snaps on tightly and securely to protect container contents. As pictured, lids can be fastened and locked for added security.

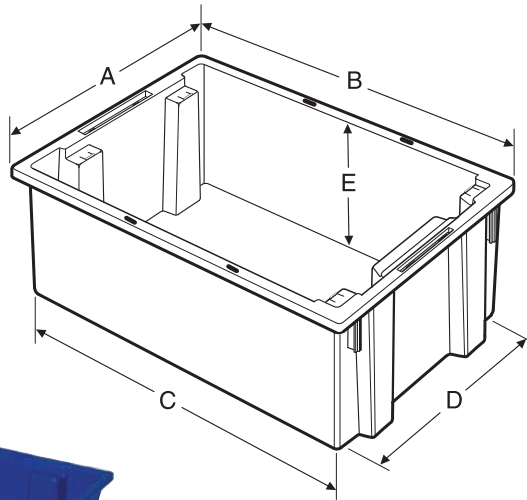

snt225



snt230



snt240



482212DPP



Polymer Dunnage Platform

Ergonomically designed, Polymer Dunnage Platform is ideal to keep items off the ground. This lightweight, structural foam, high density polyethylene platform holds up to 4,000 lbs. and can withstand temperatures from -20° to 212°F. This one piece constructed unit will not rust or corrode, is impervious to mold and mildew, and can be steam cleaned. 10" clearance allows for fast and easy cleaning. NSF Approved. Overall dimensions: 22"W x 48"L x 12"H

MODEL NO.	DIMENSIONS W" x L" x H"	SHIP WGT
482212DPP	22" x 48" x 12"	16 lbs

Bins sold separately.



snt300



Genuine stack and nest totes

These heavy-duty, tough, and dependable stack and nest totes are the ultimate reusable container for storage and transporting your valuable items in any application. These proven containers are available in nine sizes and three colors for efficiency and inventory control. Available in Gray, Blue and Red.

MODEL NO.	OUTSIDE DIMENSIONS			INSIDE DIMENSIONS			CAPACITY (CU FT)	CTN QTY	CTN WGT	LID	CTN QTY
	L" x W" x H"	A	B	C	D	E					
snt180	18" x 11" x 6"	10"	16"	15-1/4"	9-3/8"	5-7/8"	0.50	6	12 lbs	LID181	6
snt185	18" x 11" x 9"	10"	16"	15-1/8"	9-1/8"	8-7/8"	0.76	6	15 lbs	LID181	6
snt190	19-1/2" x 15-1/2" x 10"	14-1/2"	17"	16"	13-1/4"	9-7/8"	1.20	6	23 lbs	LID191	6
snt195	19-1/2" x 15-1/2" x 13"	14-1/2"	17"	15-7/8"	13-3/8"	12-7/8"	1.70	6	26 lbs	LID191	6
snt200	19-1/2" x 13-1/2" x 8"	12-3/8"	17-7/8"	16-3/8"	11-1/2"	7-7/8"	0.80	6	19 lbs	LID201	6
snt225	23-1/2" x 19-1/2" x 10"	18-1/4"	20-7/8"	19-3/8"	16-7/8"	9-7/8"	2.00	3	18 lbs	LID231	3
snt230	23-1/2" x 19-1/2" x 13"	18-1/8"	20-7/8"	19-1/2"	16-7/8"	12-7/8"	2.60	3	22 lbs	LID231	3
snt240	23-1/2" x 15-1/2" x 12"	14-1/4"	20-7/8"	19-5/8"	13"	11-7/8"	1.70	3	18 lbs	LID241	3
snt300	29-1/2" x 19-1/2" x 15"	18-1/4"	26-5/8"	25-1/8"	16-5/8"	14-7/8"	3.70	3	31 lbs	LID301	3
snh010	Clear Label Holder - 3" x 5" (Fits all tote sizes)							6	1 lb	-	-

DIVIDABLE GRID CONTAINERS

Dividable Grid Containers

Heavy duty Dividable Grid Containers can be used in industrial, commercial, electronic and health care industries for storage, assembly, fabrication and distribution applications. These containers offer the safest and most efficient method for compartmentalizing and protecting small to medium sized parts. Dividers allow you to customize the container's interior to meet your exact needs. Containers and covers are available in Blue, Gray and Red. Covers are also available in clear.

Covers are available in Blue, Gray, Red and Clear!

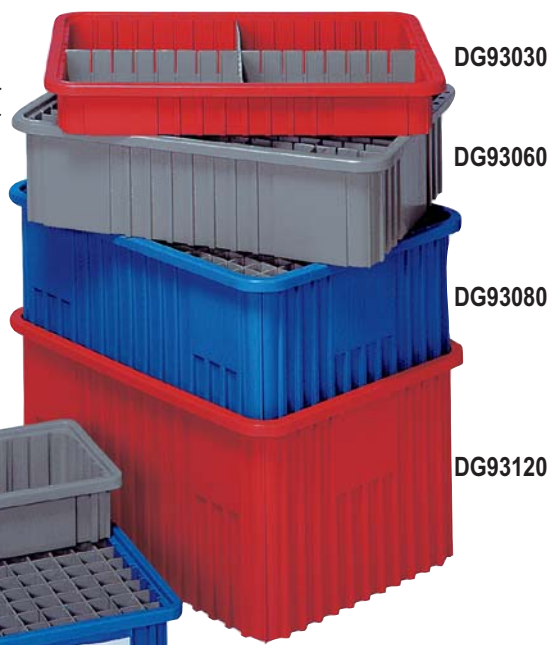

Dividers

Containers can be divided by length and/or width allowing a subdivision down to a 1-1/8" square compartment size. Available in Gray.



Snap On Covers

Snap on covers protect contents from damage or dust during shipping and storage.



Clear Label Holder

Fits any size container. Three sizes to choose from.

DG92080

new



Clear Acrylic Dust Cover Inlays keep stored items visible while protecting against airborne dust and other contaminants. Cover lays inside on rim of container.

DG92060



Available on page 10

Clear Dust Cover Acrylic Inlays

MODEL NO.	FITS BIN MODEL NO.	CTN QTY
DDC91000CL	DG91035, DG91050	10
DDC92000CL	DG92035, DG92060, DG92080	4
DDC93000CL	DG93030, DG93060, DG93080, DG93120	3

Clear Covers

MODEL NO.	FITS BIN MODEL NO.	CTN QTY
COV91000CL	DG91035, DG91050	10
COV92000CL	DG92035, DG92060, DG92080	4
COV93000CL	DG93030, DG93060, DG93080, DG93120	3

Clear Label Holders

MODEL NO.	DIMENSIONS H" x W"	FITS BIN MODEL NO.	CTN WGT
LBL2X8	2" x 8"	DG91035, DG92035, DG93030	6
LBL3X5	3" x 5"	DG91050, DG92060, DG93060	6
LBL5X8	5" x 8"	DG92080, DG93080, DG93120	6



Plastic Mobile Dolly

DLY-3018 Dolly with Padded Rubber Trim, available in Blue. 1,000 lb. capacity. Interior Dimensions 22-3/8"L x 16"W. Exterior Dimensions 30"L x 18"W



DLY-3018

(Bin sold separately)

Attached pull ring allows dolly to be pulled with ease

MODEL NO.	OUTSIDE DIMENSIONS L" x W" x H"	INSIDE DIMENSIONS L" x W" x H"	CTN QTY	CTN WGT	LONG DIVIDER	CTN QTY	SHORT DIVIDER	CTN QTY	COVER	CTN QTY
DG91035	10-7/8" x 8-1/4" x 3-1/2"	9-3/16" x 6-9/16" x 3"	20	24 lbs	DL91035	6	DS91035	6	COV91000	10
DG91050	10-7/8" x 8-1/4" x 5"	9-3/16" x 6-9/16" x 4-1/2"	20	32 lbs	DL91050	6	DS91050	6	COV91000	10
DG92035	16-1/2" x 10-7/8" x 3-1/2"	14-7/8" x 9-1/4" x 3"	12	23 lbs	DL92035	6	DS92035	6	COV92000	4
DG92060	16-1/2" x 10-7/8" x 6"	14-7/8" x 9-1/4" x 5-1/2"	8	20 lbs	DL92060	6	DS92060	6	COV92000	4
DG92080	16-1/2" x 10-7/8" x 8"	14-7/8" x 9-1/4" x 7-1/2"	8	27 lbs	DL92080	6	DS92080	6	COV92000	4
DG93030	22-1/2" x 17-1/2" x 3"	20-5/8" x 15-5/8" x 2-1/2"	6	20 lbs	DL93030	6	DS93030	6	COV93000	3
DG93060	22-1/2" x 17-1/2" x 6"	20-5/8" x 15-5/8" x 5-1/2"	3	19 lbs	DL93060	6	DS93060	6	COV93000	3
DG93080	22-1/2" x 17-1/2" x 8"	20-5/8" x 15-5/8" x 7-1/2"	3	16 lbs	DL93080	6	DS93080	6	COV93000	3
DG93120	22-1/2" x 17-1/2" x 12"	20-5/8" x 15-5/8" x 11-1/2"	3	23 lbs	DL93120	6	DS93120	6	COV93000	3

CROSS STACK TUBS AND QUANTUBS

Cross Stack Tubs

Manufactured of approved USDA/FDA materials, tote nests when empty or can be turned 90° to cross stack. Easy access to items when stacked. Injection molded from durable, high impact polypropylene. Easy to clean. Built in handles and bottom grooves makes handling easy. Holds up to 100 lbs. Six 1/4" drill hole pattern on bottom of bin allow for easy hole insertion for optional air flow and drainage. Available in Gray, Blue and White. 6 per carton.



TUB2516-8
25-1/8"L x 16"W x 8-1/2"H



Tub Racks

All-welded aluminum Tub Rack transports and stores all types of product. Carts come complete and are shipped assembled with bins. Runners allow bins to slide in and out from both sides. Bins available in Gray, Blue and White.

LID2516-8

Optional lid keeps stored items dust free. Tubs can still stack and cross stack with lids in place!

snh010

3" x 5" Clear Label Holder securely attaches to totes and allows for easy part identification. Fits all tub sizes.

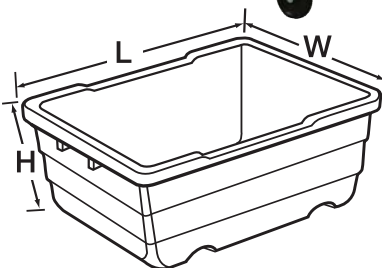

TR4-2516-8
27"L x 19"W x 51"H
Comes with four TUB2516-8



TR6-2516-8
27"L x 19"W x 71"H
Comes with six TUB2516-8



TR3-2516-8
27"L x 19"W x 41"H
Comes with three TUB2516-8



TR1-2516-8
27"L x 19"W x 19"H
Comes with one TUB2516-8

MODEL NO.	OUTSIDE DIMENSIONS L" x W" x H"	CAP GAL	CTN QTY	CTN WGT	LID	CTN QTY
TUB1711-8	17-1/4" x 11" x 8"	3.85	6	14 lbs	LID1711	6
TUB1711-12	17-1/4" x 11" x 12"	5.51	6	17 lbs	LID1711	6
TUB2417-8	23-3/4" x 17-1/4" x 8"	9.81	6	25 lbs	LID2417	6
TUB2417-12	23-3/4" x 17-1/4" x 12"	14.38	6	30 lbs	LID2417	6
TUB2516-8	25-1/8" x 16" x 8-1/2"	9.75	6	20 lbs	LID2516-8	6
SNH010	Six Clear Label Holders - 3" x 5"	14.6	6	1 lb		

QuanTub Nesting Tote

Manufactured of approved USDA/FDA materials, this tote is ideal in food service or dietary department applications. Strong and durable tote is injection molded from high-density polypropylene. Each tote can hold up to 100 lbs. Lightweight and economical tote is easy to clean. Rolled top rim for comfortable grip. Rounded corners add strength to stress points. Totes nest when empty and prevent jamming with rib top. Six 1/4" drill hole pattern on bottom of bin allow for easy hole insertion for optional air flow and drainage. Measures 24-1/2"L x 19"W x 9-1/2"H. Available in Gray and Blue. 6 per carton.



TUB2419-9
24-1/2"L x 19"W x 9-1/2"H

MODEL NO.	OUTSIDE DIMENSIONS L" x W" x H"	CTN QTY	CTN WGT
TUB2419-9	24-1/2" x 19" x 9-1/2"	6	33 lbs

**LOWEST
PRICE
GUARANTEED!**



MODEL NO.	DIMENSIONS L" x W" x H"	NO. OF BINS	SHIP WGT
Tub Rack with Cross Stack Tubs Tub Dimensions 25-1/8"L x 16"W x 8-1/2"H			
TR1-2516-8	27" x 19" x 19"	1	13 lbs
TR2-2516-8	27" x 19" x 31"	2	25 lbs
TR3-2516-8	27" x 19" x 41"	3	33 lbs
TR4-2516-8	27" x 19" x 51"	4	46 lbs
TR5-2516-8	27" x 19" x 61"	5	54 lbs
TR6-2516-8	27" x 19" x 71"	6	58 lbs

WIRE SHELVING SYSTEMS

COMPLETE PACKAGES with bins!

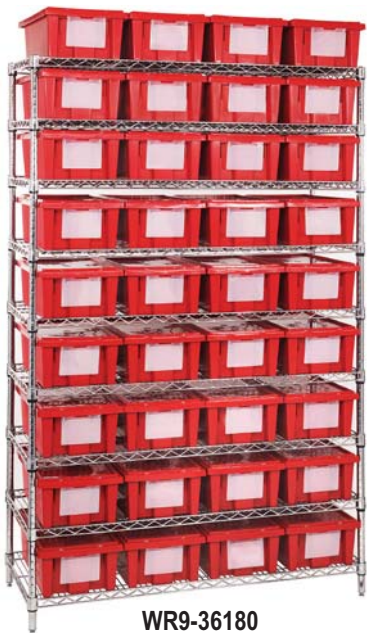

WR9-36180

Shown with optional lids and label holders (Sold separately)

Chrome Wire Shelving System with Genuine stack and nest Totes - Complete Packages

Offering a whopping 800 lb. capacity per shelf, this chrome wire shelving unit with totes is a must have for archival storage, heavy-duty parts organization or inventory control applications. With three packages to choose from offering three colors choices for the bins, this unit can be used just about anywhere! Unit may be made mobile with the addition of the WR-00H mobile kit. See catalog page 69 for additional information and to order optional accessories.

MODEL NO.	NO. OF SHELVES	NO. OF BINS	BIN DIMENSIONS L" x W" x H"	SHIP WGT
18" x 48" x 74" Wire Shelving Unit With stack and nest totes Available in Gray, Blue and Red				
WR9-36180	9	36 snt180	18" x 11" x 6"	178 lbs
WR6-24185	6	24 snt185	18" x 11" x 9"	136 lbs
24" x 66" x 63" Wire Shelving Unit With stack and nest totes Available in Gray, Blue and Red				
WR4-12225	4	12 snt225	23-1/2" x 19-1/2" x 10"	170 lbs

MOBILIZE YOUR WIRE SHELVING

DB - Donut Bumper

Non-marking donut bumper used to protect walls and help cushion impact.



WR-00H (Mobile Kit)*

Set of four swivel polyurethane 5" x 1-1/4" casters, two with brakes. Can be used with all units shown. 1,200 lb. load capacity.

*Mobile kits recommended only for shelves 18" and wider

Chrome Wire Shelving System with Dividable Grid Containers - Complete Packages

Same durable chrome wire shelving combined with Quantum's Dividable Grid Containers. These containers allow for multiple compartment configurations within each bin. Offering four different packages, these systems are ideal for small, medium and large parts storage. Unit may be made mobile with the addition of the WR-00H mobile kit. See catalog page 70 for additional information and to order optional accessories.

MODEL NO.	NO. OF SHELVES	NO. OF BINS	BIN DIMENSIONS L" x W" x H"	SHIP WGT
18" x 48" x 74" Wire Shelving Unit With Dividable Grid Containers Available in Gray, Blue and Red				
WR9-92060	9	36 DG92060	16-1/2" x 10-7/8" x 6"	210 lbs
WR7-92080	7	24 DG92080	16-1/2" x 10-7/8" x 8"	174 lbs
24" x 60" x 63" Wire Shelving Unit With Dividable Grid Containers Available in Gray, Blue and Red				
WR12-93030	12	36 DG93030	22-1/2" x 17-1/2" x 3"	274 lbs
24" x 60" x 74" Wire Shelving Unit With Dividable Grid Containers Available in Gray, Blue and Red				
WR9-93060	9	24 DG93060	22-1/2" x 17-1/2" x 6"	254 lbs

CLEAR new **VIEW** TUBS
Available on page 10

Fastest Shipping IN THE INDUSTRY

LOWEST PRICE GUARANTEED!



WR7-92080

Chrome Mobile Wire Shelving Systems with Cross Stack Tubs & Quantub Nesting Tote - Complete Packages

These unique packages provide a storage solution for large, bulky items. These heavy-duty tubs provide easy access to stored parts for assembly areas, picking stations or inventory control. With three packages to choose from, these strong durable totes provide a durable solution for most applications. See catalog page 71 for more information.

MODEL NO.	NO. OF SHELVES	NO. OF BINS	BIN DIMENSIONS L" x W" x H"	SHIP WGT
24" x 60" x 69" Mobile, Wire Shelving Unit With QuanTub Totes Available in Gray and Blue				
MWR4-2419-9	4	12 TUB2419-9	24-1/2" x 19" x 9-1/2"	175 lbs
18" x 36" x 69" Mobile, Wire Shelving Unit With Cross Stack Tubs Available in Gray, Blue and White				
MWR7-1711-8	7	24 TUB1711-8	17-1/4" x 11" x 8"	151 lbs
MWR5-1711-12	5	15 TUB1711-12	17-1/4" x 11" x 12"	118 lbs



MWR4-2419-9

ATTACHED TOP CONTAINERS



Distribution container has an optional 3" x 5" adhesive clear label holder which attaches securely for easy part identification. 24 per carton.
Model No.: QDL-2115

9 SIZES AVAILABLE!



**STRONG! RELIABLE!
 REUSABLE TOTES!**

HOT STAMPING

AVAILABLE

Call for details.



DLY-2415
 (Bins sold separately)

Plastic Mobile Dolly

DLY-2415 Dolly with 1" Ledge, available in Black.
 1,000 lb. capacity.
 Interior Dimensions 24"L x 15"W
 Exterior Dimensions 28"L x 18-1/2"W

MODEL NO.	DESCRIPTION	CTN WGT
DLY-2415	Dolly with 1" Ledge	14 lbs

Bins sold separately.



Padlock eye provides security option allowing lids to be fastened and/or locked



CUSTOM COLORS AVAILABLE

LOWEST PRICE GUARANTEED!

Heavy-duty Attached Top Containers - Perfect for distribution and off-premises supply centers!

Strong, reliable and reusable totes are ideal for storage, distribution and order picking. Tops are permanently attached with steel hinges that interlock for stacking strength and security. Stack for maximized storage and nest when empty. Textured, non-slip bottom ensures smooth conveying. Ergonomically designed handles allow for easy lifting. Recessed lids ensure maximum load stability. Padlock eye provides security option allowing lids to be fastened and/or locked. Molded from high density, FDA approved polyethylene. Lids close securely to protect parts from dust or damage. Available in Gray.

MODEL NO.	OUTSIDE DIMENSIONS				INSIDE DIMENSIONS				CONTAINER HEIGHT	VOLUME (CU FT)	CAPACITY GAL	STACK CAP/ QTY STACKED	CTN WGT
	TOP L" x W"	BOTTOM L" x W"	TOP L" x W"	BOTTOM L" x W"									
QDC2012-7	20" 11-1/2"	18" 10"	17-3/4" 10-3/4"	17" 9-3/4"	7-1/2"	0.50	8.75	45 lbs / 7	4 lbs				
QDC2115-9	21-1/2" 15-1/4"	19-1/4" 13-1/4"	20-1/4" 14-1/4"	19" 13"	9-5/8"	1.27	9.50	65 lbs / 5	6 lbs				
QDC2115-12	21-1/2" 15-1/4"	19-1/4" 13-1/4"	20-1/4" 14-1/4"	19" 13"	12-3/4"	1.67	12.50	75 lbs / 5	7 lbs				
QDC2115-17	21-1/2" 15-1/4"	19-1/4" 13-1/4"	20-1/4" 14-1/4"	19" 13"	17-1/4"	2.31	17.25	100 lbs / 3	8 lbs				
QDC2213-12	22-1/8" 12-13/16"	19" 10-7/8"	19-7/8" 12"	18-1/2" 10-5/8"	11-7/8"	1.42	12.25	75 lbs / 5	6 lbs				
QDC2420-12	24" 20"	21-1/4" 17-1/4"	22-3/4" 18-1/2"	21" 17"	12-1/2"	2.44	18.25	85 lbs / 5	8 lbs				
QDC2717-12	27" 17-3/4"	24-1/4" 16-3/4"	25-3/4" 16"	24" 14-1/2"	12-1/2"	2.50	18.75	100 lbs / 4	8 lbs				
QDC2515-14	24" 15"	21-1/4" 12-3/4"	22-1/2" 14"	20-3/4" 12-1/4"	13-3/4"	2.20	16.50	100 lbs / 4	8 lbs				
QDC2820-15	28" 20-5/8"	25-7/8" 18-3/4"	26" 19"	25" 18"	15-5/8"	4.00	29.92	100 lbs / 4	13 lbs				

NEW! COLLAPSABLE BULK BOX

Collapsible Bulk Box

Quantum's new collapsible bulk box provides a practical approach to large volume or large part material handling, storage and transport. Used for heavy loads, components and even food products, these reusable and returnable containers allow you to ship, handle, pick, store and distribute your products while increasing productivity and profitability. Quantum's collapsible bulk box comes in a standard pallet size footprint measuring 48"L x 45"W. It can be collapsed down to a fraction of its full height in seconds. Bulk containers stack perfectly loaded or when folded down to minimize storage space. They are designed to make the shipping of your products faster, safer and less costly while providing greater protection. Two access drop doors are able to lie flush against the container allowing easy loading and unloading. Manufactured from High Density Polyethylene, this tough container provides superior protection for products while being stored or in transit. Welded base provides greater strength while the reinforced fork openings provide easy lifting. Can withstand temperatures between -20° and 250°F. Available in Black.

new



QBB-4845-34

**HANDLE. SHIP.
DISTRIBUTE. REUSE.**



Fully opened Bulk Box measures 48"L x 45"W x 34"H



Two access drop doors allows easy loading and unloading



Easy opening and collapsing of Bulk Box's side walls



Collapses to a fraction of its full height



Performance Features:

- Plastic, ergonomic latches for opening and collapsing
- Superior strength with low tare weight
- High return ratio: return 3 collapsed boxes for each bulk box distributed
- 1,800 lb. load capacity for standard usage
- Large, flat labeling area on all four sides

Collapsible Bulk Box

Specifications

MODEL NO. QBB-4845-34	L (inch/mm)	W (inch/mm)	H (inch/mm)
External	48.00/1219.2	45.00/1143.0	33.9/861.1
Internal	44.50/1130.3	41.50/1054.1	28.2/716.0
Usable interior height (fill line)			27.10/688.3
Access drop door - cut out		30.00/762.0	15.95/405.1
Collapsed height			12.76/324.0
Nested height			11.77/299.0
Stack of 9/ collapsed (trailer)			106.93/2716.1
Fork tunnel - 48" side		11.00/279.4	3.40/86.4
Fork tunnel - 45" side		11.38/288.9	3.40/86.4
Ship wgt. - 118 lbs			

POLYMER MOBILE CARTS



PC4026-33
40"L x 26"W x 32-1/2"H

Fastest
Shipping
IN THE INDUSTRY

LOWEST
PRICE
GUARANTEED!

NEW FLAT
top design



PFTC4026-33-3
40"L x 26"W x 32-1/2"H



PFTC4026-33
40"L x 26"W x 32-1/2"H

RUGGED. HEAVY-DUTY.
DURABLE.



PC4026-33-3
40"L x 26"W x 32-1/2"H



PC3518-33-3
34-1/4"L x 17-1/2"W x 32-1/2"H



PC3518-33 + PCTH
34-1/4"L x 17-1/2"W x 32-1/2"H
(Shown with optional Tool Holder Accessory)
Tools not included

Polymer Mobile Carts

Industrial strength cart is ideal for many industrial and commercial material handling applications. Set of 2 swivel and 2 rigid 5" x 1-1/4" heavy-duty casters allow for 550 lb. load capacity. Available in two sizes with a 2 or 3 shelf combination. Available in Gray.

MODEL NO.	OUTSIDE DIMENSIONS L" x W" x H"	INSIDE SHELF DIMENSIONS L" x W"	NO. OF SHELVES	SHIP WGT
PC3518-33	34-1/4" x 17-1/2" x 32-1/2"	29-1/4" x 15-1/4"	2	38 lbs
PC3518-33-3	34-1/4" x 17-1/2" x 32-1/2"	29-1/4" x 15-1/4"	3	51 lbs
PC4026-33	40" x 26" x 32-1/2"	35" x 23"	2	54 lbs
PC4026-33-3	40" x 26" x 32-1/2"	35" x 23"	3	74 lbs
NEW! Polymer Flat Top Shelf Cart				
PFTC4026-33-2	40" x 26" x 32-1/2"	35" x 23"	2	51 lbs
PFTC4026-33-3	40" x 26" x 32-1/2"	35" x 23"	3	71 lbs
Additional Shelves				
PC3518SHELF	34-1/4" x 17-1/2" x 32-1/2"	29-1/4" x 15-1/4"	1	13 lbs
PC4026SHELF	40" x 26" x 32-1/2"	35" x 23"	1	20 lbs

CARTS OFFER
550 lb.
Load Capacity!

Polymer Cart Tool Holder **PATENT PENDING**

MODEL NO.	DESCRIPTION	SHIP WGT
PCTH	96 Piece Tool Holder	3 lbs

NEW! BIN TRANSPORT & SLOPED SHELF TRUCKS



MTT-1842-543

new



MTT-1878-543



MTT-3060-743

NEW! MAGNUM Bin Transport Trucks

All welded construction with 1-1/2" x 3/16" thick angle frame construction. Twin 1-1/4" tubular handles with smooth radius bend. Bolt on urethane casters, 2 swivel & 2 rigid, for easy replacement and superior tracking. Bins available in Blue, Yellow, Green, Red and Black.

MODEL NO.	DIMENSIONS D" x W" x H"	NO. OF BINS	BIN DIMENSIONS L" x W" x H"	SHIP WGT
5" x 1-1/4" Polyurethane Casters, 1,200 lb. Load Capacity				
MTT-1842-543	18" x 42" x 47"	6	19-3/4" x 18-3/8" x 11-7/8"	204 lbs
MTT-3042-743	30" x 42" x 47"	6	29" x 18-3/8" x 11-7/8"	238 lbs
5" x 2" Polyurethane Casters, 3,000 lb. Load Capacity				
MTT-1860-543	18" x 60" x 47"	9	19-3/4" x 18-3/8" x 11-7/8"	256 lbs
MTT-3060-743	30" x 60" x 47"	9	29" x 18-3/8" x 11-7/8"	290 lbs
MTT-1878-543	18" x 78" x 47"	12	19-3/4" x 18-3/8" x 11-7/8"	332 lbs
MTT-3078-743	30" x 78" x 47"	12	29" x 18-3/8" x 11-7/8"	380 lbs



NEW! Sloped Shelf Truck & Stand

All welded construction with 1-1/2" tubular center uprights with 3" x 3/16" thick horizontal construction. Stationary unit includes 5"H legs which allow unit to be moved with fork lift. Mobile units includes bolt on 6" urethane casters, 2 swivel and 2 rigid.

MODEL NO.	DIMENSIONS D" x W" x H"	NO. OF BINS	BIN DIMENSIONS L" x W" x H"	SHIP WGT
Stationary, 12 Sloped Shelf Stand				
SSB-S3036-230240	30" x 36" x 64"	60	10-7/8" x 5-1/2" x 5"	418 lbs
SSB-S3036	30" x 36" x 64"	-	-	360 lbs
Mobile, 12 Sloped Shelf Cart				
MSSB-C3036-230240	30" x 36" x 66"	60	10-7/8" x 5-1/2" x 5"	453 lbs
MSSB-C3036	30" x 36" x 66"	-	-	395 lbs



SSB-S3036-230240



MSSB-C3036-230240

NEW! REMOVABLE TRAY TRUCKS

NEW! Single and Double Sided Removable Tray Trucks

All welded construction with 1-1/2" square tubular frame. Slotted 12 gauge channel uprights (slots on 3-1/2" centers). Bolt on casters, 2 swivel and 2 rigid, for ease of replacement and superior cart tracking. Open and closed front trays and tray dividers sold separately.

MOBILE FRAMES

MODEL NO.	DIMENSIONS W" x L" x H"	SHIP WGT
Single Sided Mobile Frame		
TTS-18	18" x 38" x 67"	170
TTS-24	24" x 38" x 67"	174
Double Sided Mobile Frame		
TTD-30	30" x 38" x 67"	178
TTD-40	40" x 38" x 67"	184

REMOVABLE TRAYS

MODEL NO.	DIMENSIONS D" x W" x H"	SHIP WGT	TRAY DIVIDER MODEL NO.	QUANTITY OF TRAYS TO FIT MOBILE FRAMES			
				FRAME TTS-18	FRAME TTS-24	FRAME TTD-30	FRAME TTD-40
Open Front Trays							
TT-OT9	9" x 36" x 3"	16	TT-DIV3	14	14	28	28
TT-OT15	15" x 36" x 6"	28	TT-DIV6	-	7	-	14
Closed Front Trays							
TT-CT9	9" x 36" x 3"	16	TT-DIV3	14	14	28	28
TT-CT15	15" x 36" x 6"	28	TT-DIV6	-	7	-	14



TTS-24
Single Sided Mobile Frame



**LOWEST
PRICE
GUARANTEED!**

Order this exact unit
TTD-OT15-240
Unit consists of:
1 - double sided frame TTD-40
10 - open front trays TT-OT15
40 - bins QUS240



TTD-40
Double Sided Mobile Frame
Shown with (10) TT-CT15
(Sold separately)



Open Tray
Model No.: TT-OT15



Closed Tray
Model No.: TT-CT15

TRUCKS OFFER
2,000 lb.
Load Capacity!

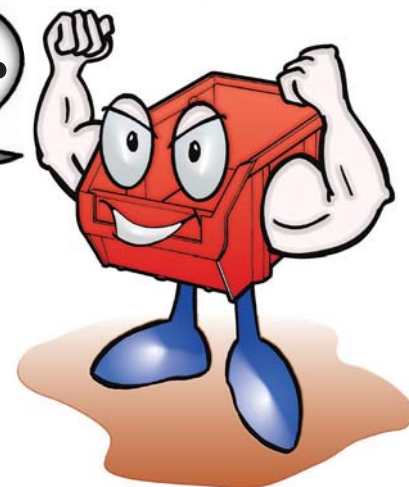

IRONMAN 18 & 20 GAUGE STEEL OPEN SHELVING

IRONMAN

18 & 20 Gauge Steel Open Clip Shelving

- Starter Units

Quantum's IRONMAN Open Shelving Units are ideal for industrial and commercial storage and organization. Easy access to product, high visibility and air flow from all sides. Units are available in 18 & 20 gauge, 4 heights and 15 shelf sizes. Each starter kit includes 4 offset posts (punched on 1" centers for easy adjustment), one pair back sway braces, 2 pair side sway braces and selected number of shelves with corresponding hardware (nuts and bolts for top and bottom shelf, clips for intermediate shelves). Shelves are engineered for superior strength and are triple bent on all four sides. See shelf chart below for load capacity. Easy and quick assembly. Available in Gray.



20G-75-1836-5

**OPEN SHELVING
UNITS ARE IDEAL
FOR INDUSTRIAL
AND COMMERCIAL
STORAGE AND
ORGANIZATION.**



18G-1236SHELF

IRONMAN

18 & 20 Gauge Steel Shelves

Quantum's IRONMAN 18 & 20 gauge shelves are 1-1/4" perforated with triple bends on all four sides.

SHELF D" x W"	MODEL NO.	LOAD CAPACITY	SHIP WGT	MODEL NO.	LOAD CAPACITY	SHIP WGT
Additional Shelves						
12" x 36"	18G-1236SHELF	800	8 lbs	20G-1236SHELF	450	6 lbs
15" x 36"	18G-1536SHELF	775	10 lbs	20G-1536SHELF	450	7 lbs
18" x 36"	18G-1836SHELF	800	11 lbs	20G-1836SHELF	450	9 lbs
24" x 36"	18G-2436SHELF	750	15 lbs	20G-2436SHELF	450	12 lbs
30" x 36"	18G-3036SHELF	700	18 lbs	20G-3036SHELF	350	14 lbs
12" x 42"	18G-1242SHELF	575	9 lbs	20G-1242SHELF	400	8 lbs
15" x 42"	18G-1542SHELF	575	11 lbs	20G-1542SHELF	400	9 lbs
18" x 42"	18G-1842SHELF	575	13 lbs	20G-1842SHELF	400	10 lbs
24" x 42"	18G-2442SHELF	575	17 lbs	20G-2442SHELF	400	12 lbs
30" x 42"	18G-3042SHELF	500	21 lbs	20G-3042SHELF	300	14 lbs
12" x 48"	18G-1248SHELF	500	11 lbs	20G-1248SHELF	350	9 lbs
15" x 48"	18G-1548SHELF	500	13 lbs	20G-1548SHELF	350	10 lbs
18" x 48"	18G-1848SHELF	500	15 lbs	20G-1848SHELF	350	11 lbs
24" x 48"	18G-2448SHELF	500	19 lbs	20G-2448SHELF	350	14 lbs
30" x 48"	18G-3048SHELF	400	24 lbs	20G-3048SHELF	250	18 lbs

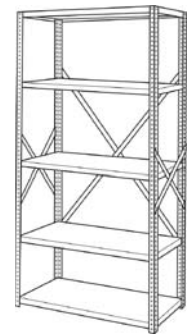

SHELF D" x W"	39"H			
	18 GAUGE		20 GAUGE	
MODEL NO.	SHIP WGT	MODEL NO.	SHIP WGT	
4 Shelf, 39"H Open Shelving Unit				
12" x 36"	18G-39-1236-4	45 lbs	20G-39-1236-4	40 lbs
15" x 36"	18G-39-1536-4	56 lbs	20G-39-1536-4	43 lbs
18" x 36"	18G-39-1836-4	63 lbs	20G-39-1836-4	47 lbs
24" x 36"	18G-39-2436-4	77 lbs	20G-39-2436-4	59 lbs
30" x 36"	18G-39-3036-4	91 lbs	20G-39-3036-4	69 lbs
12" x 42"	18G-39-1242-4	54 lbs	20G-39-1242-4	46 lbs
15" x 42"	18G-39-1542-4	58 lbs	20G-39-1542-4	49 lbs
18" x 42"	18G-39-1842-4	71 lbs	20G-39-1842-4	52 lbs
24" x 42"	18G-39-2442-4	87 lbs	20G-39-2442-4	63 lbs
30" x 42"	18G-39-3042-4	102 lbs	20G-39-3042-4	72 lbs
12" x 48"	18G-39-1248-4	61 lbs	20G-39-1248-4	49 lbs
15" x 48"	18G-39-1548-4	69 lbs	20G-39-1548-4	52 lbs
18" x 48"	18G-39-1848-4	77 lbs	20G-39-1848-4	59 lbs
24" x 48"	18G-39-2448-4	96 lbs	20G-39-2448-4	71 lbs
30" x 48"	18G-39-3048-4	113 lbs	20G-39-3048-4	85 lbs
5 Shelf, 39"H Open Shelving Unit				
12" x 36"	18G-39-1236-5	53 lbs	20G-39-1236-5	47 lbs
15" x 36"	18G-39-1536-5	67 lbs	20G-39-1536-5	50 lbs
18" x 36"	18G-39-1836-5	75 lbs	20G-39-1836-5	55 lbs
24" x 36"	18G-39-2436-5	93 lbs	20G-39-2436-5	70 lbs
30" x 36"	18G-39-3036-5	110 lbs	20G-39-3036-5	83 lbs
12" x 42"	18G-39-1242-5	64 lbs	20G-39-1242-5	54 lbs
15" x 42"	18G-39-1542-5	68 lbs	20G-39-1542-5	57 lbs
18" x 42"	18G-39-1842-5	85 lbs	20G-39-1842-5	62 lbs
24" x 42"	18G-39-2442-5	105 lbs	20G-39-2442-5	74 lbs
30" x 42"	18G-39-3042-5	124 lbs	20G-39-3042-5	86 lbs
12" x 48"	18G-39-1248-5	73 lbs	20G-39-1248-5	58 lbs
15" x 48"	18G-39-1548-5	83 lbs	20G-39-1548-5	62 lbs
18" x 48"	18G-39-1848-5	93 lbs	20G-39-1848-5	70 lbs
24" x 48"	18G-39-2448-5	116 lbs	20G-39-2448-5	85 lbs
30" x 48"	18G-39-3048-5	138 lbs	20G-39-3048-5	103 lbs
6 Shelf, 39"H Open Shelving Unit				
12" x 36"	18G-39-1236-6	61 lbs	20G-39-1236-6	54 lbs
15" x 36"	18G-39-1536-6	78 lbs	20G-39-1536-6	57 lbs
18" x 36"	18G-39-1836-6	87 lbs	20G-39-1836-6	63 lbs
24" x 36"	18G-39-2436-6	109 lbs	20G-39-2436-6	81 lbs
30" x 36"	18G-39-3036-6	129 lbs	20G-39-3036-6	97 lbs
12" x 42"	18G-39-1242-6	74 lbs	20G-39-1242-6	62 lbs
15" x 42"	18G-39-1542-6	78 lbs	20G-39-1542-6	65 lbs
18" x 42"	18G-39-1842-6	99 lbs	20G-39-1842-6	72 lbs
24" x 42"	18G-39-2442-6	123 lbs	20G-39-2442-6	85 lbs
30" x 42"	18G-39-3042-6	146 lbs	20G-39-3042-6	100 lbs
12" x 48"	18G-39-1248-6	85 lbs	20G-39-1248-6	67 lbs
15" x 48"	18G-39-1548-6	97 lbs	20G-39-1548-6	72 lbs
18" x 48"	18G-39-1848-6	109 lbs	20G-39-1848-6	81 lbs
24" x 48"	18G-39-2448-6	136 lbs	20G-39-2448-6	99 lbs
30" x 48"	18G-39-3048-6	163 lbs	20G-39-3048-6	120 lbs

OPEN STEEL SHELVING - STARTER UNITS

- High visibility allows for easy stocking and retrieval
- Intermediate clip shelves make for easy bolt-free assembly and adjustment
- Shelves are adjustable on 1" increments
- Sway braces on side and back provide stability

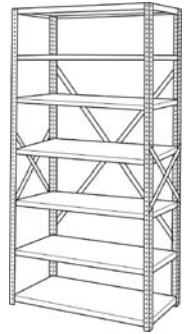
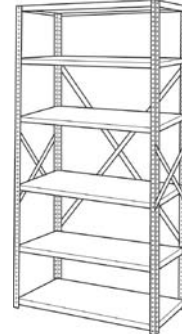
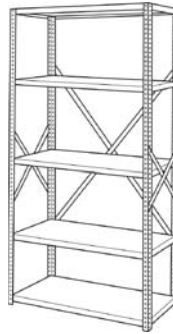

Additional Shelves and Clips available, see pages 78 & 84.
22 Gauge Shelving also available in three different sizes, see page 86.

SHELF D" x W"	75"H				87"H				99"H			
	18 GAUGE		20 GAUGE		18 GAUGE		20 GAUGE		18 GAUGE		20 GAUGE	
MODEL NO.	SHIP WGT	MODEL NO.	SHIP WGT	MODEL NO.	SHIP WGT	MODEL NO.	SHIP WGT	MODEL NO.	SHIP WGT	MODEL NO.	SHIP WGT	
5 Shelf, 75"H Open Shelving Unit				5 Shelf, 87"H Open Shelving Unit				5 Shelf, 99"H Open Shelving Unit				
12" x 36"	18G-75-1236-5	68 lbs	20G-75-1236-5	60 lbs	18G-87-1236-5	71 lbs	20G-87-1236-5	63 lbs	18G-99-1236-5	73 lbs	20G-99-1236-5	65 lbs
15" x 36"	18G-75-1536-5	80 lbs	20G-75-1536-5	63 lbs	18G-87-1536-5	83 lbs	20G-87-1536-5	66 lbs	18G-99-1536-5	85 lbs	20G-99-1536-5	68 lbs
18" x 36"	18G-75-1836-5	88 lbs	20G-75-1836-5	69 lbs	18G-87-1836-5	91 lbs	20G-87-1836-5	72 lbs	18G-99-1836-5	93 lbs	20G-99-1836-5	74 lbs
24" x 36"	18G-75-2436-5	108 lbs	20G-75-2436-5	85 lbs	18G-87-2436-5	111 lbs	20G-87-2436-5	88 lbs	18G-99-2436-5	113 lbs	20G-99-2436-5	90 lbs
30" x 36"	18G-75-3036-5	124 lbs	20G-75-3036-5	97 lbs	18G-87-3036-5	127 lbs	20G-87-3036-5	100 lbs	18G-99-3036-5	129 lbs	20G-99-3036-5	102 lbs
12" x 42"	18G-75-1242-5	80 lbs	20G-75-1242-5	68 lbs	18G-87-1242-5	83 lbs	20G-87-1242-5	72 lbs	18G-99-1242-5	85 lbs	20G-99-1242-5	74 lbs
15" x 42"	18G-75-1542-5	89 lbs	20G-75-1542-5	70 lbs	18G-87-1542-5	92 lbs	20G-87-1542-5	73 lbs	18G-99-1542-5	94 lbs	20G-99-1542-5	75 lbs
18" x 42"	18G-75-1842-5	98 lbs	20G-75-1842-5	77 lbs	18G-87-1842-5	101 lbs	20G-87-1842-5	79 lbs	18G-99-1842-5	103 lbs	20G-99-1842-5	81 lbs
24" x 42"	18G-75-2442-5	121 lbs	20G-75-2442-5	91 lbs	18G-87-2442-5	123 lbs	20G-87-2442-5	93 lbs	18G-99-2442-5	125 lbs	20G-99-2442-5	95 lbs
30" x 42"	18G-75-3042-5	139 lbs	20G-75-3042-5	101 lbs	18G-87-3042-5	142 lbs	20G-87-3042-5	105 lbs	18G-99-3042-5	144 lbs	20G-99-3042-5	106 lbs
12" x 48"	18G-75-1248-5	87 lbs	20G-75-1248-5	74 lbs	18G-87-1248-5	90 lbs	20G-87-1248-5	77 lbs	18G-99-1248-5	92 lbs	20G-99-1248-5	79 lbs
15" x 48"	18G-75-1548-5	97 lbs	20G-75-1548-5	77 lbs	18G-87-1548-5	99 lbs	20G-87-1548-5	78 lbs	18G-99-1548-5	101 lbs	20G-99-1548-5	81 lbs
18" x 48"	18G-75-1848-5	106 lbs	20G-75-1848-5	82 lbs	18G-87-1848-5	109 lbs	20G-87-1848-5	85 lbs	18G-99-1848-5	111 lbs	20G-99-1848-5	87 lbs
24" x 48"	18G-75-2448-5	132 lbs	20G-75-2448-5	101 lbs	18G-87-2448-5	135 lbs	20G-87-2448-5	103 lbs	18G-99-2448-5	137 lbs	20G-99-2448-5	105 lbs
30" x 48"	18G-75-3048-5	153 lbs	20G-75-3048-5	119 lbs	18G-87-3048-5	156 lbs	20G-87-3048-5	121 lbs	18G-99-3048-5	158 lbs	20G-99-3048-5	123 lbs
6 Shelf, 75"H Open Shelving Unit				6 Shelf, 87"H Open Shelving Unit				6 Shelf, 99"H Open Shelving Unit				
12" x 36"	18G-75-1236-6	76 lbs	20G-75-1236-6	67 lbs	18G-87-1236-6	79 lbs	20G-87-1236-6	70 lbs	18G-99-1236-6	81 lbs	20G-99-1236-6	72 lbs
15" x 36"	18G-75-1536-6	91 lbs	20G-75-1536-6	71 lbs	18G-87-1536-6	94 lbs	20G-87-1536-6	74 lbs	18G-99-1536-6	96 lbs	20G-99-1536-6	76 lbs
18" x 36"	18G-75-1836-6	100 lbs	20G-75-1836-6	76 lbs	18G-87-1836-6	104 lbs	20G-87-1836-6	80 lbs	18G-99-1836-6	106 lbs	20G-99-1836-6	82 lbs
24" x 36"	18G-75-2436-6	124 lbs	20G-75-2436-6	96 lbs	18G-87-2436-6	127 lbs	20G-87-2436-6	99 lbs	18G-99-2436-6	129 lbs	20G-99-2436-6	101 lbs
30" x 36"	18G-75-3036-6	143 lbs	20G-75-3036-6	111 lbs	18G-87-3036-6	146 lbs	20G-87-3036-6	114 lbs	18G-99-3036-6	148 lbs	20G-99-3036-6	116 lbs
12" x 42"	18G-75-1242-6	91 lbs	20G-75-1242-6	77 lbs	18G-87-1242-6	94 lbs	20G-87-1242-6	80 lbs	18G-99-1242-6	96 lbs	20G-99-1242-6	82 lbs
15" x 42"	18G-75-1542-6	101 lbs	20G-75-1542-6	79 lbs	18G-87-1542-6	104 lbs	20G-87-1542-6	81 lbs	18G-99-1542-6	106 lbs	20G-99-1542-6	83 lbs
18" x 42"	18G-75-1842-6	111 lbs	20G-75-1842-6	85 lbs	18G-87-1842-6	115 lbs	20G-87-1842-6	89 lbs	18G-99-1842-6	117 lbs	20G-99-1842-6	91 lbs
24" x 42"	18G-75-2442-6	139 lbs	20G-75-2442-6	103 lbs	18G-87-2442-6	142 lbs	20G-87-2442-6	106 lbs	18G-99-2442-6	144 lbs	20G-99-2442-6	108 lbs
30" x 42"	18G-75-3042-6	161 lbs	20G-75-3042-6	115 lbs	18G-87-3042-6	164 lbs	20G-87-3042-6	118 lbs	18G-99-3042-6	166 lbs	20G-99-3042-6	120 lbs
12" x 48"	18G-75-1248-6	99 lbs	20G-75-1248-6	83 lbs	18G-87-1248-6	102 lbs	20G-87-1248-6	86 lbs	18G-99-1248-6	104 lbs	20G-99-1248-6	88 lbs
15" x 48"	18G-75-1548-6	110 lbs	20G-75-1548-6	86 lbs	18G-87-1548-6	113 lbs	20G-87-1548-6	89 lbs	18G-99-1548-6	115 lbs	20G-99-1548-6	91 lbs
18" x 48"	18G-75-1848-6	122 lbs	20G-75-1848-6	94 lbs	18G-87-1848-6	125 lbs	20G-87-1848-6	96 lbs	18G-99-1848-6	127 lbs	20G-99-1848-6	98 lbs
24" x 48"	18G-75-2448-6	153 lbs	20G-75-2448-6	115 lbs	18G-87-2448-6	155 lbs	20G-87-2448-6	118 lbs	18G-99-2448-6	157 lbs	20G-99-2448-6	120 lbs
30" x 48"	18G-75-3048-6	178 lbs	20G-75-3048-6	136 lbs	18G-87-3048-6	181 lbs	20G-87-3048-6	139 lbs	18G-99-3048-6	183 lbs	20G-99-3048-6	141 lbs
7 Shelf, 75"H Open Shelving Unit				7 Shelf, 87"H Open Shelving Unit				7 Shelf, 99"H Open Shelving Unit				
12" x 36"	18G-75-1236-7	85 lbs	20G-75-1236-7	74 lbs	18G-87-1236-7	87 lbs	20G-87-1236-7	77 lbs	18G-99-1236-7	89 lbs	20G-99-1236-7	79 lbs
15" x 36"	18G-75-1536-7	102 lbs	20G-75-1536-7	78 lbs	18G-87-1536-7	105 lbs	20G-87-1536-7	81 lbs	18G-99-1536-7	107 lbs	20G-99-1536-7	83 lbs
18" x 36"	18G-75-1836-7	113 lbs	20G-75-1836-7	86 lbs	18G-87-1836-7	116 lbs	20G-87-1836-7	89 lbs	18G-99-1836-7	118 lbs	20G-99-1836-7	91 lbs
24" x 36"	18G-75-2436-7	140 lbs	20G-75-2436-7	109 lbs	18G-87-2436-7	143 lbs	20G-87-2436-7	110 lbs	18G-99-2436-7	144 lbs	20G-99-2436-7	112 lbs
30" x 36"	18G-75-3036-7	162 lbs	20G-75-3036-7	125 lbs	18G-87-3036-7	165 lbs	20G-87-3036-7	128 lbs	18G-99-3036-7	167 lbs	20G-99-3036-7	130 lbs
12" x 42"	18G-75-1242-7	102 lbs	20G-75-1242-7	86 lbs	18G-87-1242-7	105 lbs	20G-87-1242-7	89 lbs	18G-99-1242-7	107 lbs	20G-99-1242-7	91 lbs
15" x 42"	18G-75-1542-7	114 lbs	20G-75-1542-7	87 lbs	18G-87-1542-7	117 lbs	20G-87-1542-7	90 lbs	18G-99-1542-7	119 lbs	20G-99-1542-7	92 lbs
18" x 42"	18G-75-1842-7	126 lbs	20G-75-1842-7	96 lbs	18G-87-1842-7	129 lbs	20G-87-1842-7	99 lbs	18G-99-1842-7	131 lbs	20G-99-1842-7	101 lbs
24" x 42"	18G-75-2442-7	157 lbs	20G-75-2442-7	115 lbs	18G-87-2442-7	160 lbs	20G-87-2442-7	118 lbs	18G-99-2442-7	162 lbs	20G-99-2442-7	120 lbs
30" x 42"	18G-75-3042-7	183 lbs	20G-75-3042-7	130 lbs	18G-87-3042-7	186 lbs	20G-87-3042-7	133 lbs	18G-99-3042-7	188 lbs	20G-99-3042-7	135 lbs
12" x 48"	18G-75-1248-7	111 lbs	20G-75-1248-7	93 lbs	18G-87-1248-7	114 lbs	20G-87-1248-7	96 lbs	18G-99-1248-7	116 lbs	20G-99-1248-7	98 lbs
15" x 48"	18G-75-1548-7	124 lbs	20G-75-1548-7	96 lbs	18G-87-1548-7	127 lbs	20G-87-1548-7	99 lbs	18G-99-1548-7	129 lbs	20G-99-1548-7	101 lbs
18" x 48"	18G-75-1848-7	138 lbs	20G-75-1848-7	105 lbs	18G-87-1848-7	141 lbs	20G-87-1848-7	108 lbs	18G-99-1848-7	143 lbs	20G-99-1848-7	110 lbs
24" x 48"	18G-75-2448-7	173 lbs	20G-75-2448-7	129 lbs	18G-87-2448-7	176 lbs	20G-87-2448-7	132 lbs	18G-99-2448-7	178 lbs	20G-99-2448-7	134 lbs
30" x 48"	18G-75-3048-7	203 lbs	20G-75-3048-7	154 lbs	18G-87-3048-7	205 lbs	20G-87-3048-7	157 lbs	18G-99-3048-7	207 lbs	20G-99-3048-7	159 lbs

IRONMAN 18 & 20 GAUGE STEEL OPEN SHELVING

IRONMAN 18 & 20 Gauge Steel Open Shelving - Add-On Units

Easy access to product, high visibility and air flow from all sides. Units are available in 18 & 20 gauge, 4 heights and 15 shelf sizes. Each add-on unit includes 2 offset posts (punched on 1" centers for easy adjustment), one beaded post, one pair back sway braces, one pair side sway braces and selected number of shelves with corresponding hardware (nuts and bolts for top and bottom shelves, clips for intermediate shelves). Shelves are engineered for superior strength and are triple bent on all four sides. See shelf chart on page 78 for load capacity. Easy and quick assembly. Available in Gray.

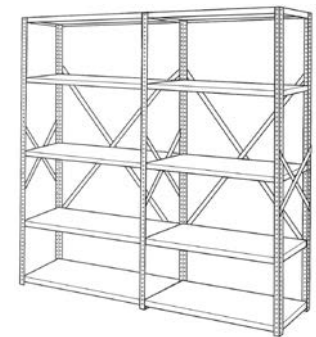

20G-75-1836-5 + AD20G-75-1836-5



**EASY ACCESS TO PRODUCT,
HIGH VISIBILITY AND
AIR FLOW FROM ALL SIDES.**

IRONMAN Steel Posts

Quantum's IRONMAN Offset posts are 14 gauge 1-1/4" x 1-29/32" punched on 1" centers and can be used with shelf clips or nut and bolts. Angle posts are 14 gauge, 1-1/4" x 1-1/4" punched on 1" centers and can be used with nuts and bolts. Beaded posts are 14 gauge, 1-29/32" x 1-29/32" punched on 1" centers and can be used with shelf clips or nut and bolts. Beaded posts are used for continuous runs of shelving.

MODEL NO.	POST HEIGHT	SHIP WGT
Offset Posts		
OP-39	39"	14 lbs
OP-75	75"	22 lbs
OP-87	87"	26 lbs
OP-99	99"	30 lbs
OP-123	123"	38 lbs
OP-147	147"	42 lbs
Angle Posts		
AP-39	39"	14 lbs
AP-75	75"	26 lbs
Beaded Posts		
BP-39	39"	11 lbs
BP-75	75"	17 lbs
BP-87	87"	20 lbs
BP-99	99"	23 lbs
BP-123	123"	29 lbs
BP-147	147"	32 lbs



Angle Post



Beaded Post



Offset Post

SHELF D" x W"	39"H			
	18 GAUGE		20 GAUGE	
MODEL NO.	SHIP WGT	MODEL NO.	SHIP WGT	
4 Shelf, 39"H Open Shelving Unit				
12" x 36"	AD18G-39-1236-4	40 lbs	AD20G-39-1236-4	35 lbs
15" x 36"	AD18G-39-1536-4	51 lbs	AD20G-39-1536-4	38 lbs
18" x 36"	AD18G-39-1836-4	57 lbs	AD20G-39-1836-4	42 lbs
24" x 36"	AD18G-39-2436-4	72 lbs	AD20G-39-2436-4	54 lbs
30" x 36"	AD18G-39-3036-4	86 lbs	AD20G-39-3036-4	64 lbs
12" x 42"	AD18G-39-1242-4	49 lbs	AD20G-39-1242-4	41 lbs
15" x 42"	AD18G-39-1542-4	53 lbs	AD20G-39-1542-4	44 lbs
18" x 42"	AD18G-39-1842-4	66 lbs	AD20G-39-1842-4	47 lbs
24" x 42"	AD18G-39-2442-4	82 lbs	AD20G-39-2442-4	58 lbs
30" x 42"	AD18G-39-3042-4	97 lbs	AD20G-39-3042-4	67 lbs
12" x 48"	AD18G-39-1248-4	56 lbs	AD20G-39-1248-4	44 lbs
15" x 48"	AD18G-39-1548-4	64 lbs	AD20G-39-1548-4	47 lbs
18" x 48"	AD18G-39-1848-4	72 lbs	AD20G-39-1848-4	54 lbs
24" x 48"	AD18G-39-2448-4	91 lbs	AD20G-39-2448-4	66 lbs
30" x 48"	AD18G-39-3048-4	108 lbs	AD20G-39-3048-4	80 lbs
5 Shelf, 39"H Open Shelving Unit				
12" x 36"	AD18G-39-1236-5	48 lbs	AD20G-39-1236-5	42 lbs
15" x 36"	AD18G-39-1536-5	62 lbs	AD20G-39-1536-5	45 lbs
18" x 36"	AD18G-39-1836-5	70 lbs	AD20G-39-1836-5	50 lbs
24" x 36"	AD18G-39-2436-5	88 lbs	AD20G-39-2436-5	65 lbs
30" x 36"	AD18G-39-3036-5	105 lbs	AD20G-39-3036-5	78 lbs
12" x 42"	AD18G-39-1242-5	59 lbs	AD20G-39-1242-5	49 lbs
15" x 42"	AD18G-39-1542-5	63 lbs	AD20G-39-1542-5	52 lbs
18" x 42"	AD18G-39-1842-5	80 lbs	AD20G-39-1842-5	57 lbs
24" x 42"	AD18G-39-2442-5	100 lbs	AD20G-39-2442-5	69 lbs
30" x 42"	AD18G-39-3042-5	119 lbs	AD20G-39-3042-5	81 lbs
12" x 48"	AD18G-39-1248-5	68 lbs	AD20G-39-1248-5	53 lbs
15" x 48"	AD18G-39-1548-5	78 lbs	AD20G-39-1548-5	57 lbs
18" x 48"	AD18G-39-1848-5	88 lbs	AD20G-39-1848-5	65 lbs
24" x 48"	AD18G-39-2448-5	111 lbs	AD20G-39-2448-5	80 lbs
30" x 48"	AD18G-39-3048-5	133 lbs	AD20G-39-3048-5	98 lbs
6 Shelf, 39"H Open Shelving Unit				
12" x 36"	AD18G-39-1236-6	56 lbs	AD20G-39-1236-6	49 lbs
15" x 36"	AD18G-39-1536-6	73 lbs	AD20G-39-1536-6	52 lbs
18" x 36"	AD18G-39-1836-6	82 lbs	AD20G-39-1836-6	58 lbs
24" x 36"	AD18G-39-2436-6	104 lbs	AD20G-39-2436-6	76 lbs
30" x 36"	AD18G-39-3036-6	124 lbs	AD20G-39-3036-6	92 lbs
12" x 42"	AD18G-39-1242-6	69 lbs	AD20G-39-1242-6	57 lbs
15" x 42"	AD18G-39-1542-6	73 lbs	AD20G-39-1542-6	60 lbs
18" x 42"	AD18G-39-1842-6	94 lbs	AD20G-39-1842-6	57 lbs
24" x 42"	AD18G-39-2442-6	118 lbs	AD20G-39-2442-6	80 lbs
30" x 42"	AD18G-39-3042-6	141 lbs	AD20G-39-3042-6	95 lbs
12" x 48"	AD18G-39-1248-6	80 lbs	AD20G-39-1248-6	62 lbs
15" x 48"	AD18G-39-1548-6	92 lbs	AD20G-39-1548-6	57 lbs
18" x 48"	AD18G-39-1848-6	104 lbs	AD20G-39-1848-6	76 lbs
24" x 48"	AD18G-39-2448-6	131 lbs	AD20G-39-2448-6	94 lbs
30" x 48"	AD18G-39-3048-6	158 lbs	AD20G-39-3048-6	115 lbs

OPEN STEEL SHELVING - ADD-ON UNITS

- High visibility allows for easy stocking and retrieval
- Intermediate clip shelves make for easy bolt-free assembly and adjustment
- Shelves are adjustable on 1" increments
- Sway braces on side and back provide stability



Additional Shelves and Clips available, see components pages 78 & 84.
22 Gauge Shelving also available in three different sizes, see page 86.

SHELF D" x W"	75"H				87"H				99"H			
	18 GAUGE		20 GAUGE		18 GAUGE		20 GAUGE		18 GAUGE		20 GAUGE	
	MODEL NO.	SHIP WGT	MODEL NO.	SHIP WGT	MODEL NO.	SHIP WGT	MODEL NO.	SHIP WGT	MODEL NO.	SHIP WGT	MODEL NO.	SHIP WGT
5 Shelf, 75"H Open Shelving Unit				5 Shelf, 87"H Open Shelving Unit				5 Shelf, 99"H Open Shelving Unit				
12" x 36"	AD18G-75-1236-5	61 lbs	AD20G-75-1236-5	53 lbs	AD18G-87-1236-5	63 lbs	AD20G-87-1236-5	55 lbs	AD18G-99-1236-5	64 lbs	AD20G-99-1236-5	56 lbs
15" x 36"	AD18G-75-1536-5	73 lbs	AD20G-75-1536-5	56 lbs	AD18G-87-1536-5	75 lbs	AD20G-87-1536-5	58 lbs	AD18G-99-1536-5	76 lbs	AD20G-99-1536-5	59 lbs
18" x 36"	AD18G-75-1836-5	81 lbs	AD20G-75-1836-5	62 lbs	AD18G-87-1836-5	83 lbs	AD20G-87-1836-5	64 lbs	AD18G-99-1836-5	84 lbs	AD20G-99-1836-5	65 lbs
24" x 36"	AD18G-75-2436-5	101 lbs	AD20G-75-2436-5	78 lbs	AD18G-87-2436-5	103 lbs	AD20G-87-2436-5	80 lbs	AD18G-99-2436-5	104 lbs	AD20G-99-2436-5	81 lbs
30" x 36"	AD18G-75-3036-5	117 lbs	AD20G-75-3036-5	90 lbs	AD18G-87-3036-5	119 lbs	AD20G-87-3036-5	92 lbs	AD18G-99-3036-5	120 lbs	AD20G-99-3036-5	93 lbs
12" x 42"	AD18G-75-1242-5	73 lbs	AD20G-75-1242-5	61 lbs	AD18G-87-1242-5	75 lbs	AD20G-87-1242-5	64 lbs	AD18G-99-1242-5	76 lbs	AD20G-99-1242-5	65 lbs
15" x 42"	AD18G-75-1542-5	82 lbs	AD20G-75-1542-5	63 lbs	AD18G-87-1542-5	84 lbs	AD20G-87-1542-5	65 lbs	AD18G-99-1542-5	85 lbs	AD20G-99-1542-5	66 lbs
18" x 42"	AD18G-75-1842-5	91 lbs	AD20G-75-1842-5	70 lbs	AD18G-87-1842-5	93 lbs	AD20G-87-1842-5	71 lbs	AD18G-99-1842-5	94 lbs	AD20G-99-1842-5	72 lbs
24" x 42"	AD18G-75-2442-5	114 lbs	AD20G-75-2442-5	84 lbs	AD18G-87-2442-5	115 lbs	AD20G-87-2442-5	85 lbs	AD18G-99-2442-5	116 lbs	AD20G-99-2442-5	86 lbs
30" x 42"	AD18G-75-3042-5	132 lbs	AD20G-75-3042-5	94 lbs	AD18G-87-3042-5	134 lbs	AD20G-87-3042-5	97 lbs	AD18G-99-3042-5	135 lbs	AD20G-99-3042-5	97 lbs
12" x 48"	AD18G-75-1248-5	80 lbs	AD20G-75-1248-5	67 lbs	AD18G-87-1248-5	82 lbs	AD20G-87-1248-5	69 lbs	AD18G-99-1248-5	83 lbs	AD20G-99-1248-5	70 lbs
15" x 48"	AD18G-75-1548-5	90 lbs	AD20G-75-1548-5	70 lbs	AD18G-87-1548-5	91 lbs	AD20G-87-1548-5	70 lbs	AD18G-99-1548-5	92 lbs	AD20G-99-1548-5	72 lbs
18" x 48"	AD18G-75-1848-5	99 lbs	AD20G-75-1848-5	75 lbs	AD18G-87-1848-5	101 lbs	AD20G-87-1848-5	77 lbs	AD18G-99-1848-5	102 lbs	AD20G-99-1848-5	78 lbs
24" x 48"	AD18G-75-2448-5	125 lbs	AD20G-75-2448-5	94 lbs	AD18G-87-2448-5	127 lbs	AD20G-87-2448-5	95 lbs	AD18G-99-2448-5	128 lbs	AD20G-99-2448-5	96 lbs
30" x 48"	AD18G-75-3048-5	146 lbs	AD20G-75-3048-5	112 lbs	AD18G-87-3048-5	148 lbs	AD20G-87-3048-5	113 lbs	AD18G-99-3048-5	149 lbs	AD20G-99-3048-5	114 lbs
6 Shelf, 75"H Open Shelving Unit				6 Shelf, 87"H Open Shelving Unit				6 Shelf, 99"H Open Shelving Unit				
12" x 36"	AD18G-75-1236-6	69 lbs	AD20G-75-1236-6	60 lbs	AD18G-87-1236-6	71 lbs	AD20G-87-1236-6	62 lbs	AD18G-99-1236-6	72 lbs	AD20G-99-1236-6	63 lbs
15" x 36"	AD18G-75-1536-6	84 lbs	AD20G-75-1536-6	64 lbs	AD18G-87-1536-6	86 lbs	AD20G-87-1536-6	66 lbs	AD18G-99-1536-6	87 lbs	AD20G-99-1536-6	67 lbs
18" x 36"	AD18G-75-1836-6	93 lbs	AD20G-75-1836-6	69 lbs	AD18G-87-1836-6	96 lbs	AD20G-87-1836-6	72 lbs	AD18G-99-1836-6	97 lbs	AD20G-99-1836-6	73 lbs
24" x 36"	AD18G-75-2436-6	117 lbs	AD20G-75-2436-6	89 lbs	AD18G-87-2436-6	119 lbs	AD20G-87-2436-6	91 lbs	AD18G-99-2436-6	120 lbs	AD20G-99-2436-6	92 lbs
30" x 36"	AD18G-75-3036-6	136 lbs	AD20G-75-3036-6	104 lbs	AD18G-87-3036-6	138 lbs	AD20G-87-3036-6	106 lbs	AD18G-99-3036-6	139 lbs	AD20G-99-3036-6	107 lbs
12" x 42"	AD18G-75-1242-6	84 lbs	AD20G-75-1242-6	70 lbs	AD18G-87-1242-6	86 lbs	AD20G-87-1242-6	72 lbs	AD18G-99-1242-6	87 lbs	AD20G-99-1242-6	73 lbs
15" x 42"	AD18G-75-1542-6	94 lbs	AD20G-75-1542-6	72 lbs	AD18G-87-1542-6	96 lbs	AD20G-87-1542-6	73 lbs	AD18G-99-1542-6	97 lbs	AD20G-99-1542-6	74 lbs
18" x 42"	AD18G-75-1842-6	104 lbs	AD20G-75-1842-6	78 lbs	AD18G-87-1842-6	107 lbs	AD20G-87-1842-6	81 lbs	AD18G-99-1842-6	108 lbs	AD20G-99-1842-6	82 lbs
24" x 42"	AD18G-75-2442-6	132 lbs	AD20G-75-2442-6	96 lbs	AD18G-87-2442-6	134 lbs	AD20G-87-2442-6	98 lbs	AD18G-99-2442-6	135 lbs	AD20G-99-2442-6	99 lbs
30" x 42"	AD18G-75-3042-6	154 lbs	AD20G-75-3042-6	108 lbs	AD18G-87-3042-6	156 lbs	AD20G-87-3042-6	110 lbs	AD18G-99-3042-6	157 lbs	AD20G-99-3042-6	111 lbs
12" x 48"	AD18G-75-1248-6	92 lbs	AD20G-75-1248-6	76 lbs	AD18G-87-1248-6	94 lbs	AD20G-87-1248-6	78 lbs	AD18G-99-1248-6	95 lbs	AD20G-99-1248-6	79 lbs
15" x 48"	AD18G-75-1548-6	103 lbs	AD20G-75-1548-6	79 lbs	AD18G-87-1548-6	105 lbs	AD20G-87-1548-6	81 lbs	AD18G-99-1548-6	106 lbs	AD20G-99-1548-6	82 lbs
18" x 48"	AD18G-75-1848-6	115 lbs	AD20G-75-1848-6	87 lbs	AD18G-87-1848-6	117 lbs	AD20G-87-1848-6	88 lbs	AD18G-99-1848-6	118 lbs	AD20G-99-1848-6	89 lbs
24" x 48"	AD18G-75-2448-6	146 lbs	AD20G-75-2448-6	108 lbs	AD18G-87-2448-6	147 lbs	AD20G-87-2448-6	110 lbs	AD18G-99-2448-6	148 lbs	AD20G-99-2448-6	111 lbs
30" x 48"	AD18G-75-3048-6	171 lbs	AD20G-75-3048-6	129 lbs	AD18G-87-3048-6	173 lbs	AD20G-87-3048-6	131 lbs	AD18G-99-3048-6	174 lbs	AD20G-99-3048-6	132 lbs
7 Shelf, 75"H Open Shelving Unit				7 Shelf, 87"H Open Shelving Unit				7 Shelf, 99"H Open Shelving Unit				
12" x 36"	AD18G-75-1236-7	78 lbs	AD20G-75-1236-7	67 lbs	AD18G-87-1236-7	79 lbs	AD20G-87-1236-7	69 lbs	AD18G-99-1236-7	80 lbs	AD20G-99-1236-7	70 lbs
15" x 36"	AD18G-75-1536-7	95 lbs	AD20G-75-1536-7	71 lbs	AD18G-87-1536-7	97 lbs	AD20G-87-1536-7	73 lbs	AD18G-99-1536-7	98 lbs	AD20G-99-1536-7	74 lbs
18" x 36"	AD18G-75-1836-7	106 lbs	AD20G-75-1836-7	79 lbs	AD18G-87-1836-7	108 lbs	AD20G-87-1836-7	81 lbs	AD18G-99-1836-7	109 lbs	AD20G-99-1836-7	82 lbs
24" x 36"	AD18G-75-2436-7	133 lbs	AD20G-75-2436-7	102 lbs	AD18G-87-2436-7	135 lbs	AD20G-87-2436-7	102 lbs	AD18G-99-2436-7	135 lbs	AD20G-99-2436-7	103 lbs
30" x 36"	AD18G-75-3036-7	155 lbs	AD20G-75-3036-7	118 lbs	AD18G-87-3036-7	157 lbs	AD20G-87-3036-7	120 lbs	AD18G-99-3036-7	158 lbs	AD20G-99-3036-7	121 lbs
12" x 42"	AD18G-75-1242-7	95 lbs	AD20G-75-1242-7	79 lbs	AD18G-87-1242-7	97 lbs	AD20G-87-1242-7	81 lbs	AD18G-99-1242-7	98 lbs	AD20G-99-1242-7	82 lbs
15" x 42"	AD18G-75-1542-7	107 lbs	AD20G-75-1542-7	80 lbs	AD18G-87-1542-7	109 lbs	AD20G-87-1542-7	82 lbs	AD18G-99-1542-7	110 lbs	AD20G-99-1542-7	83 lbs
18" x 42"	AD18G-75-1842-7	119 lbs	AD20G-75-1842-7	89 lbs	AD18G-87-1842-7	121 lbs	AD20G-87-1842-7	91 lbs	AD18G-99-1842-7	122 lbs	AD20G-99-1842-7	92 lbs
24" x 42"	AD18G-75-2442-7	150 lbs	AD20G-75-2442-7	108 lbs	AD18G-87-2442-7	152 lbs	AD20G-87-2442-7	110 lbs	AD18G-99-2442-7	153 lbs	AD20G-99-2442-7	111 lbs
30" x 42"	AD18G-75-3042-7	176 lbs	AD20G-75-3042-7	123 lbs	AD18G-87-3042-7	178 lbs	AD20G-87-3042-7	125 lbs	AD18G-99-3042-7	179 lbs	AD20G-99-3042-7	126 lbs
12" x 48"	AD18G-75-1248-7	104 lbs	AD20G-75-1248-7	86 lbs	AD18G-87-1248-7	106 lbs	AD20G-87-1248-7	88 lbs	AD18G-99-1248-7	107 lbs	AD20G-99-1248-7	89 lbs
15" x 48"	AD18G-75-1548-7	117 lbs	AD20G-75-1548-7	89 lbs	AD18G-87-1548-7	119 lbs	AD20G-87-1548-7	91 lbs	AD18G-99-1548-7	120 lbs	AD20G-99-1548-7	92 lbs
18" x 48"	AD18G-75-1848-7	126 lbs	AD20G-75-1848-7	98 lbs	AD18G-87-1848-7	133 lbs	AD20G-87-1848-7	100 lbs	AD18G-99-1848-7	134 lbs	AD20G-99-1848-7	101 lbs
24" x 48"	AD18G-75-2448-7	166 lbs	AD20G-75-2448-7	122 lbs	AD18G-87-2448-7	168 lbs	AD20G-87-2448-7	124 lbs	AD18G-99-2448-7	169 lbs	AD20G-99-2448-7	125 lbs
30" x 48"	AD18G-75-3048-7	196 lbs	AD20G-75-3048-7	147 lbs	AD18G-87-3048-7	197 lbs	AD20G-87-3048-7	149 lbs	AD18G-99-3048-7	198 lbs	AD20G-99-3048-7	150 lbs

IRONMAN 18 & 20 GAUGE CLOSED STEEL SHELVING

IRONMAN

18 & 20 Gauge Steel Closed Clip Shelving - Starter Units

Quantum's IRONMAN Closed Shelving Units are ideal for industrial and commercial storage and organization. Closed shelving provides extra protection from dirt & dust, creates separation between areas and prevents product from falling off sides or back of unit. Units are available in 18 & 20 gauge, 4 heights and 15 shelf sizes. Each starter unit includes 4 offset posts (**punched on 1" centers for easy adjustment**), one back panel, 2 side panels and selected number of shelves with corresponding hardware (**nuts and bolts for top and bottom shelves, clips for intermediate shelves**). See shelf chart on **page 78** for load weight capacity. Easy and quick assembly. Available in Gray.

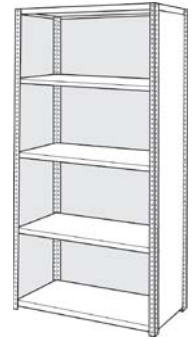

**EXTRA PROTECTION FROM
DIRT & DUST, PREVENTS
PRODUCT FROM FALLING OFF
SIDES OR BACK OF UNIT.**



IRONMAN

Back and Side Panels

Offset back and side panels to be used with offset posts. Back and side panels are designed for extra protection against dirt & dust, creates separation between areas and provides a more orderly appearance. Back and side panels replace back and side sway braces. Order two side panels and one back panel per unit.



CL20G-75-1836-5

MODEL NO.	SHIP WGT
Side Panels	
SP-1239	4 lbs
SP-1539	5 lbs
SP-1839	6 lbs
SP-2439	9 lbs
SP-3039	10 lbs
SP-1275	8 lbs
SP-1575	10 lbs
SP-1875	12 lbs
SP-2475	18 lbs
SP-3075	20 lbs
SP-1287	12 lbs
SP-1587	15 lbs
SP-1887	18 lbs
SP-2487	27 lbs
SP-3087	30 lbs
SP-1299	12 lbs
SP-1599	15 lbs
SP-1899	18 lbs
SP-2499	27 lbs
SP-3099	30 lbs
Back Panels	
BP-3639	13 lbs
BP-4239	15 lbs
BP-4839	17 lbs
BP-3675	26 lbs
BP-4275	30 lbs
BP-4875	34 lbs
BP-3687	39 lbs
BP-4287	45 lbs
BP-4887	51 lbs
BP-3699	39 lbs
BP-4299	45 lbs
BP-4899	51 lbs

SHELF D" x W"	39"H			
	18 GAUGE		20 GAUGE	
MODEL NO.	SHIP WGT	MODEL NO.	SHIP WGT	
4 Shelf, 39"H Closed Shelving Unit				
12" x 36"	CL18G-39-1236-4	60 lbs	CL20G-39-1236-4	55 lbs
15" x 36"	CL18G-39-1536-4	72 lbs	CL20G-39-1536-4	59 lbs
18" x 36"	CL18G-39-1836-4	82 lbs	CL20G-39-1836-4	66 lbs
24" x 36"	CL18G-39-2436-4	98 lbs	CL20G-39-2436-4	80 lbs
30" x 36"	CL18G-39-3036-4	114 lbs	CL20G-39-3036-4	92 lbs
12" x 42"	CL18G-39-1242-4	71 lbs	CL20G-39-1242-4	63 lbs
15" x 42"	CL18G-39-1542-4	76 lbs	CL20G-39-1542-4	67 lbs
18" x 42"	CL18G-39-1842-4	91 lbs	CL20G-39-1842-4	72 lbs
24" x 42"	CL18G-39-2442-4	110 lbs	CL20G-39-2442-4	86 lbs
30" x 42"	CL18G-39-3042-4	128 lbs	CL20G-39-3042-4	98 lbs
12" x 48"	CL18G-39-1248-4	82 lbs	CL20G-39-1248-4	70 lbs
15" x 48"	CL18G-39-1548-4	91 lbs	CL20G-39-1548-4	74 lbs
18" x 48"	CL18G-39-1848-4	100 lbs	CL20G-39-1848-4	82 lbs
24" x 48"	CL18G-39-2448-4	122 lbs	CL20G-39-2448-4	97 lbs
30" x 48"	CL18G-39-3048-4	141 lbs	CL20G-39-3048-4	113 lbs
5 Shelf, 39"H Closed Shelving Unit				
12" x 36"	CL18G-39-1236-5	68 lbs	CL20G-39-1236-5	62 lbs
15" x 36"	CL18G-39-1536-5	83 lbs	CL20G-39-1536-5	66 lbs
18" x 36"	CL18G-39-1836-5	94 lbs	CL20G-39-1836-5	74 lbs
24" x 36"	CL18G-39-2436-5	114 lbs	CL20G-39-2436-5	91 lbs
30" x 36"	CL18G-39-3036-5	133 lbs	CL20G-39-3036-5	106 lbs
12" x 42"	CL18G-39-1242-5	81 lbs	CL20G-39-1242-5	71 lbs
15" x 42"	CL18G-39-1542-5	86 lbs	CL20G-39-1542-5	75 lbs
18" x 42"	CL18G-39-1842-5	105 lbs	CL20G-39-1842-5	82 lbs
24" x 42"	CL18G-39-2442-5	128 lbs	CL20G-39-2442-5	97 lbs
30" x 42"	CL18G-39-3042-5	150 lbs	CL20G-39-3042-5	112 lbs
12" x 48"	CL18G-39-1248-5	94 lbs	CL20G-39-1248-5	79 lbs
15" x 48"	CL18G-39-1548-5	105 lbs	CL20G-39-1548-5	84 lbs
18" x 48"	CL18G-39-1848-5	116 lbs	CL20G-39-1848-5	93 lbs
24" x 48"	CL18G-39-2448-5	147 lbs	CL20G-39-2448-5	111 lbs
30" x 48"	CL18G-39-3048-5	166 lbs	CL20G-39-3048-5	131 lbs
6 Shelf, 39"H Closed Shelving Unit				
12" x 36"	CL18G-39-1236-6	76 lbs	CL20G-39-1236-6	69 lbs
15" x 36"	CL18G-39-1536-6	94 lbs	CL20G-39-1536-6	73 lbs
18" x 36"	CL18G-39-1836-6	106 lbs	CL20G-39-1836-6	82 lbs
24" x 36"	CL18G-39-2436-6	130 lbs	CL20G-39-2436-6	102 lbs
30" x 36"	CL18G-39-3036-6	152 lbs	CL20G-39-3036-6	120 lbs
12" x 42"	CL18G-39-1242-6	91 lbs	CL20G-39-1242-6	79 lbs
15" x 42"	CL18G-39-1542-6	96 lbs	CL20G-39-1542-6	83 lbs
18" x 42"	CL18G-39-1842-6	119 lbs	CL20G-39-1842-6	92 lbs
24" x 42"	CL18G-39-2442-6	146 lbs	CL20G-39-2442-6	108 lbs
30" x 42"	CL18G-39-3042-6	172 lbs	CL20G-39-3042-6	126 lbs
12" x 48"	CL18G-39-1248-6	106 lbs	CL20G-39-1248-6	88 lbs
15" x 48"	CL18G-39-1548-6	119 lbs	CL20G-39-1548-6	94 lbs
18" x 48"	CL18G-39-1848-6	132 lbs	CL20G-39-1848-6	104 lbs
24" x 48"	CL18G-39-2448-6	162 lbs	CL20G-39-2448-6	125 lbs
30" x 48"	CL18G-39-3048-6	191 lbs	CL20G-39-3048-6	148 lbs

CLOSED STEEL SHELVING - STARTER UNITS

- Provides extra protection against dirt and dust
- Creates separation between areas
- Clip shelves make for easy bolt-free assembly and adjustment
- Shelves are adjustable on 1" increments
- Panels on side and back provide stability



Additional Shelves and Clips available, see components pages 78 & 84.
22 Gauge Shelving also available in three different sizes, see page 86.

SHELF D" x W"	75"H				87"H				99"H			
	18 GAUGE		20 GAUGE		18 GAUGE		20 GAUGE		18 GAUGE		20 GAUGE	
MODEL NO.	SHIP WGT	MODEL NO.	SHIP WGT	MODEL NO.	SHIP WGT	MODEL NO.	SHIP WGT	MODEL NO.	SHIP WGT	MODEL NO.	SHIP WGT	
5 Shelf, 75"H Closed Shelving Unit				5 Shelf, 87"H Closed Shelving Unit				5 Shelf, 99"H Closed Shelving Unit				
12" x 36"	CL18G-75-1236-5	98 lbs	CL20G-75-1236-5	90 lbs	CL18G-87-1236-5	116 lbs	CL20G-87-1236-5	108 lbs	CL18G-99-1236-5	118 lbs	CL20G-99-1236-5	110 lbs
15" x 36"	CL18G-75-1536-5	112 lbs	CL20G-75-1536-5	95 lbs	CL18G-87-1536-5	131 lbs	CL20G-87-1536-5	114 lbs	CL18G-99-1536-5	133 lbs	CL20G-99-1536-5	116 lbs
18" x 36"	CL18G-75-1836-5	126 lbs	CL20G-75-1836-5	107 lbs	CL18G-87-1836-5	148 lbs	CL20G-87-1836-5	129 lbs	CL18G-99-1836-5	150 lbs	CL20G-99-1836-5	131 lbs
24" x 36"	CL18G-75-2436-5	150 lbs	CL20G-75-2436-5	127 lbs	CL18G-87-2436-5	174 lbs	CL20G-87-2436-5	151 lbs	CL18G-99-2436-5	176 lbs	CL20G-99-2436-5	153 lbs
30" x 36"	CL18G-75-3036-5	170 lbs	CL20G-75-3036-5	143 lbs	CL18G-87-3036-5	196 lbs	CL20G-87-3036-5	169 lbs	CL18G-99-3036-5	198 lbs	CL20G-99-3036-5	171 lbs
12" x 42"	CL18G-75-1242-5	114 lbs	CL20G-75-1242-5	102 lbs	CL18G-87-1242-5	134 lbs	CL20G-87-1242-5	123 lbs	CL18G-99-1242-5	136 lbs	CL20G-99-1242-5	125 lbs
15" x 42"	CL18G-75-1542-5	125 lbs	CL20G-75-1542-5	106 lbs	CL18G-87-1542-5	146 lbs	CL20G-87-1542-5	127 lbs	CL18G-99-1542-5	148 lbs	CL20G-99-1542-5	129 lbs
18" x 42"	CL18G-75-1842-5	138 lbs	CL20G-75-1842-5	117 lbs	CL18G-87-1842-5	161 lbs	CL20G-87-1842-5	139 lbs	CL18G-99-1842-5	163 lbs	CL20G-99-1842-5	141 lbs
24" x 42"	CL18G-75-2442-5	167 lbs	CL20G-75-2442-5	137 lbs	CL18G-87-2442-5	192 lbs	CL20G-87-2442-5	162 lbs	CL18G-99-2442-5	194 lbs	CL20G-99-2442-5	164 lbs
30" x 42"	CL18G-75-3042-5	191 lbs	CL20G-75-3042-5	153 lbs	CL18G-87-3042-5	220 lbs	CL20G-87-3042-5	183 lbs	CL18G-99-3042-5	222 lbs	CL20G-99-3042-5	184 lbs
12" x 48"	CL18G-75-1248-5	129 lbs	CL20G-75-1248-5	116 lbs	CL18G-87-1248-5	153 lbs	CL20G-87-1248-5	140 lbs	CL18G-99-1248-5	155 lbs	CL20G-99-1248-5	142 lbs
15" x 48"	CL18G-75-1548-5	141 lbs	CL20G-75-1548-5	121 lbs	CL18G-87-1548-5	165 lbs	CL20G-87-1548-5	144 lbs	CL18G-99-1548-5	167 lbs	CL20G-99-1548-5	147 lbs
18" x 48"	CL18G-75-1848-5	152 lbs	CL20G-75-1848-5	128 lbs	CL18G-87-1848-5	178 lbs	CL20G-87-1848-5	154 lbs	CL18G-99-1848-5	180 lbs	CL20G-99-1848-5	156 lbs
24" x 48"	CL18G-75-2448-5	184 lbs	CL20G-75-2448-5	153 lbs	CL18G-87-2448-5	213 lbs	CL20G-87-2448-5	181 lbs	CL18G-99-2448-5	215 lbs	CL20G-99-2448-5	183 lbs
30" x 48"	CL18G-75-3048-5	209 lbs	CL20G-75-3048-5	175 lbs	CL18G-87-3048-5	240 lbs	CL20G-87-3048-5	205 lbs	CL18G-99-3048-5	242 lbs	CL20G-99-3048-5	207 lbs
6 Shelf, 75"H Closed Shelving Unit				6 Shelf, 87"H Closed Shelving Unit				6 Shelf, 99"H Closed Shelving Unit				
12" x 36"	CL18G-75-1236-6	106 lbs	CL20G-75-1236-6	97 lbs	CL18G-87-1236-6	124 lbs	CL20G-87-1236-6	115 lbs	CL18G-99-1236-6	126 lbs	CL20G-99-1236-6	117 lbs
15" x 36"	CL18G-75-1536-6	123 lbs	CL20G-75-1536-6	103 lbs	CL18G-87-1536-6	142 lbs	CL20G-87-1536-6	122 lbs	CL18G-99-1536-6	144 lbs	CL20G-99-1536-6	124 lbs
18" x 36"	CL18G-75-1836-6	138 lbs	CL20G-75-1836-6	114 lbs	CL18G-87-1836-6	161 lbs	CL20G-87-1836-6	137 lbs	CL18G-99-1836-6	163 lbs	CL20G-99-1836-6	139 lbs
24" x 36"	CL18G-75-2436-6	166 lbs	CL20G-75-2436-6	138 lbs	CL18G-87-2436-6	190 lbs	CL20G-87-2436-6	162 lbs	CL18G-99-2436-6	192 lbs	CL20G-99-2436-6	164 lbs
30" x 36"	CL18G-75-3036-6	189 lbs	CL20G-75-3036-6	157 lbs	CL18G-87-3036-6	215 lbs	CL20G-87-3036-6	183 lbs	CL18G-99-3036-6	217 lbs	CL20G-99-3036-6	185 lbs
12" x 42"	CL18G-75-1242-6	125 lbs	CL20G-75-1242-6	111 lbs	CL18G-87-1242-6	145 lbs	CL20G-87-1242-6	131 lbs	CL18G-99-1242-6	147 lbs	CL20G-99-1242-6	133 lbs
15" x 42"	CL18G-75-1542-6	137 lbs	CL20G-75-1542-6	115 lbs	CL18G-87-1542-6	158 lbs	CL20G-87-1542-6	135 lbs	CL18G-99-1542-6	160 lbs	CL20G-99-1542-6	137 lbs
18" x 42"	CL18G-75-1842-6	151 lbs	CL20G-75-1842-6	125 lbs	CL18G-87-1842-6	175 lbs	CL20G-87-1842-6	149 lbs	CL18G-99-1842-6	177 lbs	CL20G-99-1842-6	151 lbs
24" x 42"	CL18G-75-2442-6	185 lbs	CL20G-75-2442-6	149 lbs	CL18G-87-2442-6	211 lbs	CL20G-87-2442-6	175 lbs	CL18G-99-2442-6	213 lbs	CL20G-99-2442-6	177 lbs
30" x 42"	CL18G-75-3042-6	213 lbs	CL20G-75-3042-6	167 lbs	CL18G-87-3042-6	242 lbs	CL20G-87-3042-6	196 lbs	CL18G-99-3042-6	244 lbs	CL20G-99-3042-6	198 lbs
12" x 48"	CL18G-75-1248-6	141 lbs	CL20G-75-1248-6	125 lbs	CL18G-87-1248-6	165 lbs	CL20G-87-1248-6	149 lbs	CL18G-99-1248-6	167 lbs	CL20G-99-1248-6	151 lbs
15" x 48"	CL18G-75-1548-6	154 lbs	CL20G-75-1548-6	130 lbs	CL18G-87-1548-6	179 lbs	CL20G-87-1548-6	155 lbs	CL18G-99-1548-6	181 lbs	CL20G-99-1548-6	157 lbs
18" x 48"	CL18G-75-1848-6	168 lbs	CL20G-75-1848-6	140 lbs	CL18G-87-1848-6	194 lbs	CL20G-87-1848-6	165 lbs	CL18G-99-1848-6	196 lbs	CL20G-99-1848-6	167 lbs
24" x 48"	CL18G-75-2448-6	205 lbs	CL20G-75-2448-6	167 lbs	CL18G-87-2448-6	233 lbs	CL20G-87-2448-6	196 lbs	CL18G-99-2448-6	235 lbs	CL20G-99-2448-6	198 lbs
30" x 48"	CL18G-75-3048-6	234 lbs	CL20G-75-3048-6	192 lbs	CL18G-87-3048-6	265 lbs	CL20G-87-3048-6	223 lbs	CL18G-99-3048-6	267 lbs	CL20G-99-3048-6	225 lbs
7 Shelf, 75"H Closed Shelving Unit				7 Shelf, 87"H Closed Shelving Unit				7 Shelf, 99"H Closed Shelving Unit				
12" x 36"	CL18G-75-1236-7	115 lbs	CL20G-75-1236-7	104 lbs	CL18G-87-1236-7	132 lbs	CL20G-87-1236-7	122 lbs	CL18G-99-1236-7	134 lbs	CL20G-99-1236-7	124 lbs
15" x 36"	CL18G-75-1536-7	134 lbs	CL20G-75-1536-7	110 lbs	CL18G-87-1536-7	153 lbs	CL20G-87-1536-7	129 lbs	CL18G-99-1536-7	155 lbs	CL20G-99-1536-7	131 lbs
18" x 36"	CL18G-75-1836-7	151 lbs	CL20G-75-1836-7	124 lbs	CL18G-87-1836-7	173 lbs	CL20G-87-1836-7	146 lbs	CL18G-99-1836-7	175 lbs	CL20G-99-1836-7	148 lbs
24" x 36"	CL18G-75-2436-7	182 lbs	CL20G-75-2436-7	151 lbs	CL18G-87-2436-7	206 lbs	CL20G-87-2436-7	173 lbs	CL18G-99-2436-7	207 lbs	CL20G-99-2436-7	175 lbs
30" x 36"	CL18G-75-3036-7	208 lbs	CL20G-75-3036-7	171 lbs	CL18G-87-3036-7	234 lbs	CL20G-87-3036-7	197 lbs	CL18G-99-3036-7	236 lbs	CL20G-99-3036-7	199 lbs
12" x 42"	CL18G-75-1242-7	136 lbs	CL20G-75-1242-7	120 lbs	CL18G-87-1242-7	156 lbs	CL20G-87-1242-7	140 lbs	CL18G-99-1242-7	158 lbs	CL20G-99-1242-7	142 lbs
15" x 42"	CL18G-75-1542-7	150 lbs	CL20G-75-1542-7	123 lbs	CL18G-87-1542-7	171 lbs	CL20G-87-1542-7	144 lbs	CL18G-99-1542-7	173 lbs	CL20G-99-1542-7	146 lbs
18" x 42"	CL18G-75-1842-7	166 lbs	CL20G-75-1842-7	136 lbs	CL18G-87-1842-7	189 lbs	CL20G-87-1842-7	159 lbs	CL18G-99-1842-7	191 lbs	CL20G-99-1842-7	161 lbs
24" x 42"	CL18G-75-2442-7	203 lbs	CL20G-75-2442-7	161 lbs	CL18G-87-2442-7	229 lbs	CL20G-87-2442-7	187 lbs	CL18G-99-2442-7	231 lbs	CL20G-99-2442-7	189 lbs
30" x 42"	CL18G-75-3042-7	235 lbs	CL20G-75-3042-7	182 lbs	CL18G-87-3042-7	264 lbs	CL20G-87-3042-7	211 lbs	CL18G-99-3042-7	266 lbs	CL20G-99-3042-7	213 lbs
12" x 48"	CL18G-75-1248-7	153 lbs	CL20G-75-1248-7	135 lbs	CL18G-87-1248-7	177 lbs	CL20G-87-1248-7	159 lbs	CL18G-99-1248-7	179 lbs	CL20G-99-1248-7	161 lbs
15" x 48"	CL18G-75-1548-7	168 lbs	CL20G-75-1548-7	140 lbs	CL18G-87-1548-7	193 lbs	CL20G-87-1548-7	165 lbs	CL18G-99-1548-7	195 lbs	CL20G-99-1548-7	167 lbs
18" x 48"	CL18G-75-1848-7	184 lbs	CL20G-75-1848-7	151 lbs	CL18G-87-1848-7	210 lbs	CL20G-87-1848-7	177 lbs	CL18G-99-1848-7	212 lbs	CL20G-99-1848-7	179 lbs
24" x 48"	CL18G-75-2448-7	225 lbs	CL20G-75-2448-7	181 lbs	CL18G-87-2448-7	254 lbs	CL20G-87-2448-7	210 lbs	CL18G-99-2448-7	256 lbs	CL20G-99-2448-7	212 lbs
30" x 48"	CL18G-75-3048-7	259 lbs	CL20G-75-3048-7	210 lbs	CL18G-87-3048-7	289 lbs	CL20G-87-3048-7	241 lbs	CL18G-99-3048-7	291 lbs	CL20G-99-3048-7	243 lbs

IRONMAN 18 & 20 GAUGE CLOSED STEEL SHELVING

IRONMAN 18 & 20 Gauge Steel Closed Shelving - Add-On Units

Quantum's IRONMAN Closed Shelving Units are ideal for industrial and commercial storage and organization. Closed shelving provides extra protection from dirt & dust, creates separation between areas and prevents product from falling off sides or back of unit. Units are available in 18 & 20 gauge, 4 heights and 15 shelf sizes. Each add-on unit includes 2 offset posts (punched on 1" centers for easy adjustment), one beaded post, one back panel, one side panel and selected number of shelves with corresponding hardware (nuts and bolts for top and bottom shelves, clips for intermediate shelves). See shelf chart on page 78 for load weight capacity. Easy and quick assembly. Available in Gray.

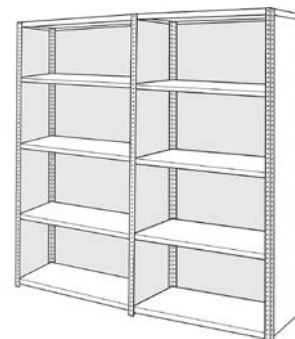

20G-75-1836-5 + AD20G-75-1836-5

**CLIP SHELVES MAKE FOR EASY
BOLT-FREE ASSEMBLY AND ADJUSTMENT**

IRONMAN Shelf Clips

Compression clip hardware can be used with our offset and beaded posts in combination with our steel shelves. Clips should be used for intermediate shelves only. Sold in packages of 4. (Note: One package required per shelf)



MODEL NO.	SHIP WGT
Shelf Clips	
OP-CC	1 lb



SHELF D" x W"	39"H			
	18 GAUGE		20 GAUGE	
MODEL NO.	SHIP WGT	MODEL NO.	SHIP WGT	
4 Shelf, 39"H Closed Shelving Unit				
12" x 36"	ADCL18G-39-1236-4	52 lbs	ADCL20G-39-1236-4	47 lbs
15" x 36"	ADCL18G-39-1536-4	64 lbs	ADCL20G-39-1536-4	51 lbs
18" x 36"	ADCL18G-39-1836-4	71 lbs	ADCL20G-39-1836-4	56 lbs
24" x 36"	ADCL18G-39-2436-4	87 lbs	ADCL20G-39-2436-4	69 lbs
30" x 36"	ADCL18G-39-3036-4	102 lbs	ADCL20G-39-3036-4	80 lbs
12" x 42"	ADCL18G-39-1242-4	63 lbs	ADCL20G-39-1242-4	55 lbs
15" x 42"	ADCL18G-39-1542-4	68 lbs	ADCL20G-39-1542-4	59 lbs
18" x 42"	ADCL18G-39-1842-4	82 lbs	ADCL20G-39-1842-4	63 lbs
24" x 42"	ADCL18G-39-2442-4	99 lbs	ADCL20G-39-2442-4	75 lbs
30" x 42"	ADCL18G-39-3042-4	115 lbs	ADCL20G-39-3042-4	85 lbs
12" x 48"	ADCL18G-39-1248-4	71 lbs	ADCL20G-39-1248-4	59 lbs
15" x 48"	ADCL18G-39-1548-4	80 lbs	ADCL20G-39-1548-4	63 lbs
18" x 48"	ADCL18G-39-1848-4	89 lbs	ADCL20G-39-1848-4	71 lbs
24" x 48"	ADCL18G-39-2448-4	109 lbs	ADCL20G-39-2448-4	84 lbs
30" x 48"	ADCL18G-39-3048-4	127 lbs	ADCL20G-39-3048-4	99 lbs
5 Shelf, 39"H Closed Shelving Unit				
12" x 36"	ADCL18G-39-1236-5	60 lbs	ADCL20G-39-1236-5	54 lbs
15" x 36"	ADCL18G-39-1536-5	75 lbs	ADCL20G-39-1536-5	58 lbs
18" x 36"	ADCL18G-39-1836-5	84 lbs	ADCL20G-39-1836-5	64 lbs
24" x 36"	ADCL18G-39-2436-5	103 lbs	ADCL20G-39-2436-5	80 lbs
30" x 36"	ADCL18G-39-3036-5	121 lbs	ADCL20G-39-3036-5	94 lbs
12" x 42"	ADCL18G-39-1242-5	73 lbs	ADCL20G-39-1242-5	63 lbs
15" x 42"	ADCL18G-39-1542-5	68 lbs	ADCL20G-39-1542-5	67 lbs
18" x 42"	ADCL18G-39-1842-5	96 lbs	ADCL20G-39-1842-5	73 lbs
24" x 42"	ADCL18G-39-2442-5	117 lbs	ADCL20G-39-2442-5	86 lbs
30" x 42"	ADCL18G-39-3042-5	137 lbs	ADCL20G-39-3042-5	99 lbs
12" x 48"	ADCL18G-39-1248-5	83 lbs	ADCL20G-39-1248-5	68 lbs
15" x 48"	ADCL18G-39-1548-5	94 lbs	ADCL20G-39-1548-5	73 lbs
18" x 48"	ADCL18G-39-1848-5	105 lbs	ADCL20G-39-1848-5	82 lbs
24" x 48"	ADCL18G-39-2448-5	129 lbs	ADCL20G-39-2448-5	98 lbs
30" x 48"	ADCL18G-39-3048-5	152 lbs	ADCL20G-39-3048-5	117 lbs
6 Shelf, 39"H Closed Shelving Unit				
12" x 36"	ADCL18G-39-1236-6	68 lbs	ADCL20G-39-1236-6	61 lbs
15" x 36"	ADCL18G-39-1536-6	86 lbs	ADCL20G-39-1536-6	65 lbs
18" x 36"	ADCL18G-39-1836-6	96 lbs	ADCL20G-39-1836-6	72 lbs
24" x 36"	ADCL18G-39-2436-6	119 lbs	ADCL20G-39-2436-6	91 lbs
30" x 36"	ADCL18G-39-3036-6	140 lbs	ADCL20G-39-3036-6	108 lbs
12" x 42"	ADCL18G-39-1242-6	83 lbs	ADCL20G-39-1242-6	71 lbs
15" x 42"	ADCL18G-39-1542-6	88 lbs	ADCL20G-39-1542-6	75 lbs
18" x 42"	ADCL18G-39-1842-6	110 lbs	ADCL20G-39-1842-6	73 lbs
24" x 42"	ADCL18G-39-2442-6	135 lbs	ADCL20G-39-2442-6	97 lbs
30" x 42"	ADCL18G-39-3042-6	159 lbs	ADCL20G-39-3042-6	113 lbs
12" x 48"	ADCL18G-39-1248-6	95 lbs	ADCL20G-39-1248-6	77 lbs
15" x 48"	ADCL18G-39-1548-6	108 lbs	ADCL20G-39-1548-6	73 lbs
18" x 48"	ADCL18G-39-1848-6	121 lbs	ADCL20G-39-1848-6	93 lbs
24" x 48"	ADCL18G-39-2448-6	149 lbs	ADCL20G-39-2448-6	112 lbs
30" x 48"	ADCL18G-39-3048-6	177 lbs	ADCL20G-39-3048-6	134 lbs

CLOSED STEEL SHELVING - ADD-ON UNITS

- Provides extra protection against dirt and dust
- Creates separation between areas
- Clip shelves make for easy bolt-free assembly and adjustment
- Shelves are adjustable on 1" increments
- Panels on side and back provide stability



Additional Shelves and Clips available, see components pages 78 & 84.
22 Gauge Shelving also available in three different sizes, see page 86.

SHELF D" x W"	75"H				87"H				99"H			
	18 GAUGE		20 GAUGE		18 GAUGE		20 GAUGE		18 GAUGE		20 GAUGE	
	MODEL NO.	SHIP WGT	MODEL NO.	SHIP WGT	MODEL NO.	SHIP WGT	MODEL NO.	SHIP WGT	MODEL NO.	SHIP WGT	MODEL NO.	SHIP WGT
5 Shelf, 75"H Closed Shelving Unit				5 Shelf, 87"H Closed Shelving Unit				5 Shelf, 99"H Closed Shelving Unit				
12" x 36"	ADCL18G-75-1236-5	85 lbs	ADCL20G-75-1236-5	65 lbs	ADCL18G-87-1236-5	99 lbs	ADCL20G-87-1236-5	67 lbs	ADCL18G-99-1236-5	100 lbs	ADCL20G-99-1236-5	68 lbs
15" x 36"	ADCL18G-75-1536-5	99 lbs	ADCL20G-75-1536-5	69 lbs	ADCL18G-87-1536-5	114 lbs	ADCL20G-87-1536-5	71 lbs	ADCL18G-99-1536-5	115 lbs	ADCL20G-99-1536-5	72 lbs
18" x 36"	ADCL18G-75-1836-5	109 lbs	ADCL20G-75-1836-5	76 lbs	ADCL18G-87-1836-5	125 lbs	ADCL20G-87-1836-5	78 lbs	ADCL18G-99-1836-5	126 lbs	ADCL20G-99-1836-5	79 lbs
24" x 36"	ADCL18G-75-2436-5	131 lbs	ADCL20G-75-2436-5	93 lbs	ADCL18G-87-2436-5	148 lbs	ADCL20G-87-2436-5	95 lbs	ADCL18G-99-2436-5	149 lbs	ADCL20G-99-2436-5	96 lbs
30" x 36"	ADCL18G-75-3036-5	149 lbs	ADCL20G-75-3036-5	106 lbs	ADCL18G-87-3036-5	167 lbs	ADCL20G-87-3036-5	108 lbs	ADCL18G-99-3036-5	168 lbs	ADCL20G-99-3036-5	109 lbs
12" x 42"	ADCL18G-75-1242-5	101 lbs	ADCL20G-75-1242-5	75 lbs	ADCL18G-87-1242-5	117 lbs	ADCL20G-87-1242-5	78 lbs	ADCL18G-99-1242-5	118 lbs	ADCL20G-99-1242-5	79 lbs
15" x 42"	ADCL18G-75-1542-5	112 lbs	ADCL20G-75-1542-5	78 lbs	ADCL18G-87-1542-5	129 lbs	ADCL20G-87-1542-5	80 lbs	ADCL18G-99-1542-5	130 lbs	ADCL20G-99-1542-5	81 lbs
18" x 42"	ADCL18G-75-1842-5	123 lbs	ADCL20G-75-1842-5	86 lbs	ADCL18G-87-1842-5	141 lbs	ADCL20G-87-1842-5	87 lbs	ADCL18G-99-1842-5	142 lbs	ADCL20G-99-1842-5	88 lbs
24" x 42"	ADCL18G-75-2442-5	148 lbs	ADCL20G-75-2442-5	101 lbs	ADCL18G-87-2442-5	166 lbs	ADCL20G-87-2442-5	102 lbs	ADCL18G-99-2442-5	167 lbs	ADCL20G-99-2442-5	103 lbs
30" x 42"	ADCL18G-75-3042-5	168 lbs	ADCL20G-75-3042-5	112 lbs	ADCL18G-87-3042-5	188 lbs	ADCL20G-87-3042-5	115 lbs	ADCL18G-99-3042-5	189 lbs	ADCL20G-99-3042-5	115 lbs
12" x 48"	ADCL18G-75-1248-5	110 lbs	ADCL20G-75-1248-5	97 lbs	ADCL18G-87-1248-5	127 lbs	ADCL20G-87-1248-5	114 lbs	ADCL18G-99-1248-5	128 lbs	ADCL20G-99-1248-5	116 lbs
15" x 48"	ADCL18G-75-1548-5	122 lbs	ADCL20G-75-1548-5	102 lbs	ADCL18G-87-1548-5	139 lbs	ADCL20G-87-1548-5	118 lbs	ADCL18G-99-1548-5	140 lbs	ADCL20G-99-1548-5	120 lbs
18" x 48"	ADCL18G-75-1848-5	133 lbs	ADCL20G-75-1848-5	109 lbs	ADCL18G-87-1848-5	152 lbs	ADCL20G-87-1848-5	128 lbs	ADCL18G-99-1848-5	153 lbs	ADCL20G-99-1848-5	129 lbs
24" x 48"	ADCL18G-75-2448-5	161 lbs	ADCL20G-75-2448-5	130 lbs	ADCL18G-87-2448-5	181 lbs	ADCL20G-87-2448-5	149 lbs	ADCL18G-99-2448-5	182 lbs	ADCL20G-99-2448-5	150 lbs
30" x 48"	ADCL18G-75-3048-5	184 lbs	ADCL20G-75-3048-5	150 lbs	ADCL18G-87-3048-5	205 lbs	ADCL20G-87-3048-5	170 lbs	ADCL18G-99-3048-5	206 lbs	ADCL20G-99-3048-5	171 lbs
6 Shelf, 75"H Closed Shelving Unit				6 Shelf, 87"H Closed Shelving Unit				6 Shelf, 99"H Closed Shelving Unit				
12" x 36"	ADCL18G-75-1236-6	93 lbs	ADCL20G-75-1236-6	84 lbs	ADCL18G-87-1236-6	107 lbs	ADCL20G-87-1236-6	98 lbs	ADCL18G-99-1236-6	108 lbs	ADCL20G-99-1236-6	99 lbs
15" x 36"	ADCL18G-75-1536-6	110 lbs	ADCL20G-75-1536-6	90 lbs	ADCL18G-87-1536-6	125 lbs	ADCL20G-87-1536-6	105 lbs	ADCL18G-99-1536-6	126 lbs	ADCL20G-99-1536-6	106 lbs
18" x 36"	ADCL18G-75-1836-6	121 lbs	ADCL20G-75-1836-6	97 lbs	ADCL18G-87-1836-6	138 lbs	ADCL20G-87-1836-6	114 lbs	ADCL18G-99-1836-6	139 lbs	ADCL20G-99-1836-6	115 lbs
24" x 36"	ADCL18G-75-2436-6	147 lbs	ADCL20G-75-2436-6	119 lbs	ADCL18G-87-2436-6	164 lbs	ADCL20G-87-2436-6	136 lbs	ADCL18G-99-2436-6	165 lbs	ADCL20G-99-2436-6	137 lbs
30" x 36"	ADCL18G-75-3036-6	168 lbs	ADCL20G-75-3036-6	136 lbs	ADCL18G-87-3036-6	186 lbs	ADCL20G-87-3036-6	154 lbs	ADCL18G-99-3036-6	187 lbs	ADCL20G-99-3036-6	155 lbs
12" x 42"	ADCL18G-75-1242-6	112 lbs	ADCL20G-75-1242-6	98 lbs	ADCL18G-87-1242-6	128 lbs	ADCL20G-87-1242-6	114 lbs	ADCL18G-99-1242-6	129 lbs	ADCL20G-99-1242-6	115 lbs
15" x 42"	ADCL18G-75-1542-6	124 lbs	ADCL20G-75-1542-6	102 lbs	ADCL18G-87-1542-6	141 lbs	ADCL20G-87-1542-6	118 lbs	ADCL18G-99-1542-6	142 lbs	ADCL20G-99-1542-6	119 lbs
18" x 42"	ADCL18G-75-1842-6	136 lbs	ADCL20G-75-1842-6	110 lbs	ADCL18G-87-1842-6	155 lbs	ADCL20G-87-1842-6	129 lbs	ADCL18G-99-1842-6	156 lbs	ADCL20G-99-1842-6	130 lbs
24" x 42"	ADCL18G-75-2442-6	166 lbs	ADCL20G-75-2442-6	130 lbs	ADCL18G-87-2442-6	185 lbs	ADCL20G-87-2442-6	149 lbs	ADCL18G-99-2442-6	186 lbs	ADCL20G-99-2442-6	150 lbs
30" x 42"	ADCL18G-75-3042-6	190 lbs	ADCL20G-75-3042-6	144 lbs	ADCL18G-87-3042-6	210 lbs	ADCL20G-87-3042-6	164 lbs	ADCL18G-99-3042-6	211 lbs	ADCL20G-99-3042-6	165 lbs
12" x 48"	ADCL18G-75-1248-6	122 lbs	ADCL20G-75-1248-6	106 lbs	ADCL18G-87-1248-6	139 lbs	ADCL20G-87-1248-6	123 lbs	ADCL18G-99-1248-6	140 lbs	ADCL20G-99-1248-6	124 lbs
15" x 48"	ADCL18G-75-1548-6	135 lbs	ADCL20G-75-1548-6	111 lbs	ADCL18G-87-1548-6	153 lbs	ADCL20G-87-1548-6	129 lbs	ADCL18G-99-1548-6	154 lbs	ADCL20G-99-1548-6	130 lbs
18" x 48"	ADCL18G-75-1848-6	149 lbs	ADCL20G-75-1848-6	121 lbs	ADCL18G-87-1848-6	168 lbs	ADCL20G-87-1848-6	139 lbs	ADCL18G-99-1848-6	169 lbs	ADCL20G-99-1848-6	140 lbs
24" x 48"	ADCL18G-75-2448-6	182 lbs	ADCL20G-75-2448-6	144 lbs	ADCL18G-87-2448-6	201 lbs	ADCL20G-87-2448-6	164 lbs	ADCL18G-99-2448-6	202 lbs	ADCL20G-99-2448-6	165 lbs
30" x 48"	ADCL18G-75-3048-6	209 lbs	ADCL20G-75-3048-6	167 lbs	ADCL18G-87-3048-6	230 lbs	ADCL20G-87-3048-6	188 lbs	ADCL18G-99-3048-6	231 lbs	ADCL20G-99-3048-6	189 lbs
7 Shelf, 75"H Closed Shelving Unit				7 Shelf, 87"H Closed Shelving Unit				7 Shelf, 99"H Closed Shelving Unit				
12" x 36"	ADCL18G-75-1236-7	102 lbs	ADCL20G-75-1236-7	91 lbs	ADCL18G-87-1236-7	115 lbs	ADCL20G-87-1236-7	105 lbs	ADCL18G-99-1236-7	116 lbs	ADCL20G-99-1236-7	106 lbs
15" x 36"	ADCL18G-75-1536-7	121 lbs	ADCL20G-75-1536-7	97 lbs	ADCL18G-87-1536-7	136 lbs	ADCL20G-87-1536-7	112 lbs	ADCL18G-99-1536-7	137 lbs	ADCL20G-99-1536-7	113 lbs
18" x 36"	ADCL18G-75-1836-7	134 lbs	ADCL20G-75-1836-7	107 lbs	ADCL18G-87-1836-7	150 lbs	ADCL20G-87-1836-7	123 lbs	ADCL18G-99-1836-7	151 lbs	ADCL20G-99-1836-7	124 lbs
24" x 36"	ADCL18G-75-2436-7	163 lbs	ADCL20G-75-2436-7	132 lbs	ADCL18G-87-2436-7	180 lbs	ADCL20G-87-2436-7	147 lbs	ADCL18G-99-2436-7	180 lbs	ADCL20G-99-2436-7	148 lbs
30" x 36"	ADCL18G-75-3036-7	187 lbs	ADCL20G-75-3036-7	150 lbs	ADCL18G-87-3036-7	205 lbs	ADCL20G-87-3036-7	168 lbs	ADCL18G-99-3036-7	206 lbs	ADCL20G-99-3036-7	169 lbs
12" x 42"	ADCL18G-75-1242-7	123 lbs	ADCL20G-75-1242-7	107 lbs	ADCL18G-87-1242-7	139 lbs	ADCL20G-87-1242-7	123 lbs	ADCL18G-99-1242-7	140 lbs	ADCL20G-99-1242-7	124 lbs
15" x 42"	ADCL18G-75-1542-7	137 lbs	ADCL20G-75-1542-7	110 lbs	ADCL18G-87-1542-7	154 lbs	ADCL20G-87-1542-7	127 lbs	ADCL18G-99-1542-7	155 lbs	ADCL20G-99-1542-7	128 lbs
18" x 42"	ADCL18G-75-1842-7	151 lbs	ADCL20G-75-1842-7	121 lbs	ADCL18G-87-1842-7	169 lbs	ADCL20G-87-1842-7	139 lbs	ADCL18G-99-1842-7	170 lbs	ADCL20G-99-1842-7	140 lbs
24" x 42"	ADCL18G-75-2442-7	184 lbs	ADCL20G-75-2442-7	142 lbs	ADCL18G-87-2442-7	203 lbs	ADCL20G-87-2442-7	161 lbs	ADCL18G-99-2442-7	204 lbs	ADCL20G-99-2442-7	162 lbs
30" x 42"	ADCL18G-75-3042-7	212 lbs	ADCL20G-75-3042-7	159 lbs	ADCL18G-87-3042-7	232 lbs	ADCL20G-87-3042-7	179 lbs	ADCL18G-99-3042-7	233 lbs	ADCL20G-99-3042-7	180 lbs
12" x 48"	ADCL18G-75-1248-7	134 lbs	ADCL20G-75-1248-7	116 lbs	ADCL18G-87-1248-7	151 lbs	ADCL20G-87-1248-7	133 lbs	ADCL18G-99-1248-7	152 lbs	ADCL20G-99-1248-7	134 lbs
15" x 48"	ADCL18G-75-1548-7	149 lbs	ADCL20G-75-1548-7	121 lbs	ADCL18G-87-1548-7	167 lbs	ADCL20G-87-1548-7	139 lbs	ADCL18G-99-1548-7	168 lbs	ADCL20G-99-1548-7	140 lbs
18" x 48"	ADCL18G-75-1848-7	160 lbs	ADCL20G-75-1848-7	132 lbs	ADCL18G-87-1848-7	184 lbs	ADCL20G-87-1848-7	151 lbs	ADCL18G-99-1848-7	185 lbs	ADCL20G-99-1848-7	152 lbs
24" x 48"	ADCL18G-75-2448-7	202 lbs	ADCL20G-75-2448-7	158 lbs	ADCL18G-87-2448-7	222 lbs	ADCL20G-87-2448-7	178 lbs	ADCL18G-99-2448-7	223 lbs	ADCL20G-99-2448-7	179 lbs
30" x 48"	ADCL18G-75-3048-7	234 lbs	ADCL20G-75-3048-7	185 lbs	ADCL18G-87-3048-7	254 lbs	ADCL20G-87-3048-7	206 lbs	ADCL18G-99-3048-7	255 lbs	ADCL20G-99-3048-7	207 lbs

IRONMAN 22 GAUGE STEEL SHELVING



OPEN SHELVING
75-1836-6

IRONMAN Steel Shelving

- Heavy-duty, high grade shelving units are easy to clean and will not rust or corrode
- Shelving Units are 39"H or 75"H and are available in three different shelf sizes
- Shelving has a smooth powder coat finish
- 400 lb. shelf capacity

Open Steel Shelving

MODEL NO.	SHELF D" x W"	SHIP WGT
4 Shelf, 39"H Open Shelving Unit		
39-1236-4	12" x 36"	45 lbs
39-1836-4	18" x 36"	63 lbs
39-1842-4	18" x 42"	71 lbs
5 Shelf, 39"H Open Shelving Unit		
39-1236-5	12" x 36"	53 lbs
39-1836-5	18" x 36"	75 lbs
39-1842-5	18" x 42"	85 lbs
6 Shelf, 39"H Open Shelving Unit		
39-1236-6	12" x 36"	61 lbs
39-1836-6	18" x 36"	87 lbs
39-1842-6	18" x 42"	99 lbs

MODEL NO.	SHELF D" x W"	SHIP WGT
4 Shelf, 75"H Open Shelving Unit		
75-1236-4	12" x 36"	55 lbs
75-1836-4	18" x 36"	69 lbs
75-1842-4	18" x 42"	85 lbs
5 Shelf, 75"H Open Shelving Unit		
75-1236-5	12" x 36"	66 lbs
75-1836-5	18" x 36"	79 lbs
75-1842-5	18" x 42"	91 lbs
6 Shelf, 75"H Open Shelving Unit		
75-1236-6	12" x 36"	73 lbs
75-1836-6	18" x 36"	89 lbs
75-1842-6	18" x 42"	101 lbs
7 Shelf, 75"H Open Shelving Unit		
75-1236-7	12" x 36"	80 lbs
75-1836-7	18" x 36"	99 lbs
75-1842-7	18" x 42"	113 lbs
8 Shelf, 75"H Open Shelving Unit		
75-1236-8	12" x 36"	87 lbs
75-1836-8	18" x 36"	109 lbs
75-1842-8	18" x 42"	125 lbs



CLOSED SHELVING
CL75-1836-6

Closed Shelving DUST FREE & SECURE Storage!

Closed Steel Shelving

MODEL NO.	SHELF D" x W"	SHIP WGT
4 Shelf, 39"H Closed Shelving Unit		
CL39-1236-4	12" x 36"	71 lbs
CL39-1836-4	18" x 36"	94 lbs
CL39-1842-4	18" x 42"	104 lbs
5 Shelf, 39"H Closed Shelving Unit		
CL39-1236-5	12" x 36"	79 lbs
CL39-1836-5	18" x 36"	106 lbs
CL39-1842-5	18" x 42"	118 lbs
6 Shelf, 39"H Closed Shelving Unit		
CL39-1236-6	12" x 36"	87 lbs
CL39-1836-6	18" x 36"	118 lbs
CL39-1842-6	18" x 42"	132 lbs

MODEL NO.	SHELF D" x W"	SHIP WGT
4 Shelf, 75"H Closed Shelving Unit		
CL75-1236-4	12" x 36"	90 lbs
CL75-1836-4	18" x 36"	115 lbs
5 Shelf, 75"H Closed Shelving Unit		
CL75-1236-5	12" x 36"	103 lbs
CL75-1836-5	18" x 36"	126 lbs
6 Shelf, 75"H Closed Shelving Unit		
CL75-1236-6	12" x 36"	110 lbs
CL75-1836-6	18" x 36"	136 lbs
7 Shelf, 75"H Closed Shelving Unit		
CL75-1236-7	12" x 36"	117 lbs
CL75-1836-7	18" x 36"	146 lbs
8 Shelf, 75"H Closed Shelving Unit		
CL75-1236-8	12" x 36"	124 lbs
CL75-1836-8	18" x 36"	156 lbs



WIRE SHELVING

Wire Shelving System Finishes

Genuine Quantum modular wire systems offer a unique combination of shelf and post sizes in a variety of finishes to compliment any application. The split sleeve and grooved numbered posts allow for easy and quick assembly. The all welded shelf construction is supported with architectural wire trusses to provide between 600 lb. and 800 lb. capacity per shelf.

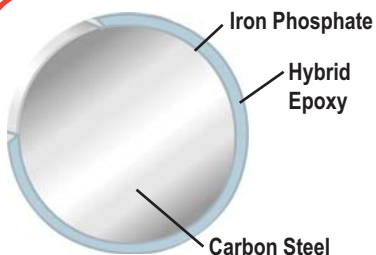

Proform - is an economical solution for high humidity or wet applications. The carbon steel is treated with an iron phosphate base. A hybrid epoxy with an antibacterial agent is electrostatically applied over the treated surface. Color: Light Green

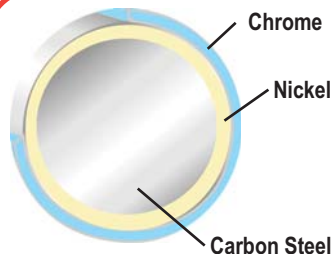
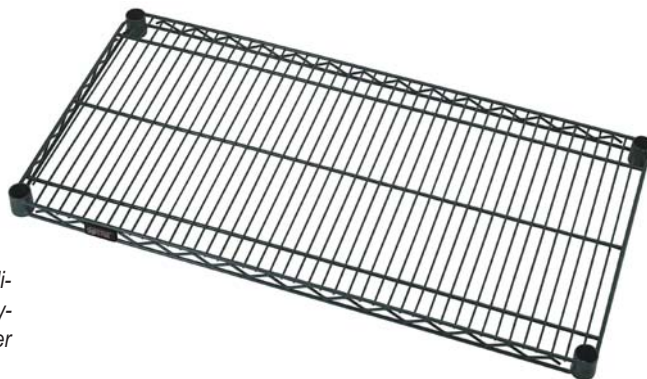

Chrome - is a plating process which deposits hard chrome over a nickel surface. This process is very durable and is used in an up-front storage or material handling application in any dry storage environment.

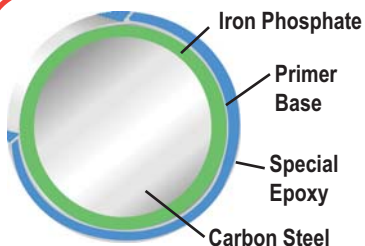
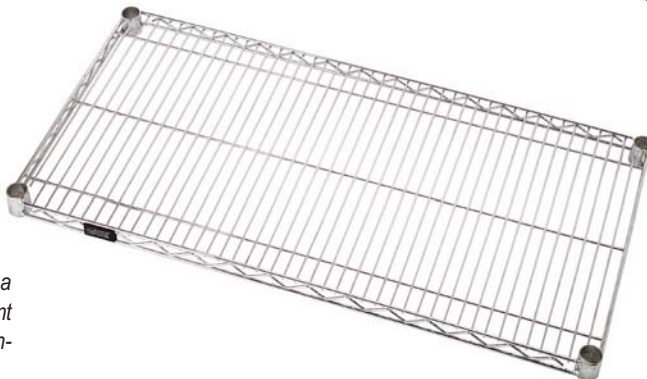

Endurance - is a newly developed process which exceeds conventional finishes with a lifetime warranty. Finish is excellent for high humidity or corrosive applications and is fortified with an anti-bacterial agent. Color: Blue

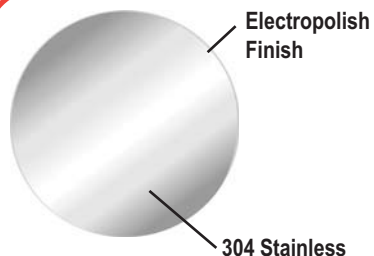
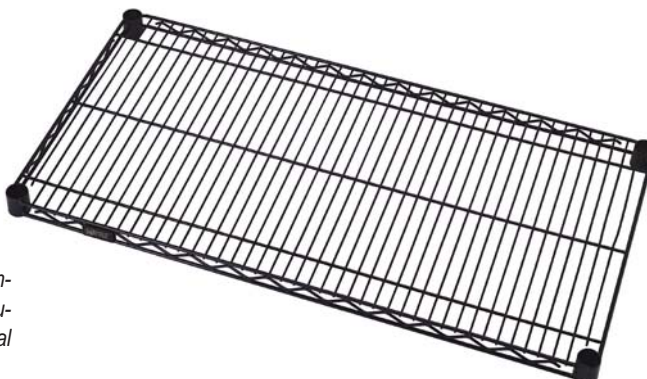

Stainless Steel - 304 Stainless with an electropolish finish represents the highest industry standard in the prevention of corrosion. This finish is highly effective for corrosive or clean room environments.

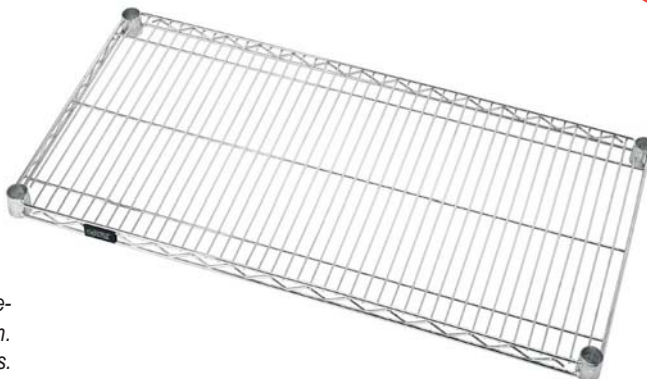

WIRE SHELVES

Performance Features

- All welded construction with additional wire trussing for high strength characteristics
- Top mat wires run front to back (**except on 12" x 36" size**) for ease of loading and unloading
- Wire allows air to circulate and light to penetrate for increased product visibility
- Minimal dirt accumulation
- Split conical sleeve adaptors secure shelf corner to post

- Numbered grooved posts on 1 inch increments for quick assembly
- No tools required for assembly
- Adjustable foot levelers
- Durable finishes
- Aesthetically pleasing
- Optional accessories
- Applicable for Industrial, Healthcare, Food Service and Retail Markets
- National Sanitation Foundation (NSF) Approved
- Shipped KD Class 70
- 600 to 800 lb. capacity per shelf

SHELF W" x L"	SHIP WGT	CHROME	STAINLESS STEEL	PROFORM	ENDURANCE
		MODEL NO.	MODEL NO.	MODEL NO.	MODEL NO.
12" Deep Wire Shelves					
12" x 24"	6 lbs	1224C	--	--	--
12" x 30"	6 lbs	1230C	--	--	--
12" x 36"	7 lbs	1236C	--	--	1236E*
12" x 42"	8 lbs	1242C	--	--	1242E*
12" x 48"	9 lbs	1248C	--	--	1248E*
12" x 60"	14 lbs	1260C	--	--	1260E*
12" x 72"	17 lbs	1272C	--	--	1272E*
14" Deep Wire Shelves					
14" x 24"	6 lbs	1424C	1424S*	1424P*	1424E*
14" x 30"	7 lbs	1430C	1430S*	1430P*	1430E*
14" x 36"	8 lbs	1436C	1436S*	1436P*	1436E*
14" x 42"	10 lbs	1442C	1442S*	1442P*	1442E*
14" x 48"	11 lbs	1448C	1448S*	1448P*	1448E*
14" x 54"	12 lbs	1454C	1454S*	1454P*	1454E*
14" x 60"	14 lbs	1460C	1460S*	1460P*	1460E*
14" x 72"	17 lbs	1472C	1472S*	1472P*	1472E*
18" Deep Wire Shelves					
18" x 24"	7 lbs	1824C	1824S*	1824P*	1824E*
18" x 30"	8 lbs	1830C	1830S*	1830P*	1830E*
18" x 36"	10 lbs	1836C	1836S*	1836P*	1836E*
18" x 42"	11 lbs	1842C	1842S*	1842P*	1842E*
18" x 48"	14 lbs	1848C	1848S*	1848P*	1848E*
18" x 54"	15 lbs	1854C	1854S*	1854P*	1854E*
18" x 60"	17 lbs	1860C	1860S*	1860P*	1860E*
18" x 72"	20 lbs	1872C	1872S*	1872P*	1872E*
21" Deep Wire Shelves					
21" x 24"	8 lbs	2124C	2124S*	2124P*	2124E*
21" x 30"	9 lbs	2130C	2130S*	2130P*	2130E*
21" x 36"	11 lbs	2136C	2136S*	2136P*	2136E*
21" x 42"	12 lbs	2142C	2142S*	2142P*	2142E*
21" x 48"	14 lbs	2148C	2148S*	2148P*	2148E*
21" x 54"	16 lbs	2154C	2154S*	2154P*	2154E*
21" x 60"	18 lbs	2160C	2160S*	2160P*	2160E*
21" x 72"	24 lbs	2172C	2172S*	2172P*	2172E*
24" Deep Wire Shelves					
24" x 24"	9 lbs	2424C	2424S*	2424P*	2424E*
24" x 30"	11 lbs	2430C	2430S*	2430P*	2430E*
24" x 36"	13 lbs	2436C	2436S*	2436P*	2436E*
24" x 42"	15 lbs	2442C	2442S*	2442P*	2442E*
24" x 48"	16 lbs	2448C	2448S*	2448P*	2448E*
24" x 54"	18 lbs	2454C	2454S*	2454P*	2454E*
24" x 60"	21 lbs	2460C	2460S*	2460P*	2460E*
24" x 66"	23 lbs	2466C	--	2466P*	--
24" x 72"	26 lbs	2472C	2472S*	2472P*	2472E*
30" Deep Wire Shelves					
30" x 36"	15 lbs	3036C	--	--	3036E*
30" x 42"	18 lbs	3042C	--	--	3042E*
30" x 48"	21 lbs	3048C	--	--	3048E*
30" x 60"	27 lbs	3060C	--	--	3060E*
30" x 72"	31 lbs	3072C	--	--	3072E*
36" Deep Wire Shelves					
36" x 36"	18 lbs	3636C	--	--	3636E*
36" x 48"	23 lbs	3648C	--	--	3648E*
36" x 60"	29 lbs	3660C	--	--	3660E*
36" x 72"	35 lbs	3672C	--	--	3672E*



Chrome Finish



Proform Finish



* Special order. Minimum quantity and extended lead time may apply. Please call for details.

WIRE SHELVING POSTS / SOLID SHELVES

Posts

All posts are fabricated from 16 gauge carbon steel with location grooves on one inch increments and ease for shelf installation. Numbers are printed between grooves for quick assembly. Posts are double grooved in consistent intervals for quick identification. Leveling legs are enclosed with all posts. Leveling legs cannot be used in conjunction with stem casters. See page 123 to order caster sets. Custom post heights are available, call for pricing.

		CHROME	STAINLESS STEEL	PROFORM	ENDURANCE
DESCRIPTION	SHIP WGT	MODEL NO.	MODEL NO.	MODEL NO.	MODEL NO.
6"H Post	1 lb	P6C	P6S*	P6P*	P6E
14"H Post	1 lb	P14C	P14S*	P14P	P14E
34"H Post	2 lbs	P34C	P34S*	P34P	P34E
42"H Post	2 lbs	P42C*	P42S	P42P*	P42E*
54"H Post	3 lbs	P54C	P54S	P54P	P54E
63"H Post	4 lbs	P63C	P63S	P63P	P63E
74"H Post	4 lbs	P74C	P74S	P74P	P74E
86"H Post	5 lbs	P86C	P86S	P86P	P86E
96"H Post	6 lbs	P96C	P96S*	P96P*	P96E*

* Special order. Minimum quantity and extended lead time may apply. Please call for details.



Model No.: W-PLI

Post insert

Model No.: W-PLB

Post leveler adjusts up or down allowing height flexibility



1836SG



Solid Shelves

- Designed for storage of small parts that might normally fall through wire shelves
- Dual layer construction with double hemmed perimeter with marine edge ensures maximum strength while retaining spillage
- 18 gauge galvanized steel or 304 stainless steel
- Excellent corrosion resistance

		GALVANIZED STEEL	STAINLESS STEEL
DIMENSIONS W" x L"	SHIP WGT	MODEL NO.	MODEL NO.
18" x 36"	16 lbs	1836SG	1836SS
18" x 48"	20 lbs	1848SG	1848SS
18" x 60"	24 lbs	1860SG	1860SS
24" x 36"	19 lbs	2436SG	2436SS
24" x 48"	24 lbs	2448SG	2448SS
24" x 60"	31 lbs	2460SG	2460SS

Model No.: W-PC-STUD

Fully threaded stud connector can be utilized to connect two posts enabling any post height to be achieved



18 Gauge Galvanized or 304 Stainless Steel

LOWEST PRICE GUARANTEED!

Assembling WIRE SHELVING Units is as easy as 1 - 2 - 3...



1. Snap plastic sleeve around post.



2. Slide shelf over sleeve for secure locking.



3. Two "S-Hooks" are used to connect add-on wire shelf to starter units enabling post to be shared.

54" CHROME WIRE SHELVING SYSTEMS



Side to Side Unit

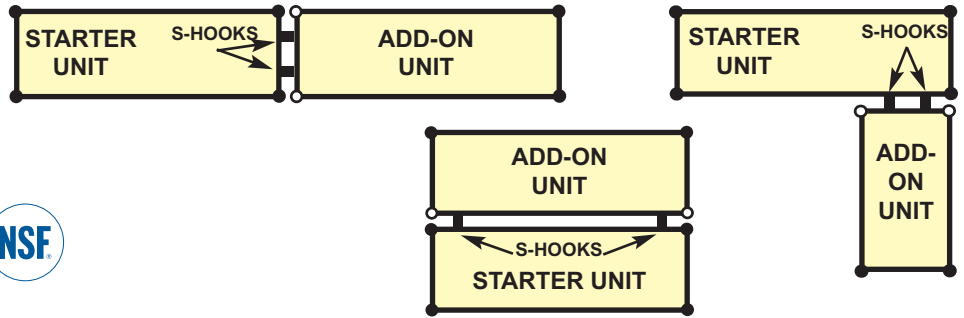

Starter Kits

Heavy-duty shelving unit allows up to 800 lb. shelf capacity. Starter kits come complete with 4 posts and 4 shelves. Additional shelves may be purchased separately. See chart on page 88. Mobilize starter kit shelving unit using optional mobile kit, WR-00 or WR-00H.



For continuous runs of shelving. Two hooks should be placed per shelf where two posts are not utilized.



Add-On Kits

Additional Add-On kit allows you to expand your Starter kit by sharing a set of posts. Configuration options include straight line, back to back and right angles (L-Shape). Add-On kits come complete with 2 posts, 4 shelves and 8 S-Hooks. Additional shelves and posts may be purchased separately. See chart on page 88. Units with Add-On kit cannot be made mobile.

SHELF W" x L"	54"H WIRE SHELVING STARTER KIT		54"H WIRE SHELVING ADD-ON KIT	
	CHROME MODEL NO.	SHIP WGT	CHROME MODEL NO.	SHIP WGT
12" x 36"	WR54-1236C	40 lbs	AD54-1236C	36 lbs
12" x 42"	WR54-1242C	44 lbs	AD54-1242C	40 lbs
12" x 48"	WR54-1248C	48 lbs	AD54-1248C	44 lbs
12" x 60"	WR54-1260C	56 lbs	AD54-1260C	52 lbs
12" x 72"	WR54-1272C	64 lbs	AD54-1272C	60 lbs
14" x 24"	WR54-1424C	36 lbs	AD54-1424C	32 lbs
14" x 30"	WR54-1430C	40 lbs	AD54-1430C	36 lbs
14" x 36"	WR54-1436C	44 lbs	AD54-1436C	40 lbs
14" x 42"	WR54-1442C	52 lbs	AD54-1442C	48 lbs
14" x 48"	WR54-1448C	56 lbs	AD54-1448C	52 lbs
14" x 54"	WR54-1454C	60 lbs	AD54-1454C	56 lbs
14" x 60"	WR54-1460C	68 lbs	AD54-1460C	64 lbs
14" x 72"	WR54-1472C	80 lbs	AD54-1472C	76 lbs
18" x 24"	WR54-1824C	40 lbs	AD54-1824C	36 lbs
18" x 30"	WR54-1830C	44 lbs	AD54-1830C	40 lbs
18" x 36"	WR54-1836C	52 lbs	AD54-1836C	48 lbs
18" x 42"	WR54-1842C	56 lbs	AD54-1842C	52 lbs
18" x 48"	WR54-1848C	60 lbs	AD54-1848C	56 lbs
18" x 54"	WR54-1854C	72 lbs	AD54-1854C	68 lbs
18" x 60"	WR54-1860C	80 lbs	AD54-1860C	76 lbs
18" x 72"	WR54-1872C	92 lbs	AD54-1872C	88 lbs
21" x 24"	WR54-2124C	44 lbs	AD54-2124C	40 lbs
21" x 30"	WR54-2130C	48 lbs	AD54-2130C	44 lbs
21" x 36"	WR54-2136C	56 lbs	AD54-2136C	52 lbs
21" x 42"	WR54-2142C	60 lbs	AD54-2142C	56 lbs
21" x 48"	WR54-2148C	68 lbs	AD54-2148C	64 lbs
21" x 54"	WR54-2154C	76 lbs	AD54-2154C	72 lbs
21" x 60"	WR54-2160C	84 lbs	AD54-2160C	88 lbs
21" x 72"	WR54-2172C	108 lbs	AD54-2172C	104 lbs
24" x 24"	WR54-2424C	48 lbs	AD54-2424C	44 lbs
24" x 30"	WR54-2430C	56 lbs	AD54-2430C	52 lbs
24" x 36"	WR54-2436C	64 lbs	AD54-2436C	60 lbs
24" x 42"	WR54-2442C	72 lbs	AD54-2442C	68 lbs
24" x 48"	WR54-2448C	76 lbs	AD54-2448C	72 lbs
24" x 54"	WR54-2454C	84 lbs	AD54-2454C	80 lbs
24" x 60"	WR54-2460C	96 lbs	AD54-2460C	92 lbs
24" x 72"	WR54-2472C	116 lbs	AD54-2472C	112 lbs
30" x 36"	WR54-3036C	72 lbs	AD54-3036C	68 lbs
30" x 42"	WR54-3042C	84 lbs	AD54-3042C	80 lbs
30" x 48"	WR54-3048C	96 lbs	AD54-3048C	92 lbs
30" x 60"	WR54-3060C	120 lbs	AD54-3060C	116 lbs
30" x 72"	WR54-3072C	136 lbs	AD54-3072C	132 lbs
36" x 36"	WR54-3636C	84 lbs	AD54-3636C	80 lbs
36" x 48"	WR54-3648C	104 lbs	AD54-3648C	100 lbs
36" x 60"	WR54-3660C	128 lbs	AD54-3660C	124 lbs
36" x 72"	WR54-3672C	136 lbs	AD54-3672C	132 lbs

Shelving units include 4 posts and 4 shelves. Add-On units include 2 posts, 4 shelves and 8 S-Hooks.



63" CHROME WIRE SHELVING SYSTEMS



Back to Back Unit

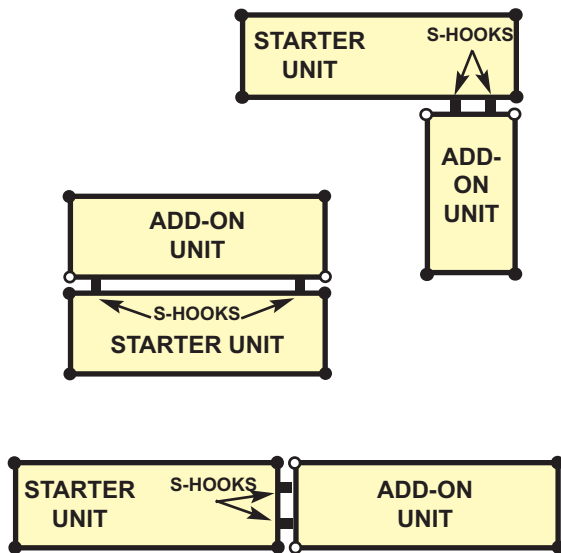

MOBILIZE YOUR WIRE SHELVING



DB - Donut Bumper
Non-marking donut bumper used to protect walls and help cushion impact.

WR-00H (Mobile Kit)*
Set of four swivel polyurethane 5" x 1-1/4" casters, two with brakes. Can be used with all units shown. 1,200 lb. load capacity.
*Mobile kits recommended only for shelves 18" and wider



LOWEST PRICE GUARANTEED!

Starter Kits

Heavy-duty shelving unit allows up to 800 lb. shelf capacity. Starter kits come complete with 4 posts and 4 shelves. Additional shelves may be purchased separately. See chart on page 88. Mobilize starter shelving unit using optional mobile kit, WR-00 or WR-00H available on page 123.

Add-On Kits

Additional Add-On kit allows you to expand your Starter kit by sharing a set of posts. Configuration options include straight line, back to back and right angles (L-Shape). Add-On kits come complete with 2 posts, 4 shelves and 8 S-Hooks. Additional shelves may be purchased separately. See chart on page 88. Units with Add-On kit cannot be made mobile.

	63"H WIRE SHELVING STARTER KIT		63"H WIRE SHELVING ADD-ON KIT	
SHELF W" x L"	CHROME MODEL NO.	SHIP WGT	CHROME MODEL NO.	SHIP WGT
12" x 36"	WR63-1236C	42 lbs	AD63-1236C	37 lbs
12" x 42"	WR63-1242C	46 lbs	AD63-1242C	41 lbs
12" x 48"	WR63-1248C	52 lbs	AD63-1248C	43 lbs
12" x 60"	WR63-1260C	60 lbs	AD63-1260C	51 lbs
12" x 72"	WR63-1272C	68 lbs	AD63-1272C	59 lbs
14" x 24"	WR63-1424C	40 lbs	AD63-1424C	31 lbs
14" x 30"	WR63-1430C	44 lbs	AD63-1430C	35 lbs
14" x 36"	WR63-1436C	48 lbs	AD63-1436C	39 lbs
14" x 42"	WR63-1442C	56 lbs	AD63-1442C	47 lbs
14" x 48"	WR63-1448C	60 lbs	AD63-1448C	51 lbs
14" x 54"	WR63-1454C	64 lbs	AD63-1454C	55 lbs
14" x 60"	WR63-1460C	72 lbs	AD63-1460C	63 lbs
14" x 72"	WR63-1472C	84 lbs	AD63-1472C	75 lbs
18" x 24"	WR63-1824C	44 lbs	AD63-1824C	35 lbs
18" x 30"	WR63-1830C	48 lbs	AD63-1830C	39 lbs
18" x 36"	WR63-1836C	54 lbs	AD63-1836C	49 lbs
18" x 42"	WR63-1842C	58 lbs	AD63-1842C	53 lbs
18" x 48"	WR63-1848C	62 lbs	AD63-1848C	57 lbs
18" x 54"	WR63-1854C	74 lbs	AD63-1854C	69 lbs
18" x 60"	WR63-1860C	82 lbs	AD63-1860C	77 lbs
18" x 72"	WR63-1872C	94 lbs	AD63-1872C	89 lbs
21" x 24"	WR63-2124C	46 lbs	AD63-2124C	41 lbs
21" x 30"	WR63-2130C	50 lbs	AD63-2130C	45 lbs
21" x 36"	WR63-2136C	58 lbs	AD63-2136C	53 lbs
21" x 42"	WR63-2142C	62 lbs	AD63-2142C	57 lbs
21" x 48"	WR63-2148C	70 lbs	AD63-2148C	65 lbs
21" x 54"	WR63-2154C	78 lbs	AD63-2154C	73 lbs
21" x 60"	WR63-2160C	86 lbs	AD63-2160C	81 lbs
21" x 72"	WR63-2172C	110 lbs	AD63-2172C	105 lbs
24" x 24"	WR63-2424C	50 lbs	AD63-2424C	45 lbs
24" x 30"	WR63-2430C	58 lbs	AD63-2430C	53 lbs
24" x 36"	WR63-2436C	66 lbs	AD63-2436C	61 lbs
24" x 42"	WR63-2442C	74 lbs	AD63-2442C	69 lbs
24" x 48"	WR63-2448C	78 lbs	AD63-2448C	73 lbs
24" x 54"	WR63-2454C	86 lbs	AD63-2454C	81 lbs
24" x 60"	WR63-2460C	98 lbs	AD63-2460C	93 lbs
24" x 72"	WR63-2472C	118 lbs	AD63-2472C	113 lbs
30" x 36"	WR63-3036C	74 lbs	AD63-3036C	69 lbs
30" x 42"	WR63-3042C	86 lbs	AD63-3042C	81 lbs
30" x 48"	WR63-3048C	98 lbs	AD63-3048C	93 lbs
30" x 60"	WR63-3060C	122 lbs	AD63-3060C	117 lbs
30" x 72"	WR63-3072C	138 lbs	AD63-3072C	133 lbs
36" x 36"	WR63-3636C	86 lbs	AD63-3636C	81 lbs
36" x 48"	WR63-3648C	106 lbs	AD63-3648C	101 lbs
36" x 60"	WR63-3660C	130 lbs	AD63-3660C	125 lbs
36" x 72"	WR63-3672C	138 lbs	AD63-3672C	133 lbs

Shelving units include 4 posts and 4 shelves. Add-On units include 2 posts, 4 shelves and 8 S-Hooks.

74" CHROME WIRE SHELVING SYSTEMS

Starter Kits

Heavy-duty shelving unit allows up to 800 lb. shelf capacity. Starter kits come complete with 4 posts and 4 shelves. Additional shelves may be purchased separately. See chart on page 88. Mobilize starter shelving unit using optional mobile kit, WR-00 or WR-00H available on page 123.

Add-On Kits

Additional Add-On kit allows you to expand your Starter kit by sharing a set of posts. Configuration options include straight line, back to back and right angles (L-Shape). Add-On kits come complete with 2 posts, 4 shelves and 8 S-Hooks. Additional shelves may be purchased separately. See chart on page 88. Units with Add-On kit cannot be made mobile.



L Shape Unit

SHELF W" x L"	74"H WIRE SHELVING STARTER KIT		74"H WIRE SHELVING ADD-ON KIT	
	MODEL NO.	SHIP WGT	MODEL NO.	SHIP WGT
12" x 36"	WR74-1236C	44 lbs	AD74-1236C	38 lbs
12" x 42"	WR74-1242C	48 lbs	AD74-1242C	42 lbs
12" x 48"	WR74-1248C	52 lbs	AD74-1248C	46 lbs
12" x 60"	WR74-1260C	60 lbs	AD74-1260C	54 lbs
12" x 72"	WR74-1272C	68 lbs	AD74-1272C	62 lbs
14" x 24"	WR74-1424C	40 lbs	AD74-1424C	34 lbs
14" x 30"	WR74-1430C	44 lbs	AD74-1430C	38 lbs
14" x 36"	WR74-1436C	48 lbs	AD74-1436C	42 lbs
14" x 42"	WR74-1442C	56 lbs	AD74-1442C	50 lbs
14" x 48"	WR74-1448C	60 lbs	AD74-1448C	54 lbs
14" x 54"	WR74-1454C	64 lbs	AD74-1454C	58 lbs
14" x 60"	WR74-1460C	72 lbs	AD74-1460C	66 lbs
14" x 72"	WR74-1472C	84 lbs	AD74-1472C	78 lbs
18" x 24"	WR74-1824C	44 lbs	AD74-1824C	38 lbs
18" x 30"	WR74-1830C	48 lbs	AD74-1830C	42 lbs
18" x 36"	WR74-1836C	56 lbs	AD74-1836C	50 lbs
18" x 42"	WR74-1842C	60 lbs	AD74-1842C	54 lbs
18" x 48"	WR74-1848C	64 lbs	AD74-1848C	58 lbs
18" x 54"	WR74-1854C	76 lbs	AD74-1854C	70 lbs
18" x 60"	WR74-1860C	84 lbs	AD74-1860C	78 lbs
18" x 72"	WR74-1872C	96 lbs	AD74-1872C	90 lbs
21" x 24"	WR74-2124C	48 lbs	AD74-2124C	42 lbs
21" x 30"	WR74-2130C	52 lbs	AD74-2130C	46 lbs
21" x 36"	WR74-2136C	60 lbs	AD74-2136C	54 lbs
21" x 42"	WR74-2142C	64 lbs	AD74-2142C	58 lbs
21" x 48"	WR74-2148C	72 lbs	AD74-2148C	66 lbs
21" x 54"	WR74-2154C	80 lbs	AD74-2154C	74 lbs
21" x 60"	WR74-2160C	88 lbs	AD74-2160C	82 lbs
21" x 72"	WR74-2172C	112 lbs	AD74-2172C	106 lbs
24" x 24"	WR74-2424C	52 lbs	AD74-2424C	46 lbs
24" x 30"	WR74-2430C	60 lbs	AD74-2430C	54 lbs
24" x 36"	WR74-2436C	68 lbs	AD74-2436C	62 lbs
24" x 42"	WR74-2442C	76 lbs	AD74-2442C	70 lbs
24" x 48"	WR74-2448C	80 lbs	AD74-2448C	74 lbs
24" x 54"	WR74-2454C	88 lbs	AD74-2454C	82 lbs
24" x 60"	WR74-2460C	100 lbs	AD74-2460C	94 lbs
24" x 72"	WR74-2472C	120 lbs	AD74-2472C	114 lbs
30" x 36"	WR74-3036C	76 lbs	AD74-3036C	70 lbs
30" x 42"	WR74-3042C	88 lbs	AD74-3042C	82 lbs
30" x 48"	WR74-3048C	100 lbs	AD74-3048C	94 lbs
30" x 60"	WR74-3060C	124 lbs	AD74-3060C	118 lbs
30" x 72"	WR74-3072C	140 lbs	AD74-3072C	134 lbs
36" x 36"	WR74-3636C	88 lbs	AD74-3636C	82 lbs
36" x 48"	WR74-3648C	108 lbs	AD74-3648C	102 lbs
36" x 60"	WR74-3660C	132 lbs	AD74-3660C	126 lbs
36" x 72"	WR74-3672C	140 lbs	AD74-3672C	134 lbs

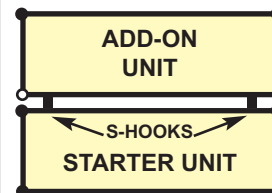
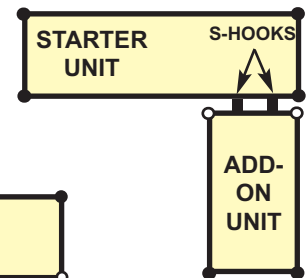
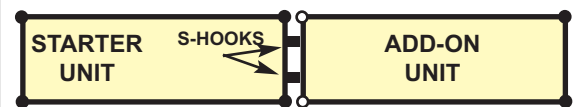

Dividers, Ledges and Inlay Mats are just some of the accessories available on pages 124-125

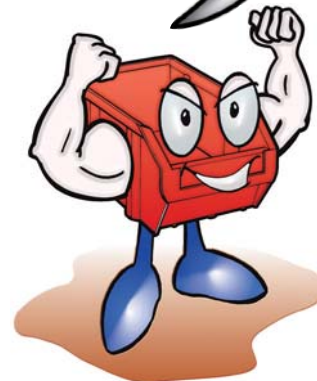

Fastest
Shipping
IN THE INDUSTRY

**LOWEST
PRICE
GUARANTEED!**

Shelving units include 4 posts and 4 shelves. Add-On units include 2 posts, 4 shelves and 8 S-Hooks.

86" CHROME WIRE SHELVING SYSTEMS

Starter Kits

Heavy-duty shelving unit allows up to 800 lb. shelf capacity. Starter kits come complete with 4 posts and 4 shelves. Additional shelves may be purchased separately. See chart on page 88. Mobilize starter shelving unit using optional mobile kit, WR-00 or WR-00H available on page 123.

Add-On Kits

Additional Add-On kit allows you to expand your Starter kit by sharing a set of posts. Configuration options include straight line, back to back and right angles (L-Shape). Add-On kits come complete with 2 posts, 4 shelves and 8 S-Hooks. Additional shelves may be purchased separately. See chart on page 88. Units with Add-On kit cannot be made mobile.

SHELF W" x L"	86"H WIRE SHELVING STARTER KIT		86"H WIRE SHELVING ADD-ON KIT	
	MODEL NO.	SHIP WGT	MODEL NO.	SHIP WGT
12" x 36"	WR86-1236C	48 lbs	AD86-1236C	40 lbs
12" x 42"	WR86-1242C	52 lbs	AD86-1242C	44 lbs
12" x 48"	WR86-1248C	56 lbs	AD86-1248C	48 lbs
12" x 60"	WR86-1260C	64 lbs	AD86-1260C	56 lbs
12" x 72"	WR86-1272C	72 lbs	AD86-1272C	64 lbs
14" x 24"	WR86-1424C	44 lbs	AD86-1424C	36 lbs
14" x 30"	WR86-1430C	48 lbs	AD86-1430C	40 lbs
14" x 36"	WR86-1436C	52 lbs	AD86-1436C	44 lbs
14" x 42"	WR86-1442C	60 lbs	AD86-1442C	52 lbs
14" x 48"	WR86-1448C	64 lbs	AD86-1448C	56 lbs
14" x 54"	WR86-1454C	68 lbs	AD86-1454C	60 lbs
14" x 60"	WR86-1460C	76 lbs	AD86-1460C	68 lbs
14" x 72"	WR86-1472C	88 lbs	AD86-1472C	80 lbs
18" x 24"	WR86-1824C	48 lbs	AD86-1824C	40 lbs
18" x 30"	WR86-1830C	52 lbs	AD86-1830C	44 lbs
18" x 36"	WR86-1836C	60 lbs	AD86-1836C	52 lbs
18" x 42"	WR86-1842C	64 lbs	AD86-1842C	56 lbs
18" x 48"	WR86-1848C	68 lbs	AD86-1848C	60 lbs
18" x 54"	WR86-1854C	80 lbs	AD86-1854C	72 lbs
18" x 60"	WR86-1860C	88 lbs	AD86-1860C	80 lbs
18" x 72"	WR86-1872C	100 lbs	AD86-1872C	92 lbs
21" x 24"	WR86-2124C	52 lbs	AD86-2124C	44 lbs
21" x 30"	WR86-2130C	56 lbs	AD86-2130C	48 lbs
21" x 36"	WR86-2136C	64 lbs	AD86-2136C	56 lbs
21" x 42"	WR86-2142C	68 lbs	AD86-2142C	60 lbs
21" x 48"	WR86-2148C	76 lbs	AD86-2148C	68 lbs
21" x 54"	WR86-2154C	84 lbs	AD86-2154C	76 lbs
21" x 60"	WR86-2160C	92 lbs	AD86-2160C	84 lbs
21" x 72"	WR86-2172C	116 lbs	AD86-2172C	108 lbs
24" x 24"	WR86-2424C	56 lbs	AD86-2424C	48 lbs
24" x 30"	WR86-2430C	64 lbs	AD86-2430C	56 lbs
24" x 36"	WR86-2436C	72 lbs	AD86-2436C	64 lbs
24" x 42"	WR86-2442C	80 lbs	AD86-2442C	72 lbs
24" x 48"	WR86-2448C	84 lbs	AD86-2448C	76 lbs
24" x 54"	WR86-2454C	92 lbs	AD86-2454C	84 lbs
24" x 60"	WR86-2460C	104 lbs	AD86-2460C	96 lbs
24" x 72"	WR86-2472C	124 lbs	AD86-2472C	116 lbs
30" x 36"	WR86-3036C	80 lbs	AD86-3036C	72 lbs
30" x 42"	WR86-3042C	92 lbs	AD86-3042C	84 lbs
30" x 48"	WR86-3048C	104 lbs	AD86-3048C	96 lbs
30" x 60"	WR86-3060C	128 lbs	AD86-3060C	120 lbs
30" x 72"	WR86-3072C	144 lbs	AD86-3072C	136 lbs
36" x 36"	WR86-3636C	92 lbs	AD86-3636C	84 lbs
36" x 48"	WR86-3648C	112 lbs	AD86-3648C	104 lbs
36" x 60"	WR86-3660C	136 lbs	AD86-3660C	128 lbs
36" x 72"	WR86-3672C	144 lbs	AD86-3672C	136 lbs

Shelving units include 4 posts and 4 shelves. Add-On units include 2 posts, 4 shelves and 8 S-Hooks.



Side to Side Unit

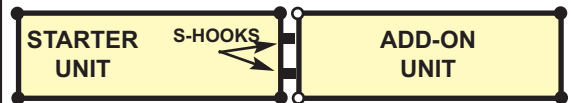

L Shape Unit

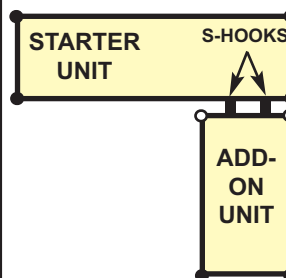

Back to Back Unit

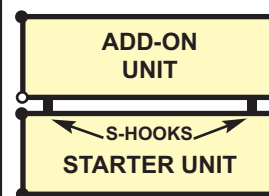

**LOWEST
PRICE
GUARANTEED!**

PROFORM WIRE SHELVING UNITS

Starter Kits

Heavy-duty shelving unit allows up to 800 lb. shelf capacity. Starter kits come complete with 4 posts and 4 shelves. Additional shelves may be purchased separately. See chart on page 88. Mobilize starter shelving unit using optional mobile kit, WR-00 or WR-00H available on page 123.



Add-On Kits

Additional Add-On kit allows you to expand your Starter kit by sharing a set of posts. Configuration options include straight line, back to back and right angles (L-Shape). Add-On kits come complete with 2 posts, 4 shelves and 8 S-Hooks. Additional shelves may be purchased separately. See chart on page 88. Units with Add-On kit cannot be made mobile.

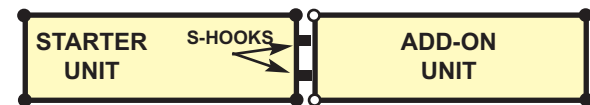
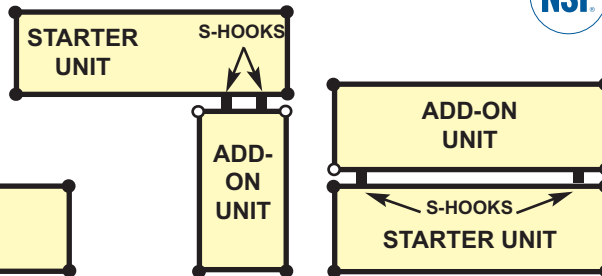

SHELF W" x L"	PROFORM STARTER KITS		PROFORM ADD-ON KITS		PROFORM STARTER KITS		PROFORM ADD-ON KITS		
	MODEL NO.	SHIP WGT	MODEL NO.	SHIP WGT	MODEL NO.	SHIP WGT	MODEL NO.	SHIP WGT	
54"H Proform Wire Shelving				74"H Proform Wire Shelving					
14" x 36"	WR54-1436P	44	AD54-1436P	40	WR74-1436P	48	AD74-1436P	42	
14" x 48"	WR54-1448P	56	AD54-1448P	52	WR74-1448P	60	AD74-1448P	54	
14" x 60"	WR54-1460P	68	AD54-1460P	64	WR74-1460P	72	AD74-1460P	66	
14" x 72"	WR54-1472P	80	AD54-1472P	76	WR74-1472P	84	AD74-1472P	78	
18" x 30"	WR54-1830P	44	AD54-1830P	40	WR74-1830P	48	AD74-1830P	42	
18" x 36"	WR54-1836P	52	AD54-1836P	48	WR74-1836P	56	AD74-1836P	50	
18" x 42"	WR54-1842P	56	AD54-1842P	52	WR74-1842P	60	AD74-1842P	54	
18" x 48"	WR54-1848P	60	AD54-1848P	56	WR74-1848P	64	AD74-1848P	58	
18" x 54"	WR54-1854P	72	AD54-1854P	64	WR74-1854P	76	AD74-1854P	70	
18" x 60"	WR54-1860P	80	AD54-1860P	76	WR74-1860P	84	AD74-1860P	78	
18" x 72"	WR54-1872P	92	AD54-1872P	36	WR74-1872P	96	AD74-1872P	90	
24" x 30"	WR54-2430P	56	AD54-2430P	52	WR74-2430P	60	AD74-2430P	54	
24" x 36"	WR54-2436P	64	AD54-2436P	60	WR74-2436P	68	AD74-2436P	62	
24" x 42"	WR54-2442P	72	AD54-2442P	68	WR74-2442P	76	AD74-2442P	70	
24" x 48"	WR54-2448P	76	AD54-2448P	72	WR74-2448P	80	AD74-2448P	74	
24" x 54"	WR54-2454P	84	AD54-2454P	80	WR74-2454P	88	AD74-2454P	82	
24" x 60"	WR54-2460P	96	AD54-2460P	92	WR74-2460P	100	AD74-2460P	94	
24" x 72"	WR54-2472P	116	AD54-2472P	114	WR74-2472P	120	AD74-2472P	114	
63"H Proform Wire Shelving				86"H Proform Wire Shelving					
14" x 36"	WR63-1436P	48	AD63-1436P	41	WR86-1436P	52	AD86-1436P	44	
14" x 48"	WR63-1448P	60	AD63-1448P	53	WR86-1448P	64	AD86-1448P	56	
14" x 60"	WR63-1460P	72	AD63-1460P	65	WR86-1460P	76	AD86-1460P	68	
14" x 72"	WR63-1472P	84	AD63-1472P	77	WR86-1472P	88	AD86-1472P	80	
18" x 30"	WR63-1830P	48	AD63-1830P	41	WR86-1830P	52	AD86-1830P	44	
18" x 36"	WR63-1836P	54	AD63-1836P	49	WR86-1836P	60	AD86-1836P	52	
18" x 42"	WR63-1842P	58	AD63-1842P	53	WR86-1842P	64	AD86-1842P	56	
18" x 48"	WR63-1848P	62	AD63-1848P	57	WR86-1848P	68	AD86-1848P	60	
18" x 54"	WR63-1854P	74	AD63-1854P	69	WR86-1854P	80	AD86-1854P	72	
18" x 60"	WR63-1860P	82	AD63-1860P	77	WR86-1860P	88	AD86-1860P	80	
18" x 72"	WR63-1872P	94	AD63-1872P	89	WR86-1872P	100	AD86-1872P	92	
24" x 30"	WR63-2430P	58	AD63-2430P	53	WR86-2430P	64	AD86-2430P	56	
24" x 36"	WR63-2436P	66	AD63-2436P	61	WR86-2436P	72	AD86-2436P	64	
24" x 42"	WR63-2442P	74	AD63-2442P	69	WR86-2442P	80	AD86-2442P	72	
24" x 48"	WR63-2448P	78	AD63-2448P	73	WR86-2448P	84	AD86-2448P	76	
24" x 54"	WR63-2454P	86	AD63-2454P	81	WR86-2454P	92	AD86-2454P	84	
24" x 60"	WR63-2460P	98	AD63-2460P	93	WR86-2460P	104	AD86-2460P	96	
24" x 72"	WR63-2472P	118	AD63-2472P	113	WR86-2472P	124	AD86-2472P	116	

Starter Kits include 4 posts and 4 shelves. Add-On Kits include 2 posts, 4 shelves and 8 S-Hooks.

STAINLESS STEEL WIRE SHELVING UNITS

Starter Kits

Heavy-duty shelving unit allows up to 800 lb. shelf capacity. Starter kits come complete with 4 posts and 4 shelves. Additional shelves may be purchased separately. See chart on page 88. Mobilize starter shelving unit using optional mobile kit, WR-00 or WR-00H available on page 123.

Add-On Kits

Additional Add-On kit allows you to expand your Starter kit by sharing a set of posts. Configuration options include straight line, back to back and right angles (L-Shape). Add-On kits come complete with 2 posts, 4 shelves and 8 S-Hooks. Additional shelves may be purchased separately. See chart on page 88. Units with Add-On kit cannot be made mobile.

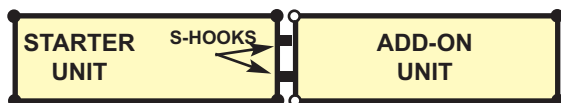

L Shape Unit

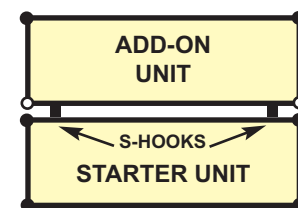
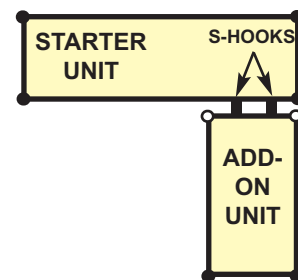

SHELF W" x L"	STAINLESS STEEL STARTER KITS		STAINLESS STEEL ADD-ON KITS	
	MODEL NO.	SHIP WGT	MODEL NO.	SHIP WGT
54"H Stainless Steel Wire Shelving				
18" x 36"	WR54-1836S	52	AD54-1836S	48
18" x 48"	WR54-1848S	60	AD54-1848S	56
18" x 60"	WR54-1860S	80	AD54-1860S	76
18" x 72"	WR54-1872S	92	AD54-1872S	36
24" x 36"	WR54-2436S	64	AD54-2436S	60
24" x 48"	WR54-2448S	76	AD54-2448S	72
24" x 60"	WR54-2460S	96	AD54-2460S	92
24" x 72"	WR54-2472S	116	AD54-2472S	114
63"H Stainless Steel Wire Shelving				
18" x 36"	WR63-1836S	54	AD63-1836S	49
18" x 48"	WR63-1848S	62	AD63-1848S	57
18" x 60"	WR63-1860S	82	AD63-1860S	77
18" x 72"	WR63-1872S	94	AD63-1872S	89
24" x 36"	WR63-2436S	66	AD63-2436S	61
24" x 48"	WR63-2448S	78	AD63-2448S	73
24" x 60"	WR63-2460S	98	AD63-2460S	93
24" x 72"	WR63-2472S	118	AD63-2472S	113
74"H Stainless Steel Wire Shelving				
18" x 36"	WR74-1836S	56	AD74-1836S	50
18" x 48"	WR74-1848S	64	AD74-1848S	58
18" x 60"	WR74-1860S	84	AD74-1860S	78
18" x 72"	WR74-1872S	96	AD74-1872S	90
24" x 36"	WR74-2436S	68	AD74-2436S	62
24" x 48"	WR74-2448S	80	AD74-2448S	74
24" x 60"	WR74-2460S	100	AD74-2460S	94
24" x 72"	WR74-2472S	120	AD74-2472S	114
86"H Stainless Steel Wire Shelving				
18" x 36"	WR86-1836S	60	AD86-1836S	52
18" x 48"	WR86-1848S	68	AD86-1848S	60
18" x 60"	WR86-1860S	88	AD86-1860S	80
18" x 72"	WR86-1872S	100	AD86-1872S	92
24" x 36"	WR86-2436S	72	AD86-2436S	64
24" x 48"	WR86-2448S	84	AD86-2448S	76
24" x 60"	WR86-2460S	104	AD86-2460S	96
24" x 72"	WR86-2472S	124	AD86-2472S	116

Starter Kits include 4 posts and 4 shelves. Add-On Kits include 2 posts, 4 shelves and 8 S-Hooks.



SOLID SHELF UNITS



WR74-1848SG + AD74-1836SG

Galvanized or 304 Stainless Steel



LOWEST PRICE GUARANTEED!

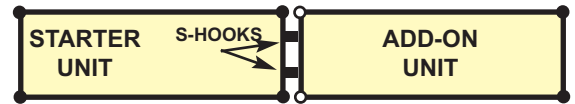
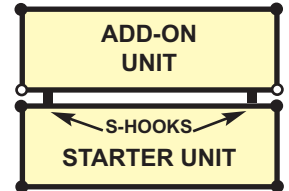
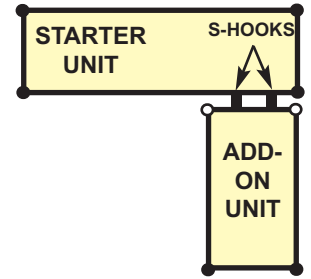

Shelf Clamp
Model No.: QSMC

Shelf Clamp eliminates 2 post per shelving section. Two QSMC clamps are required per shelf. Finish: Aluminum

Solid Shelf Starter and Add-On Kits

Solid shelves are a solution where dirt, dust and spills are a potential issue. The solid flat surface allows for storage from small to large items and the marine edge perimeter prevents spillage. The double hemmed 18 gauge galvanized steel gives the solid shelf excellent strength characteristics. All solid shelf units consist of 4 shelves and 4 posts. Add-on units consist of 4 shelves, 2 posts and 8 shelf clamps. Additional shelves may be purchased separately, see chart on page 89. Mobilize starter shelving unit using optional mobile kit, WR-00 or WR-00H available on page 123. Units with Add-On kit cannot be made mobile.

SHELF W" x L"	STARTER KIT			ADD-ON KIT		
	SHIP WGT	GALVANIZED STEEL STARTER KIT MODEL NO.	STAINLESS STEEL STARTER KIT MODEL NO.	SHIP WGT	GALVANIZED STEEL ADD-ON MODEL NO.	STAINLESS STEEL ADD-ON MODEL NO.
63"H Starter Kit				63"H Add-On Kit		
18" x 36"	78 lbs	WR63-1836SG	WRS4-63-1836SS	71 lbs	AD63-1836SG	WRSAD4-63-1836SS
18" x 48"	94 lbs	WR63-1848SG	WRS4-63-1848SS	87 lbs	AD63-1848SG	WRSAD4-63-1848SS
18" x 60"	110 lbs	WR63-1860SG	WRS4-63-1860SS	103 lbs	AD63-1860SG	WRSAD4-63-1860SS
24" x 36"	90 lbs	WR63-2436SG	WRS4-63-2436SS	83 lbs	AD63-2436SG	WRSAD4-63-2436SS
24" x 48"	110 lbs	WR63-2448SG	WRS4-63-2448SS	103 lbs	AD63-2448SG	WRSAD4-63-2448SS
24" x 60"	138 lbs	WR63-2460SG	WRS4-63-2460SS	131 lbs	AD63-2460SG	WRSAD4-63-2460SS
74"H Starter Kit				74"H Add-On Kit		
18" x 36"	80 lbs	WR74-1836SG	WRS4-74-1836SS	72 lbs	AD74-1836SG	WRSAD4-74-1836SS
18" x 48"	96 lbs	WR74-1848SG	WRS4-74-1848SS	88 lbs	AD74-1848SG	WRSAD4-74-1848SS
18" x 60"	112 lbs	WR74-1860SG	WRS4-74-1860SS	104 lbs	AD74-1860SG	WRSAD4-74-1860SS
24" x 36"	90 lbs	WR74-2436SG	WRS4-74-2436SS	82 lbs	AD74-2436SG	WRSAD4-74-2436SS
24" x 48"	110 lbs	WR74-2448SG	WRS4-74-2448SS	102 lbs	AD74-2448SG	WRSAD4-74-2448SS
24" x 60"	138 lbs	WR74-2460SG	WRS4-74-2460SS	130 lbs	AD74-2460SG	WRSAD4-74-2460SS
86"H Starter Kit				86"H Add-On Kit		
18" x 36"	84 lbs	WR86-1836SG	WRS4-86-1836SS	74 lbs	AD86-1836SG	WRSAD4-86-1836SS
18" x 48"	100 lbs	WR86-1848SG	WRS4-86-1848SS	90 lbs	AD86-1848SG	WRSAD4-86-1848SS
18" x 60"	106 lbs	WR86-1860SG	WRS4-86-1860SS	96 lbs	AD86-1860SG	WRSAD4-86-1860SS
24" x 36"	96 lbs	WR86-2436SG	WRS4-86-2436SS	86 lbs	AD86-2436SG	WRSAD4-86-2436SS
24" x 48"	116 lbs	WR86-2448SG	WRS4-86-2448SS	106 lbs	AD86-2448SG	WRSAD4-86-2448SS
24" x 60"	144 lbs	WR86-2460SG	WRS4-86-2460SS	134 lbs	AD86-2460SG	WRSAD4-86-2460SS

Starter Kits include 4 posts and 4 shelves.

Add-On Kits include 2 posts, 4 shelves and 8 shelf clamps.

SLANTED SHELF WIRE SHELVING UNITS

Stationary and Mobile Slanted Shelf Carts

Stationary and Mobile Slanted Shelf units create a unique combination of modular components to enhance supply distribution applications. The sloped shelves allow for high visibility, productive rotations & gravity feed. Ideal for Par Level Systems.

(Note: Build a system with your bin requirements or consult a product specialist for appropriate components)

Each stationary unit consists of:

- 4 - 63" posts
- 2 - flat wire shelves
- 3 - slanted wire shelves

Each mobile unit consists of:

- 4 - 63" posts
- 2 - flat wire shelves
- 3 - slanted wire shelves
- 4 - 5" swivel poly stem casters, 2 with brakes
- 4 - donut bumpers



MWRS-5-92060

SLANTED SHELVING UNITS - 63"H					
		STATIONARY		MOBILE	
SHELF DIMENSIONS W" x L"	NO. OF SHELVES	MODEL NO.	SHIP WGT	MODEL NO.	SHIP WGT
18" x 36"	5	1836SL6C	54 lbs	M1836SL6C	62 lbs
18" x 48"	5	1848SL6C	65 lbs	M1848SL6C	73 lbs
24" x 36"	5	2436SL6C	78 lbs	M2436SL6C	86 lbs
24" x 48"	5	2448SL6C	90 lbs	M2448SL6C	98 lbs

COMPLETE PACKAGES with bins!

NO. OF BINS	BIN DIMENSIONS L" x W" x H"	NO. OF SHELVES	STATIONARY		MOBILE	
			MODEL NO.	SHIP WGT	MODEL NO.	SHIP WGT
18"W x 36"L x 63"H Slanted Wire Shelving With Dividable Grid Containers 2 Horizontal Shelves and 3 Slanted Shelves						
12 DG92035	16-1/2" x 10-7/8" x 3-1/2"	5	WRS-5-92035	128 lbs	MWRS-5-92035	136 lbs
12 DG92060	16-1/2" x 10-7/8" x 6"	5	WRS-5-92060	135 lbs	MWRS-5-92060	143 lbs
12 DG92080	16-1/2" x 10-7/8" x 8"	5	WRS-5-92080	145 lbs	MWRS-5-92080	153 lbs
18"W x 36"L x 74"H Slanted Wire Shelving With Economy Shelf Bins 2 Horizontal Shelves and 5 Slanted Shelves						
48 QSB103	17-7/8" x 4-1/8" x 4"	7	WRS-7-103	153 lbs	MWRS-7-103	161 lbs
30 QSB104	17-7/8" x 6-5/8" x 4"	7	WRS-7-104	146 lbs	MWRS-7-104	154 lbs
24 QSB108	17-7/8" x 8-3/8" x 4"	7	WRS-7-108	143 lbs	MWRS-7-108	151 lbs
18 QSB110	17-7/8" x 11-1/8" x 4"	7	WRS-7-110	144 lbs	MWRS-7-110	152 lbs
18"W x 36"L x 74"H Slanted Wire Shelving With Euro Drawers 2 Horizontal Shelves and 5 Slanted Shelves						
54 QED604	17-5/8" x 3-3/4" x 4-5/8"	7	WRS-7-604	182 lbs	MWRS-7-604	190 lbs
36 QED602	17-5/8" x 5-9/16" x 4-5/8"	7	WRS-7-602	169 lbs	MWRS-7-602	177 lbs
24 QED606	17-5/8" x 8-3/8" x 4-5/8"	7	WRS-7-606	159 lbs	MWRS-7-606	167 lbs

Dividable Grid Containers available in Blue, Gray, Red and Clear. Economy Shelf Bins available in Blue, Green, Ivory, Red, Yellow, Black and Clear. Euro Drawers available in Blue, Gray, Red and Yellow.



MWRS-7-104

Work Station Cart - the ideal work-in-process cart!

The sloped shelves allow for high visibility, productive rotations & gravity feed. Cart finish: Chrome

Each unit consists of:

- 2 - 34" posts
- 2 - 27" posts
- 1 - flat wire shelf
- 1 - slanted wire shelf
- 4 - 5" swivel poly stem casters, 2 with brakes
- 4 - donut bumpers

**LOWEST
PRICE
GUARANTEED!**

WORK STATION CARTS - 40"H			
MOBILE MODEL NO.	SHELF DIMENSIONS W" x L"	NO. OF SHELVES	SHIP WGT
M1836SL34C	18" x 36"	2	35 lbs
M1848SL34C	18" x 48"	2	40 lbs
M2436SL34C	24" x 36"	2	42 lbs
M2448SL34C	24" x 48"	2	46 lbs



M1836SL34C



M1836SL34C
Shown with Bins
(Bins sold separately)

SHELVES, FRAMES & BASKETS

Dunnage Shelf

Utilized in extreme load applications. Shelf is constructed of square tubing and a removable top wire grid. 1,500 lb. capacity. Finish: Endurance

ENDURANCE MODEL NO.	DIMENSIONS W" x L"	SHIP WGT
1836DS	18" x 36"	21 lbs
1848DS	18" x 48"	28 lbs
1860DS	18" x 60"	34 lbs
2436DS	24" x 36"	24 lbs
2448DS	24" x 48"	30 lbs
2460DS	24" x 60"	37 lbs



1836DS

3 Sided Frame

Constructed of 1" square tubing, frame is designed for added structure to the perimeter of a dunnage or shelving unit. Finish: Endurance

ENDURANCE MODEL NO.	DIMENSIONS W" x L"	SHIP WGT
1836F	18" x 36"	7 lbs
1848F	18" x 48"	8 lbs
1860F	18" x 60"	9 lbs
2436F	24" x 36"	8 lbs
2448F	24" x 48"	9 lbs
2460F	24" x 60"	10 lbs



1836F

3 Sided Frame

Designed to add structure to various applications and retain products. Finish: 304 Stainless Steel

STAINLESS MODEL NO.	DIMENSIONS W" x L"	SHIP WGT
2436FS	24" x 36"	8 lbs
2448FS	24" x 48"	9 lbs
2460FS	24" x 60"	10 lbs



2436FS

Slanted Shelf

For high visibility, gravity feed and stock rotation. Shelves are adjustable on 1" increments and have a 400 lb. load capacity. Shelves can be used on stationary and mobile units for greater efficiency. Finish: Chrome

CHROME MODEL NO.	DIMENSIONS W" x L"	SHIP WGT
1836SL	18" x 36"	10 lbs
1848SL	18" x 48"	12 lbs
2436SL	24" x 36"	13 lbs
2448SL	24" x 48"	15 lbs



1836SL

Modular Stacking Basket

An effective way to customize standard stationary or mobile units for inventory or supply applications. Ensures high visibility and allows super adjustability. Optional adjustable dividers allow for separation of product. 110 lb. capacity. Finish: Chrome

MODEL NO.	BASKET DIMENSIONS W" x L" x H"	SHIP WGT	DIVIDER MODEL NO.	SHIP WGT
1436BC	14" x 36" x 9"	10 lbs	149DC	1 lb
1448BC	14" x 48" x 9"	13 lbs	149DC	1 lb
2036BC	20" x 36" x 9"	12 lbs	209DC	2 lbs
2048BC	20" x 48" x 9"	15 lbs	209DC	2 lbs
203612BC	20" x 36" x 12"	14 lbs	2012DC	2 lbs
204812BC	20" x 48" x 12"	16 lbs	2012DC	2 lbs



1436BC
Shown with Dividers

DUNNAGE & PLATFORM RACKS



183614DE

Modular Dunnage Unit

Ideal for extreme load capacities (1,500 lb.). Includes tubular 1" square frame super structure and removable wire top mat. Finish: Endurance

Each unit consists of:

- 4 - 14" posts
- 1 - 3-sided frame
- 1 - dunnage shelf

ENDURANCE MODEL NO.	DIMENSIONS W" x L" x H"	SHIP WGT
183614DE	18" x 36" x 14"	28 lbs
184814DE	18" x 48" x 14"	36 lbs
186014DE	18" x 60" x 14"	43 lbs
243614DE	24" x 36" x 14"	32 lbs
244814DE	24" x 48" x 14"	39 lbs
246014DE	24" x 60" x 14"	47 lbs



M18366DE

Mobile Dunnage Platform

With 5" Poly non-marking stem casters add flexibility. Units can be used for moving case goods and other heavy items for cleaning, warehouse and stock room applications. Finish: Endurance

Each unit consists of:

- 4 - 6" posts
- 1 - 3-sided frame
- 1 - dunnage shelf
- 4 - 5" swivel poly stem casters, 2 with brakes
- 4 - donut bumpers

ENDURANCE MODEL NO.	DIMENSIONS W" x L" x H"	SHIP WGT
M18366DE	18" x 36" x 12"	36 lbs
M18486DE	18" x 48" x 12"	44 lbs
M18606DE	18" x 60" x 12"	51 lbs
M24366DE	24" x 36" x 12"	40 lbs
M24486DE	24" x 48" x 12"	47 lbs
M24606DE	24" x 60" x 12"	55 lbs



183654DE

Tank & Beverage Container (1 & 2 Tier)

Represents a cost effective way to keep containers off the floor for cleanliness. This unit is an effective way to tidy up and increase available storage capacity. Used frequently in cafeterias and warehouse applications. Finish: Endurance

Each 1 Tier unit consists of:

- 4 - 34" posts
- 1 - 3-sided frame
- 1 - dunnage shelf

Each 2 Tier unit consists of:

- 4 - 54" posts
- 2 - 3-sided frames
- 2 - dunnage shelves

ENDURANCE MODEL NO.	DIMENSIONS W" x L" x H"	SHIP WGT
1 Tier		
183634DE	18" x 36" x 34"	40 lbs
184834DE	18" x 48" x 34"	48 lbs
186034DE	18" x 60" x 34"	55 lbs
243634DE	24" x 36" x 34"	44 lbs
244834DE	24" x 48" x 34"	51 lbs
246034DE	24" x 60" x 34"	59 lbs
2 Tier		
183654DE	18" x 36" x 54"	68 lbs
184854DE	18" x 48" x 54"	84 lbs
186054DE	18" x 60" x 54"	98 lbs
243654DE	24" x 36" x 54"	76 lbs
244854DE	24" x 48" x 54"	90 lbs
246054DE	24" x 60" x 54"	106 lbs



Shelf Platform Rack

Represents an ergonomic solution for keeping case goods off the floor. Platforms are often used at workstations and prep storage areas. Finish: Chrome/Endurance



183614PC

Each unit consists of:

- 4 - 14" posts
- 1 - shelf

DIMENSIONS W" x L" x H"	SHIP WGT	CHROME MODEL NO.	ENDURANCE MODEL NO.
18" x 36" x 14"	14 lbs	183614PC	183614PE
18" x 48" x 14"	18 lbs	184814PC	184814PE
18" x 60" x 14"	21 lbs	186014PC	186014PE
24" x 36" x 14"	17 lbs	243614PC	243614PE
24" x 48" x 14"	20 lbs	244814PC	244814PE
24" x 60" x 14"	25 lbs	246014PC	246014PE



482212DPP

Polymer Dunnage Platform

Ergonomically designed, Polymer Dunnage Platform is ideal to keep items off the ground. This lightweight, structural foam, high density polyethylene platform holds up to 4,000 lbs. and can withstand temperatures from -20° to 212°F. This one piece constructed unit will not rust or corrode, is impervious to mold and mildew, and can be steam cleaned and is super sanitary. 10" clearance allows for fast and easy cleaning. NSF Approved.

Material: High Density Polyethylene

MODEL NO.	DIMENSIONS W" x L" x H"	SHIP WGT
482212DPP	22" x 48" x 12"	16 lbs

WIRE STACKING BASKETS



Modular Stacking Baskets

Offer a variety of storage, display and mobile supply applications. Dividers can be used to separate product. Accessible front and a wide selection of sizes allow for all types of product to be used from storage to display. (Dividers sold separately) Finish: Chrome



1436BC
Shown with Dividers
and Clear Label Holder
(Sold separately)

Clear Label Holders

A user friendly method for identifying product. Affixes directly to the front on any basket. Available in three lengths. (Sold separately)

MODEL NO.	DESCRIPTION	SHIP WGT
Clear Label Holders		
BLH3C	3" Clear Label Holder	1 lb
BLH14C	14" Clear Label Holder	1 lb
BLH32C	32" Clear Label Holder	1 lb

MODEL NO.	BASKET DIMENSIONS W" x L" x H"	SHIP WGT	DIVIDER MODEL NO.	SHIP WGT
1436BC	14" x 36" x 9"	10 lbs	149DC	1 lb
1448BC	14" x 48" x 9"	13 lbs	149DC	1 lb
2036BC	20" x 36" x 9"	12 lbs	209DC	2 lbs
2048BC	20" x 48" x 9"	15 lbs	209DC	2 lbs
203612BC	20" x 36" x 12"	14 lbs	2012DC	2 lbs
204812BC	20" x 48" x 12"	16 lbs	2012DC	2 lbs

Order this exact unit
WR5-36MSBA

Unit consists of:
2 - baskets 1436BC
2 - dividers 149DC
3 - baskets 203612BC
3 - dividers 2012DC



**LOWEST
PRICE
GUARANTEED!**

Order this exact unit
WR5-36MSBA-MOB

Unit consists of:
2 - baskets 1436BC
2 - dividers 149DC
3 - baskets 203612BC
3 - dividers 2012DC
1 - dolly M2036BD

Dolly Base

Includes 4 - 5" swivel casters which offers versatility to any unit.

MODEL NO.	DIMENSIONS W" x L"	SHIP WGT
M2036BD	20" x 36"	32 lbs
M2048BD	20" x 48"	34 lbs

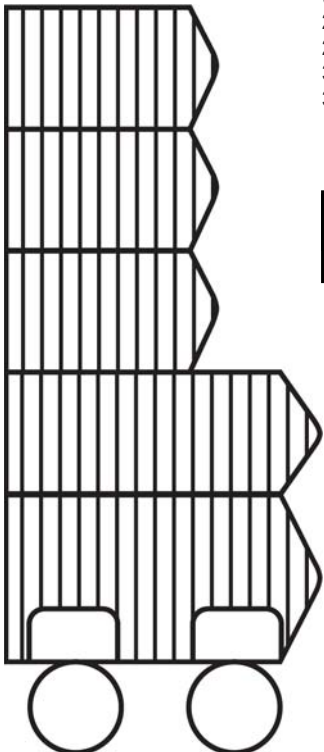

Build & stack any combination of baskets for your requirements. Larger baskets must be positioned on the lowest point.

WIRE BASKET UNITS



1836BC6C
(Dividers sold separately)

Quantum Stationary Wire Basket Units

Basket units allow high visibility and air circulation. The basket acts as a dispensing and storage module which can be added to 18", 21" and 24" deep shelving units. The collar hook allows the basket to be removed or adjusted to accommodate various product mix and sizes. Baskets are adjustable on 1" increments. 110 lb. load capacity per basket. Adjustable baskets used in combination with shelves are an excellent method to store all types of products. Units can be stationary or mobile. Casters add flexibility and convert stationary units into transport systems. Ideal for exchange charts and par level storage. **(Note: Dividers sold separately)** Finish: Chrome

Each stationary unit consists of:

- 4 - 63"H posts
- 3 - adjustable baskets including collar hooks
- 2 - wire shelves



STATIONARY MODEL NO.	DIMENSIONS W" x L" x H"	NO. OF SHELVES	NO. OF BASKETS	SHIP WGT
1836BC6C	18" x 36" x 63"	2	3	70 lbs
1848BC6C	18" x 48" x 63"	2	3	82 lbs
2436BC6C	24" x 36" x 63"	2	3	85 lbs
2448BC6C	24" x 48" x 63"	2	3	100 lbs



SCH1-5

Collar Hooks

Hooks onto basket corner allowing basket to securely hang.

MODEL NO.	DESCRIPTION	SHIP WGT
SCH1-5	Four 1-1/2" Collar Hooks	1 lb
SCH1	Four 1/2" Collar Hooks	1 lb

Quantum Mobile Wire Basket Units

Each mobile unit consists of:

- 4 - 63"H posts
- 3 - adjustable baskets including collar hooks
- 2 - wire shelves
- 4 - donut bumpers
- 4 - swivel 5" x 1-1/4" polyurethane casters, 2 with brakes



MOBILE MODEL NO.	DIMENSIONS W" x L" x H"	NO. OF SHELVES	NO. OF BASKETS	SHIP WGT
M1836BC6C	18" x 36" x 69"	2	3	78 lbs
M1848BC6C	18" x 48" x 69"	2	3	90 lbs
M2436BC6C	24" x 36" x 69"	2	3	93 lbs
M2448BC6C	24" x 48" x 69"	2	3	108 lbs



M1836BC6C
(Dividers sold separately)

**Basket adjust on 1" increments
3 positions for maximizing efficiency.**



Angle Down
Flows parts to front
Provides maximum accessibility



Flat
Provides maximum space efficiency



Angled Up
Provides maximum bin capacity

NEW! PARTITION LEVEL WALL SYSTEMS

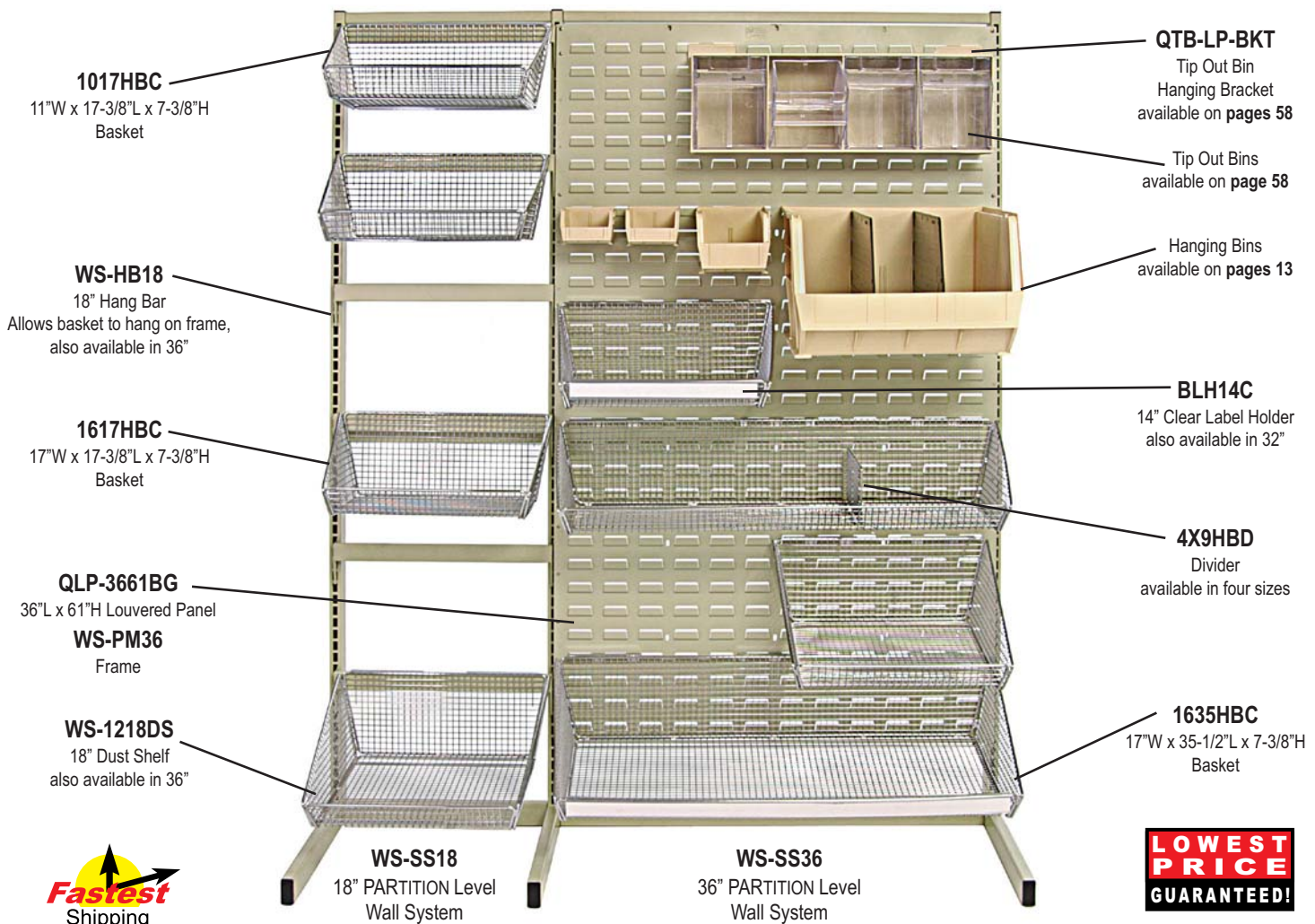

LOWEST PRICE GUARANTEED!

Starter Units

Starter units come complete with two uprights and three tie-bars.



WS-SS18



WS-SS36



WS-DS36
Shown with Baskets
(Sold separately)

Add-On Units

Add-On units allow you to expand your Starter unit by sharing an upright. Add-On unit includes one common upright and three tie-bars.

Customize your own unit!

For Units using Hang Bars:

1. Determine total space you want to fill from left to right
2. Select a Starter Unit (either 18", 36" or 48" wide)
3. Fill remaining space by utilizing Add-On Units
4. Determine how many basket levels you want to have per unit, which will correspond to the total number of hang bars needed
5. Decide if your system requires dust shelves, and if so, select appropriate size of shelf
6. Dividers and label holders are available for all basket sizes

For Units using Louvered Panels:

1. Determine total space you want to fill from left to right
2. Select a Starter Unit (either 18", 36" or 48" wide)
3. Fill remaining space by utilizing Add-On Units
4. Each unit (both Starter or Add-On) will fit a corresponding 18", 36" or 48" louvered panel (note: louvered panel requires one panel frame)
5. Louvered panel will accommodate:
 - Hanging Baskets - available on page 102
 - Clear Tip Out Bins - available on page 58 (note: one hanging bracket pair QTB-LP-BKT is needed per Tip Out Bin)
 - Plastic Bins - available on pages 13 (see chart on the bottom of page 15 to determine quantity of bins that fit on panel)

		ACCESSORIES							
STARTER UNIT		ADD-ON		HANG BAR	12" DUST SHELF	18" DUST SHELF	LOUVERED PANEL	PANEL FRAME	
L"	MODEL NO.	SHIP WGT	MODEL NO.	SHIP WGT	MODEL NO.	MODEL NO.	MODEL NO.	MODEL NO.	
Single Side Unit									
18"	WS-SS18	31 lbs	WS-SS18AD	19 lbs	WS-HB18	WS-1218DS	WS-1818DS	QLP-1861BG	WS-PM36
36"	WS-SS36	37 lbs	WS-SS36AD	25 lbs	WS-HB36	WS-1236DS	WS-1836DS	QLP-3661BG	WS-PM36
48"	WS-SS48	42 lbs	WS-SS48AD	30 lbs	-	-	-	QLP-4861BG	WS-PM48
Double Side Unit									
18"	WS-DS18	34 lbs	WS-DS18AD	21 lbs	WS-HB18	WS-1218DS	WS-1818DS	QLP-1861BG	WS-PM36
36"	WS-DS36	40 lbs	WS-DS36AD	27 lbs	WS-HB36	WS-1236DS	WS-1836DS	QLP-3661BG	WS-PM36
48"	WS-DS48	45 lbs	WS-DS48AD	32 lbs	-	-	-	QLP-4861BG	WS-PM48

NEW! PARTITION HANGING BASKETS & SYSTEMS



COMPLETE PACKAGES with Hanging Baskets!

NO. OF BASKETS	BASKET MODEL NO.	HANG BAR PACKAGES		LOUVERED PANEL PACKAGES	
		MODEL NO.	SHIP WGT	MODEL NO.	SHIP WGT
18" STAND -- Complete with Baskets					
6	1017HBC	WS-SS18-6BC1	79 lbs	WS-SS18-Q6BC1	82 lbs
3	1017HBC	WS-SS18-6BC2	82 lbs	WS-SS18-Q6BC2	85 lbs
3	1617HBC				
6	1617HBC	WS-SS18-6BC3	85 lbs	WS-SS18-Q6BC3	88 lbs
36" STAND -- Complete with Baskets					
12	1017HBC	WS-SS36-12BC1	121 lbs	WS-SS36-Q12BC1	134 lbs
6	1017HBC	WS-SS36-12BC2	127 lbs	WS-SS36-Q12BC2	143 lbs
6	1617HBC				
12	1617HBC	WS-SS36-12BC3	133 lbs	WS-SS36-Q12BC3	149 lbs
6	1035HBC	WS-SS36-6BC1	115 lbs	WS-SS36-Q6BC1	131 lbs
3	1035HBC	WS-SS36-6BC2	121 lbs	WS-SS36-Q6BC2	137 lbs
3	1635HBC				
6	1635HBC	WS-SS36-6BC3	127 lbs	WS-SS36-Q6BC3	143 lbs

PARTITION Hanging Baskets

PARTITION Hanging Baskets are uniquely designed for high visibility and easy access while maximizing your wall storage area. The wire construction minimizes dirt accumulation and allows air circulation. Baskets have a dividable grid pattern to partition product while letting you know when to reorder product and restock items. The patented baskets' nesting feature offers low freight cost and minimizes storage space when not in use. Available in 11" and 17" widths, and in 17-3/8" and 35-1/2" lengths. Finish: Chrome

MODEL NO.	OUTSIDE DIMENSIONS W" x L" x H"	INSIDE DIMENSIONS W" x L" x H"
Hanging Baskets		
1017HBC	11" x 17-3/8" x 7-3/8"	9-1/2" x 14-1/4" x 7-1/8"
1035HBC	11" x 35-1/2" x 7-3/8"	9-1/2" x 32-1/4" x 7-1/8"
1617HBC	17" x 17-3/8" x 7-3/8"	15" x 14-1/4" x 7-1/8"
1635HBC	17" x 35-1/2" x 7-3/8"	15" x 32-1/4" x 7-1/8"

PATENT PENDING

ACCESSORIES

Hang Bars

MODEL NO.	DESCRIPTION	SHIP WGT
Hang Bars		
WS-HB18	18" Hang Bar	3 lbs
WS-HB36	36" Hang Bar	4 lbs



Dust Shelves

MODEL NO.	DIMENSIONS W" x L"	SHIP WGT
Dust Shelves		
WS-1218DS	12" x 18"	5 lbs
WS-1236DS	12" x 36"	10 lbs
WS-1818DS	18" x 18"	7 lbs
WS-1836DS	18" x 36"	15 lbs



Louvered Panels

MODEL NO.	DIMENSIONS L" x H"	SHIP WGT
Beige Louvered Panels		
QLP-1861BG	18" x 61"	21 lbs
QLP-3661BG	36" x 61"	40 lbs
QLP-4861BG	48" x 61"	60 lbs

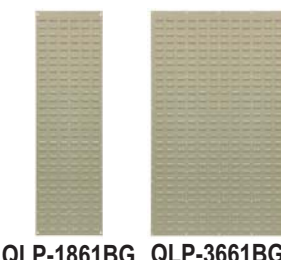

LOWEST PRICE GUARANTEED!



1017HBC



1635HBC

Dividers

Separate product in basket with use of optional dividers. Dividers can be used front to back or side to side in order to create individual compartments. Available in four sizes.



MODEL NO.	DIMENSIONS W" x H"	SHIP WGT
Hanging Basket Dividers		
4X3HBD	3" x 4-1/2"	1 lb
4X6HBD	6" x 4-1/2"	1 lb
4X9HBD	9" x 4-1/2"	1 lb
4X15HBD	15" x 4-1/2"	1 lb

Clear Label Holders

A user friendly method for identifying product. Affixes directly to the front on any basket. Three lengths available.



MODEL NO.	DESCRIPTION	SHIP WGT
Clear Label Holders		
BLH3C	3" Clear Label Holder	1 lb
BLH14C	14" Clear Label Holder	1 lb
BLH32C	32" Clear Label Holder	1 lb

NEW! Q-PEG WALL SYSTEMS

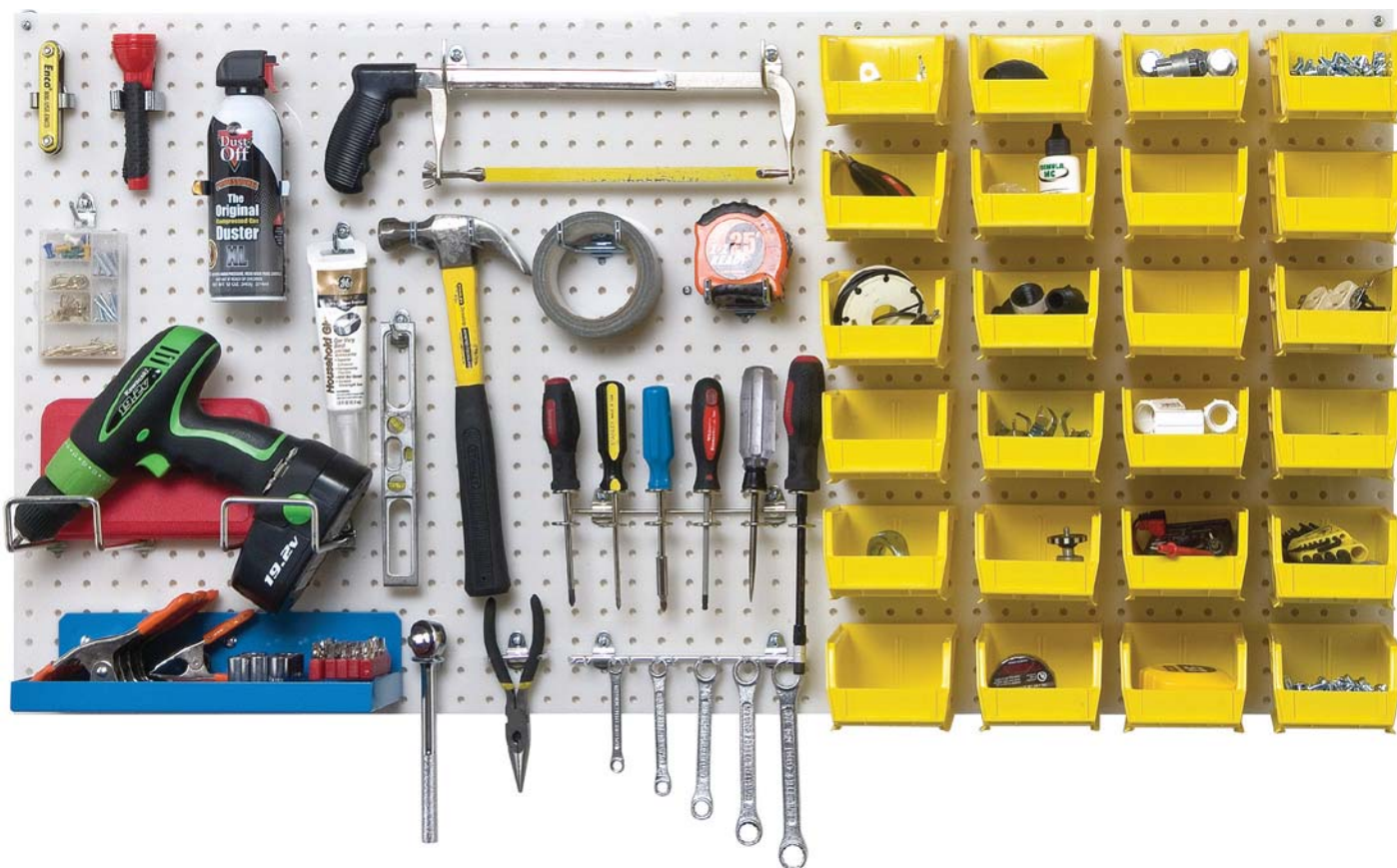

Q-Peg Wall Systems

Quantum's Q-Peg Wall System starts with a heavy-duty Q-Peg Board which is durable, weather resistant and washable. This 1/4" thick, polypropylene board offers 3 times the holding power of traditional peg boards. Available in White.

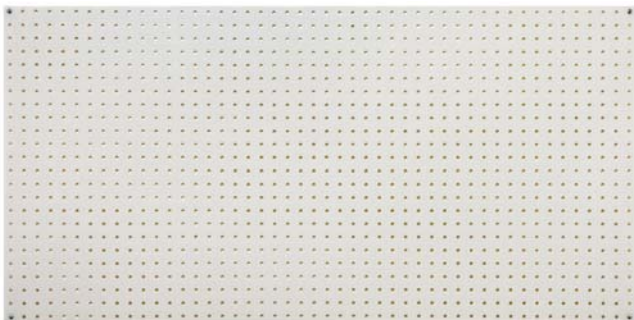

(1) PB-24X48-2

Spacer Kits

Installation of Quantum's Q-Peg heavy-duty Wall System is easy with use of optional spacer kits. These kits create a small gap between the wall and board to allow for accessory installation. Kits do not require any special tools.

Each kit includes:

- 15 - #12, 2" length wood screws
- 15 - Plastic wall anchors
- 15 - 3/8" steel wall spacers



MODEL NO.	DESCRIPTION	CTN QTY	CTN WGT
Q-Peg Wall Mount Board			
PB-24X48-2	24" x 48" x 1/4" Polypropylene Board	2	21 lbs
PB-24X48-4	24" x 48" x 1/4" Polypropylene Board	4	39 lbs
PB-SPACER-KT	Spacer Kit	15	1 lb

Q-Peg Hooks and Accessories

Q-Peg Hooks and accessories can also be mounted on any standard 1/8" or 1/4" pegboard. All hooks can be mounted in different and unique positions to accommodate mostly anything. This unique and patented double locking system ensures all hardware will stay put and never fall out even after repetitive use or relocation. All accessories are listed on the opposite page.

ULTRA Hang Bin Kits

Store supplies and tools with these popular bin sizes. Bin kits include bins and bin clips. Bins are available in Blue, Green, Ivory, Red, Yellow, Black and Clear. See chart on opposite page for ordering instructions. Optional bin dividers, windows and clear label holders are available on page 13.

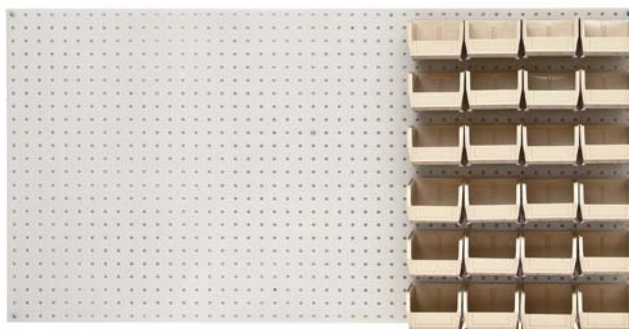

(1) PB-24X48-2 + PB-C-QUS220

PERFORMANCE FEATURES:

- Systems offer 3 times the strength of traditional pegboard
- Q-Peg board is durable, weather resistant and washable
- Wide selection of accessories available to customize your unit



NEW! Q-PEG WALL SYSTEM ACCESSORIES

Accessories



A B C D E F G H I J K

Bin Clips and Rails



L M

Bin Kits

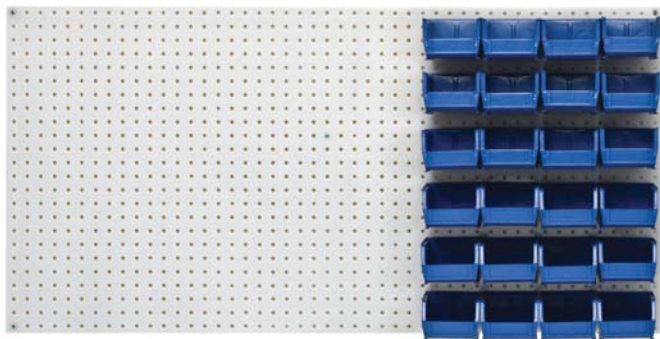

(1) PB-24X48-2 + PB-C-QUS220CL



(1) PB-24X48-2 + PB-C-QUS230CL

Bins



QUS220

QUS230

QUS210

QUS200

MODEL NO.	DESCRIPTION	CTN QTY	CTN WGT
Accessories			
A	PB-1X90-SR 1-1/8" Single Rod, 90° Bend	10	1 lb
	PB-1X30-SR 1" Single Rod, 30° Bend	10	1 lb
	PB-2X30-SR 2-1/2" Single Rod, 30° Bend	10	1 lb
	PB-2X90-SR 2-3/4" Single Rod, 90° Bend	10	2 lbs
	PB-4X30-SR 4" Single Rod, 30° Bend	10	1 lb
	PB-6X30-SR 6" Single Rod, 30° Bend	10	2 lbs
	PB-6X90-SR 6" Single Rod, 90° Bend	10	2 lbs
	PB-8X30-SR 8" Single Rod, 30° Bend	5	2 lbs
B	PB-1X1-PH 1-3/16" x 3/4" Plier Holder	10	1 lb
C	PB-3X80-DR 3" Double Rod, 80° Bend	10	1 lb
	PB-6X80-DR 6" Double Rod, 80° Bend	10	2 lbs
	PB-8X80-DR 8" Double Rod, 80° Bend	5	3 lbs
D	PB-HSC-SM 1/8" - 1/4" Spring Hold Clip	10	1 lb
	PB-HSC-XL 3/4" - 1-1/4" Spring Hold Clip	10	1 lb
	PB-HSC-MD 1/4" - 1/2" Spring Hold Clip	10	1 lb
	PB-HSC-LG 1/2" - 1" Spring Hold Clip	10	1 lb
	PB-SCH-SC Spring Clip, Spray Can Holder	5	1 lb
E	PB-SRTH Single Ring Tool Holder	10	1 lb
	PB-DRTH Double Ring Tool Holder	10	2 lbs
F	PB-2-CH 2-1/4" Curved Hook	10	1 lb
	PB-3-CH 3-3/4" Curved Hook	10	2 lbs
G	PB-6X12SHELF 12" x 6-1/2" Shelf	1	4 lbs
H	PB-3-DMU 3" Double Mounted U Shaped	5	1 lb
I	PB-5-DCEL 5" Double Closed End Loop	5	1 lb
	PB-8-DCEL 8" Double Closed End Loop	5	2 lbs
J	PB-MP-TWH Multi-Prong Tool / Wrench Holder	5	2 lbs
K	PB-MC-TSH Multi-Circle Tool / Screwdriver Holder	2	2 lbs
Bin Clips and Rails			
L	PB-BINCLIP Pegboard Bin Clip (1 clip required per bin)	5	1 lb
M	HNS006 12" Plastic Rail	2	1 lb

MODEL NO.	NO. OF BINS/HOOKS	BIN DIMENSIONS L" x W" x H"	CTN QTY	CTN WGT
Bin Kits - Available in Blue, Yellow, Red, Green, Ivory or Black				
PB-C-QUS200	24	5" x 4-1/8" x 3"	24	8 lbs
PB-C-QUS210	24	5-3/8" x 4-1/8" x 3"	24	8 lbs
PB-C-QUS220	24	7-3/8" x 4-1/8" x 3"	24	11 lbs
PB-C-QUS230	12	10-7/8" x 5-1/2" x 5"	12	12 lbs
Clear Bin Kits				
PB-C-QUS200CL	24	5" x 4-1/8" x 3"	24	8 lbs
PB-C-QUS210CL	24	5-3/8" x 4-1/8" x 3"	24	8 lbs
PB-C-QUS220CL	24	7-3/8" x 4-1/8" x 3"	24	11 lbs
PB-C-QUS230CL	12	10-7/8" x 5-1/2" x 5"	12	12 lbs



VERSATILE WALL STORAGE SOLUTION

CANTILEVER WALL MOUNT SYSTEMS

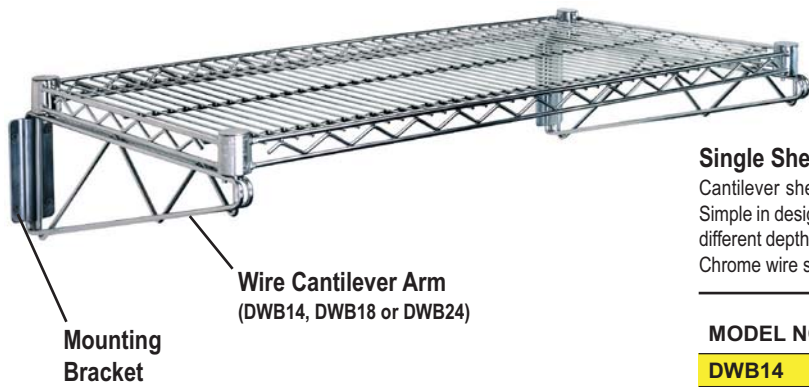

Wire Cantilever Arm
(DWB14, DWB18 or DWB24)

Mounting Bracket

Single Shelf Wall Mount

Cantilever shelving is an excellent way to create storage space when floor space isn't available. Simple in design, our cantilever shelving systems are easy to assemble and install. Select from three different depths: 14", 18" or 24". Two cantilever arms and 2 mounting brackets are included per order. Chrome wire shelves are sold separately and are available on [page 88](#).

MODEL NO.	DESCRIPTION	SHIP WGT
DWB14	2 - 14" cantilever arms & 2 mounting brackets	3 lbs
DWB18	2 - 18" cantilever arms & 2 mounting brackets	4 lbs
DWB24	2 - 24" cantilever arms & 2 mounting brackets	5 lbs

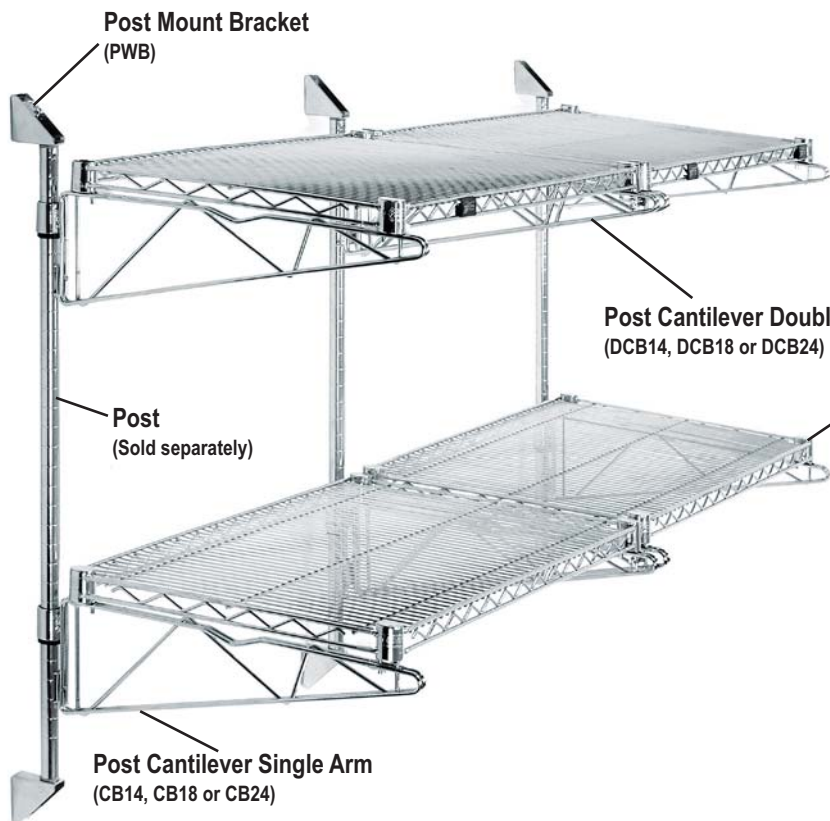

Post Mount Bracket
(PWB)

Post Cantilever Double Arm
(DCB14, DCB18 or DCB24)

Post
(Sold separately)

Post Cantilever Single Arm
(CB14, CB18 or CB24)

LOWEST PRICE GUARANTEED!

TO ORDER THIS EXACT CONFIGURATION, YOU WOULD ORDER THE FOLLOWING:

- 2 - CB18
- 2 - DCB18
- 4 - 1836C
- 3 - P34C

To further extend the configuration shown by an additional section to the left or right, simply order:

- 2 - DCB18
- 2 - 1836C
- 1 - P34C

To further extend the configuration shown by an additional shelf level, simply order:

- 1 - CB18
- 1 - DCB18
- 2 - 1836C

Your options are unlimited!

Multiple Shelf Post Wall Mount - Adjustable on 1" increments

Adjustable post wall mount systems use a post cantilever single arm of 14", 18" or 24" with appropriate shelf size and post height. Two post cantilever single arms and 4 post mount brackets are included per order.

Post Cantilever Double Arm is available in 14", 18" and 24" and uses the center post for continuous or add-on shelf sections. One post cantilever double arm and 2 post mount brackets are included per order. Wire shelves and posts are sold separately and available on [pages 88-89](#).



Post Mount Bracket
Model No.: PWB

Used to secure cantilever post mount units and free standing shelving units to wall. Sold in a pack of 4. (Mounting screws are not included)

MODEL NO.	DESCRIPTION	SHIP WGT
Single Post Cantilever Arms		
CB14	2 - 14" single post cantilever arms & 4 post mount brackets	5 lbs
CB18	2 - 18" single post cantilever arms & 4 post mount brackets	6 lbs
CB24	2 - 24" single post cantilever arms & 4 post mount brackets	7 lbs
Double Post Cantilever Arms		
DCB14	1 - 14" double post cantilever arm & 2 post mount brackets	10 lbs
DCB18	1 - 18" double post cantilever arm & 2 post mount brackets	12 lbs
DCB24	1 - 24" double post cantilever arm & 2 post mount brackets	14 lbs

CANTILEVER WALL MOUNT - COMPLETE PACKAGES



CAN-34-60BH-230



CAN-34-36BH-230

COMPLETE PACKAGES

with bins!



Post Wall Mount Cantilever with Bin Holders - Complete Packages

Easy and adjustable wall mounted bin systems. Available in 36", 48" and 60" widths. Bins available in Blue, Green, Ivory, Red, Yellow, Black and Clear. Optional bin dividers, windows and clear label holders are available on page 13.

MODEL NO.	NO. OF BIN HOLDERS	DIMENSIONS L" x H"	NO. OF BINS	BIN DIMENSIONS L" x W" x H"	SHIP WGT
Wire Cantilever Bin Holder -- Complete with Bins Available in Blue, Green, Ivory, Red, Yellow, Black and Clear					
CAN-34-36BH-230	3	36" x 34"	18 QUS230	10-7/8" x 5-1/2" x 5"	26 lbs
CAN-34-48BH-230	3	48" x 34"	24 QUS230	10-7/8" x 5-1/2" x 5"	34 lbs
CAN-34-60BH-230	3	60" x 34"	30 QUS230	10-7/8" x 5-1/2" x 5"	42 lbs



149DC

Shown on Basket

Basket Dividers

Optional dividers can be used to separate product. Finish: Chrome

DIVIDER MODEL NO.	DIMENSIONS L" x H"	SHIP WGT
149DC	14" x 9"	1 lb
209DC	20" x 9"	2 lbs
2012DC	20" x 12"	2 lbs



CAN-34-1436BC-PWB

Post Wall Mount Cantilever with Baskets - Complete Packages

Modular Wire Baskets mount to standard post to utilize wall space efficiently. Baskets allow for high visibility and quick accessibility. Baskets are adjustable and removable. Finish: Chrome

MODEL NO.	NO. OF BASKETS	BASKET MODEL NO.	BASKET DIMENSIONS W" x L" x H"	SHIP WGT
34"H Wire Cantilever with Baskets -- Complete Packages				
CAN-34-1436BC-PWB	2	1436BC	14" x 36" x 9"	26 lbs
CAN-34-1448BC-PWB	2	1448BC	14" x 48" x 9"	32 lbs
CAN-34-2036BC-PWB	2	2036BC	20" x 36" x 9"	30 lbs
CAN-34-2048BC-PWB	2	2048BC	20" x 48" x 9"	36 lbs
CAN-34-203612BC-PWB	2	203612BC	20" x 36" x 12"	34 lbs
CAN-34-204812BC-PWB	2	204812BC	20" x 48" x 12"	38 lbs

COMPLETE PACKAGES
with baskets!

NEW! GRID-STORE WALL MOUNTED SYSTEMS

Grid-Store Wall Mounted Systems

Quantum's new Grid-Store System provides a strong, versatile solution for organization and storage of small, medium and large supplies. A wide selection of accessories allow for easy storage of items ranging from catheters to crutches. Heavy-duty wall brackets firmly secure panels to walls or any flat surface. Heavy gauge wire grid (1/4" rod) construction allows for secure storage as well as visibility and dust and dirt free storage. Durable white gloss finish is aesthetically pleasing. Grid hooks and accessories are fabricated using 1/4" diameter wire, allowing heavy-duty application storage.

Grid-Store Hooks

Each hook is a full 1/4" in diameter and ideal for hanging prepackaged items. Available in 2 lengths.

Grid-Store Hook Tube with 5 hooks

16" Rectangular tubing with 5 hooks.

Grid-Store Slanted Shelf

Slanted shelf allows you to display products higher up yet still easy to see. Measures 15-1/4"L x 22-3/8"W.

Grid-Store Baskets

12"L x 12"W x 8"H baskets, one also available with a 4" front lip allowing easy access to items stored.

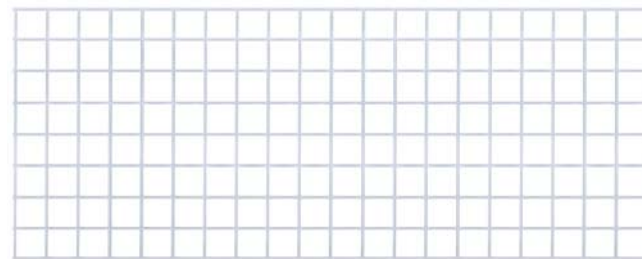
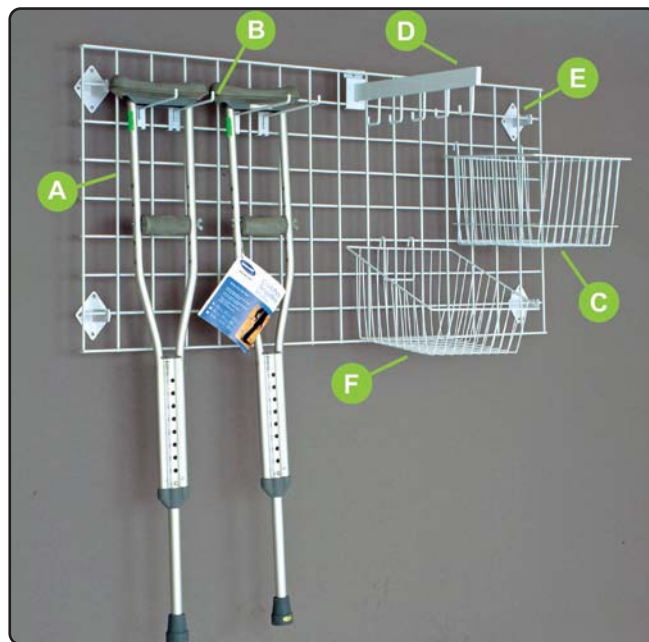

GSP-2448

MODEL NO.	DESCRIPTION	CTN QTY	CTN WGT
Grid Panels			
A GSP-2448	24" x 48" Grid-Store Panel	1	12 lbs
GSP-2460	24" x 60" Grid-Store Panel	1	15 lbs
GSP-2472	24" x 72" Grid-Store Panel	1	17 lbs
Grid Panels Accessories			
B GSP-HOOK6	6" Grid-Store Hook	1	1 lb
GSP-HOOK10	10" Grid-Store Hook	1	1 lb
C GSP-B12128	12" x 12" x 8" Grid-Store Basket	1	3 lbs
D GSP-5HOOK-16	16" Rectangular Tube w/ 5 Hooks	1	2 lbs
E GSP-WMHD	Heavy-Duty Wall Mounting Bracket	1	1 lb
F GSP-SB12128	12" x 12" x 8" Slanted Grid-Store Basket	1	2 lbs
G GSP-SS2215	22-3/8" x 15-1/4" Slanted Shelf	1	4 lbs

ACCESSORIES

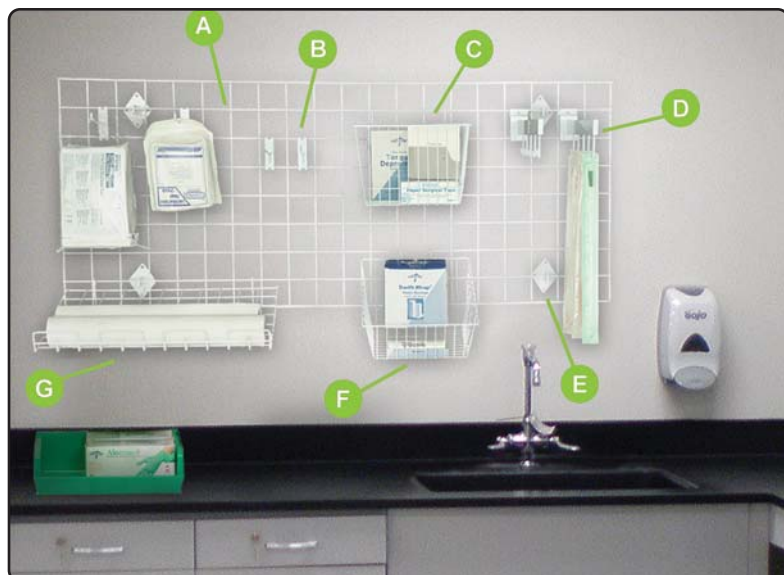

GSP-Hooks 6" and 10"



GSP-B12128



GSP-5HOOK-16



GSP-WMHD



GSP-SB12128

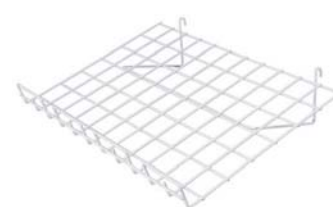

GSP-SS2215

STEM CASTER CARTS

4 Wire Shelf Mobile Cart

Mobile wire stem caster carts add versatility & flexibility to any operation, creating a transport system.

- Central supply & distribution
- Stock rotation
- Laundry
- Staging

Each unit consists of:

- 4 - posts
- 4 - wire shelves
- 4 - donut bumpers
- 4 - 5" poly stem casters, 2 with brakes



M1836C46

MODEL NO.	DIMENSIONS W" x L" x H"	SHIP WGT
63"H Post, 5" Stem Caster Unit		
M1836C46	18" x 36" x 69"	62 lbs
M1848C46	18" x 48" x 69"	70 lbs
M1860C46	18" x 60" x 69"	90 lbs
M2436C46	24" x 36" x 69"	74 lbs
M2448C46	24" x 48" x 69"	86 lbs
M2460C46	24" x 60" x 69"	106 lbs
74"H Post, 5" Stem Caster Unit		
M1836C47	18" x 36" x 80"	64 lbs
M1848C47	18" x 48" x 80"	72 lbs
M1860C47	18" x 60" x 80"	92 lbs
M2436C47	24" x 36" x 80"	76 lbs
M2448C47	24" x 48" x 80"	88 lbs
M2460C47	24" x 60" x 80"	108 lbs

3 Wire / 1 Solid Shelf Mobile Cart

Stem caster cart with solid bottom shelf. The unique combination of wire and solid shelves allows for air circulation & high visibility. The solid shelf in the bottom position prevents dust and dirt to rise and contains spillage.

Each unit consists of:

- 4 - posts
- 3 - wire shelves
- 1 - solid shelf
- 4 - donut bumpers
- 4 - 5" poly stem casters, 2 with brakes



M1836CG46

MODEL NO.	DIMENSIONS W" x L" x H"	SHIP WGT
63"H Post, 5" Stem Caster Unit		
M1836CG46	18" x 36" x 69"	68 lbs
M1848CG46	18" x 48" x 69"	76 lbs
M1860CG46	18" x 60" x 69"	97 lbs
M2436CG46	24" x 36" x 69"	80 lbs
M2448CG46	24" x 48" x 69"	94 lbs
M2460CG46	24" x 60" x 69"	116 lbs
74"H Post, 5" Stem Caster Unit		
M1836CG47	18" x 36" x 80"	70 lbs
M1848CG47	18" x 48" x 80"	78 lbs
M1860CG47	18" x 60" x 80"	99 lbs
M2436CG47	24" x 36" x 80"	82 lbs
M2448CG47	24" x 48" x 80"	96 lbs
M2460CG47	24" x 60" x 80"	118 lbs

4 Solid Shelf Mobile Cart

Stem caster solid shelf cart is an easy way to transport fluids & small packaged items.

Each unit consists of:

- 4 - posts
- 4 - solid shelves
- 4 - donut bumpers
- 4 - 5" poly stem casters, 2 with brakes



M1836SG46

MODEL NO.	DIMENSIONS W" x L" x H"	SHIP WGT
63"H Post, 5" Stem Caster Unit		
M1836SG46	18" x 36" x 69"	86 lbs
M1848SG46	18" x 48" x 69"	102 lbs
M1860SG46	18" x 60" x 69"	118 lbs
M2436SG46	24" x 36" x 69"	98 lbs
M2448SG46	24" x 48" x 69"	102 lbs
M2460SG46	24" x 60" x 69"	146 lbs
74"H Post, 5" Stem Caster Unit		
M1836SG47	18" x 36" x 80"	88 lbs
M1848SG47	18" x 48" x 80"	104 lbs
M1860SG47	18" x 60" x 80"	120 lbs
M2436SG47	24" x 36" x 80"	100 lbs
M2448SG47	24" x 48" x 80"	104 lbs
M2460SG47	24" x 60" x 80"	148 lbs

ENCLOSURE CARTS

Enclosure Linen Carts

Finish: Chrome

Each unit consists of:

- 4 - posts
- 4 - wire shelves
- 4 - enclosure panels
- 4 - 5" swivel poly stem casters, 2 with brakes
- 4 - donut bumpers

3 Sided, 4 Wire Shelf Cart with Enclosure Panels

MODEL NO.	DIMENSIONS W" x L" x H"	SHIP WGT
63"H Post, Unit with Enclosure Panels		
M2436C46E	24" x 36" x 69"	145 lbs
M2448C46E	24" x 48" x 69"	179 lbs
M2460C46E	24" x 60" x 69"	197 lbs



M2436C46E

**COMPLETE
CARTS
INCLUDE
caster kit for
mobility!**



M1836C46RE

3 Sided, 4 Wire Shelf Cart with Rods & Tabs

MODEL NO.	DIMENSIONS W" x L" x H"	SHIP WGT
63"H Post, Unit with Rods and Tabs		
M1836C46RE	18" x 36" x 69"	74 lbs
M1848C46RE	18" x 48" x 69"	84 lbs
M1860C46RE	18" x 60" x 69"	100 lbs
M2436C46RE	24" x 36" x 69"	88 lbs
M2448C46RE	24" x 48" x 69"	104 lbs
M2460C46RE	24" x 60" x 69"	124 lbs
74"H Post, Unit with Rods and Tabs		
M1836C47RE	18" x 36" x 80"	80 lbs
M1848C47RE	18" x 48" x 80"	92 lbs
M1860C47RE	18" x 60" x 80"	104 lbs
M2436C47RE	24" x 36" x 80"	94 lbs
M2448C47RE	24" x 48" x 80"	112 lbs
M2460C47RE	24" x 60" x 80"	132 lbs

Enclosure Carts

Enclosure carts are an effective way to keep contents from moving or falling off during transportation.

Enclosure carts using rods and tabs are adaptable to any shelf position.

Enclosure dolly base truck using rods & tabs allows for heavier load transport. The rods & tabs act as a perimeter to retain product.

For additional shelves, refer to [page 88](#).



**LOWEST
PRICE
GUARANTEED!**

All units consist of:

- 4 - posts
- 4 - wire shelves
- 4, 5 or 6 - rods & tabs kits

Mobile unit also includes:

- 4 - 5" swivel poly stem casters, 2 with brakes
- 4 - donut bumpers

Dolly Base unit also includes:

- 1 - dolly base
- 4 - plate casters (2 rigid and 2 swivel with brake)



MD1836C46RE

Dolly Base 3 Sided, 4 Wire Shelf Cart with Rods & Tabs

MODEL NO.	DIMENSIONS W" x L" x H"	SHIP WGT
63"H Post, Dolly Base Unit		
MD1836C46RE	18" x 36" x 70"	86 lbs
MD1848C46RE	18" x 48" x 70"	96 lbs
MD1860C46RE	18" x 60" x 70"	124 lbs
MD2436C46RE	24" x 36" x 70"	113 lbs
MD2448C46RE	24" x 48" x 70"	121 lbs
MD2460C46RE	24" x 60" x 70"	144 lbs
74"H Post, Dolly Base Unit		
MD1836C47RE	18" x 36" x 81"	92 lbs
MD1848C47RE	18" x 48" x 81"	106 lbs
MD1860C47RE	18" x 60" x 81"	120 lbs
MD2436C47RE	24" x 36" x 81"	108 lbs
MD2448C47RE	24" x 48" x 81"	129 lbs
MD2460C47RE	24" x 60" x 81"	152 lbs



M1836CG46RE

3 Sided Stem Caster Wire Shelf Cart with 3 Wire Shelves and 1 Solid Shelf with Rods & Tabs

**COMPLETE
CARTS
INCLUDE
caster kit for
mobility!**



**LOWEST
PRICE
GUARANTEED!**



MD1836CG46RE

Dolly Base 3 Sided Wire Shelf Cart with 3 Wire Shelves and 1 Solid Shelf with Rods & Tabs

MODEL NO.	DIMENSIONS W" x L" x H"	SHIP WGT
63"H Post, Unit with Rods and Tabs		
M1836CG46RE	18" x 36" x 69"	83 lbs
M1848CG46RE	18" x 48" x 69"	94 lbs
M1860CG46RE	18" x 60" x 69"	114 lbs
M2436CG46RE	24" x 36" x 69"	96 lbs
M2448CG46RE	24" x 48" x 69"	112 lbs
M2460CG46RE	24" x 60" x 69"	136 lbs
74"H Post, Unit with Rods and Tabs		
M1836CG47RE	18" x 36" x 80"	89 lbs
M1848CG47RE	18" x 48" x 80"	101 lbs
M1860CG47RE	18" x 60" x 80"	123 lbs
M2436CG47RE	24" x 36" x 80"	102 lbs
M2448CG47RE	24" x 48" x 80"	119 lbs
M2460CG47RE	24" x 60" x 80"	145 lbs

MODEL NO.	DIMENSIONS W" x L" x H"	SHIP WGT
63"H Post, Unit with Rods and Tabs		
MD1836CG46RE	18" x 36" x 70"	93 lbs
MD1848CG46RE	18" x 48" x 70"	106 lbs
MD1860CG46RE	18" x 60" x 70"	128 lbs
MD2436CG46RE	24" x 36" x 70"	109 lbs
MD2448CG46RE	24" x 48" x 70"	127 lbs
MD2460CG46RE	24" x 60" x 70"	154 lbs
74"H Post, Unit with Rods and Tabs		
MD1836CG47RE	18" x 36" x 81"	99 lbs
MD1848CG47RE	18" x 48" x 81"	113 lbs
MD1860CG47RE	18" x 60" x 81"	137 lbs
MD2436CG47RE	24" x 36" x 81"	115 lbs
MD2448CG47RE	24" x 48" x 81"	134 lbs
MD2460CG47RE	24" x 60" x 81"	163 lbs

All units consist of:

- 4 - posts
- 3 - wire shelves
- 1 - solid shelf
- 4, 5 or 6 - rods & tabs kits

Mobile unit also includes:

- 4 - 5" swivel poly stem casters, 2 with brakes
- 4 - donut bumpers

Dolly Base unit also includes:

- 1 - dolly base
- 4 - plate casters (2 rigid and 2 swivel with brake)

Rods & Tabs

Rods & tabs represent an economical, alternate solution for enclosure on backs and sides of mobile and stationary units. Each kit includes 3 rods, 9 front/back tabs and 9 side tabs.

MODEL NO.	DESCRIPTION	SHIP WGT
Rods & Tabs		
52RT	3 - 52" Rods with tabs	1 lb
61RT	3 - 61" Rods with tabs	1 lb
72RT	3 - 72" Rods with tabs	2 lbs
84RT	3 - 84" Rods with tabs	2 lbs

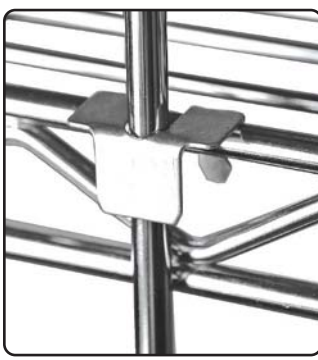

QSRT
Side Tab & Solid Shelf Tab



QAT
Front/Back Tab

LINEN & BIN TRANSPORT CARTS

Bin Transport Cart

Modular in design, the Bin Transport Cart provides an integrated system to transfer items. Carts enable you to color code, hold or transport inventories and supplies. Ideal for use in central supply and laundry. Bins are autoclavable up to 250°F. Bins available in Blue, Red and Yellow. Cart finish: Chrome

MODEL NO.	NO. OF SHELVES	NO. OF BINS	BIN DIMENSIONS L" x W" x H"	SHIP WGT
30"x 36" x 69" Wire Shelving Unit with HULK Containers				
WRC2-63-3036-974976	2	2	29-7/8" x 16-1/2" x 11"	150 lbs
		6	29-7/8" x 16-1/2" x 15"	
30"x 36" x 42" Wire Shelving Unit with HULK Containers				
WRC2-36-3036-976	2	4	29-7/8" x 16-1/2" x 15"	88 lbs



WRC2-36-3036-976

**COMPLETE
PACKAGES
with bins!**



WRCS64-63-2436EP

**3 Sided Stem Caster Linen Cart
with 3 Wire Shelves and 1 Solid Shelf
with Enclosure Panels**



WRC2-63-3036-974976

**COMPLETE
CARTS
INCLUDE
caster kit for
mobility!**

Fastest
Shipping
IN THE INDUSTRY

**LOWEST
PRICE
GUARANTEED!**



WRDBS64-63-2436EP

**3 Sided Dolly Base Linen Cart
with 3 Wire Shelves and 1 Solid Shelf
with Enclosure Panels**

MODEL NO.	DIMENSIONS W" x L" x H"	SHIP WGT
63"H Post, 5" Stem Caster Unit with Solid Bottom Shelf and Enclosure Panels		
WRCS4-63-2436EP	24" x 36" x 69"	113 lbs
WRCS4-63-2448EP	24" x 48" x 69"	131 lbs
WRCS4-63-2460EP	24" x 60" x 69"	158 lbs
74"H Post, 5" Stem Caster Unit with Solid Bottom Shelf and Enclosure Panels		
WRCS4-74-2436EP	24" x 36" x 80"	113 lbs
WRCS4-74-2448EP	24" x 48" x 80"	131 lbs
WRCS4-74-2460EP	24" x 60" x 80"	158 lbs

All units consist of:

- 4 - posts
- 3 - wire shelves
- 1 - solid shelf
- 4 - enclosure panels

Mobile unit also includes:

- 4 - 5" swivel poly stem casters,
2 with brakes
- 4 - donut bumpers

Dolly Base unit also includes:

- 1 - dolly base
- 4 - plate casters (2 rigid and
2 swivel with brake)

MODEL NO.	DIMENSIONS W" x L" x H"	SHIP WGT
63"H Post, Dolly Base Cart with Solid Bottom Shelf and Enclosure Panels		
WRDBS4-63-2436EP	24" x 36" x 70"	124 lbs
WRDBS4-63-2448EP	24" x 48" x 70"	142 lbs
WRDBS4-63-2460EP	24" x 60" x 70"	169 lbs
74"H Post, Dolly Base Cart with Solid Bottom Shelf and Enclosure Panels		
WRDBS4-74-2436EP	24" x 36" x 81"	124 lbs
WRDBS4-74-2448EP	24" x 48" x 81"	142 lbs
WRDBS4-74-2460EP	24" x 60" x 81"	169 lbs

Chrome Security Units

Stationary and Mobile Units prevent pilferage while allowing high visibility of contents at all times. All side and back panels are heavy gauge wire construction and are manufactured of all-welded heavy-duty 1/4" diameter wire on 2" x 2" centers. Assembly is quick and easy. Finish: Chrome

Stationary Security Units

Additional intermediate shelves can be purchased separately, see page 88. Finish: Chrome

MODEL NO.	DIMENSIONS W" x L" x H"	SHIP WGT
Stationary Security Units		
2436-63SEC	24" x 36" x 63"	165 lbs
2448-63SEC	24" x 48" x 63"	192 lbs
2460-63SEC	24" x 60" x 63"	224 lbs



2436-63SEC

- Each unit consists of:**
- 4 - posts
 - 2 - wire shelves
(for top and bottom)
 - 1 - security panel set
(includes back and sides)
 - 1 - pair security panel doors



M2436-69SEC



**LOWEST
PRICE
GUARANTEED!**

- Each unit consists of:**
- 4 - posts
 - 2 - wire shelves
(for top and bottom)
 - 1 - security panel set
(includes back and sides)
 - 1 - pair security panel doors

- Mobile unit also includes:**
- 4 - 5" poly stem casters,
2 with brakes
 - 4 - donut bumpers

- Dolly Base unit also includes:**
- 1 - mobile dolly
 - 4 - plate casters (2 rigid and
2 swivel with brake)

Stem Castered Security Units

Mobility adds flexibility to a unit and is beneficial in all types of operations. Additional intermediate shelves can be purchased separately, see page 88. Finish: Chrome

MODEL NO.	DIMENSIONS W" x L" x H"	SHIP WGT
Stem Caster Security Units		
M2436-69SEC	24" x 36" x 69"	173 lbs
M2448-69SEC	24" x 48" x 69"	200 lbs
M2460-69SEC	24" x 60" x 69"	232 lbs



MD2436-70SEC

Dolly Base Security Units

Dollies can add stability and support in heavy-duty load applications. Additional intermediate shelves can be purchased separately, see page 88. Finish: Chrome

MODEL NO.	DIMENSIONS W" x L" x H"	SHIP WGT
Dolly Base Security Units		
MD2436-70SEC	24" x 36" x 70"	186 lbs
MD2448-70SEC	24" x 48" x 70"	215 lbs
MD2460-70SEC	24" x 60" x 70"	250 lbs

Security Panels

Panels allow maximum security for standard shelving units. Panels are fabricated from all-welded wire and include joined back portion and two side portions.

MODEL NO.	DIMENSIONS W" x L" x H"	SHIP WGT
Security Enclosure Panels		
243660EPC	24" x 36" x 60"	70 lbs
244860EPC	24" x 48" x 60"	80 lbs
246060EPC	24" x 60" x 60"	90 lbs

**Want to
SECURE your
existing
shelving unit?**

Security Panel Doors

Each door set has left and right panel with 4 hinge bars. Assembly is quick and easy and adapts to the appropriate shelf size, with our standard post of 63" in height.

MODEL NO.	DIMENSIONS W" x L" x H"	SHIP WGT
Security Panel Door Set with Hinges		
SD36C	24" x 36" x 60"	54 lbs
SD48C	24" x 48" x 60"	66 lbs
SD60C	24" x 60" x 60"	78 lbs

WIRE SHELVING COVERS



White Nylon



COVERS PROTECT AGAINST PILFERAGE, AIRBORNE DUST, WATER AND OTHER CONTAMINANTS!

TO ORDER:

1. Choose size
2. Select color:
Clear Vinyl add suffix **CV**
Blue Nylon add suffix **BN**
White Nylon add suffix **WN**
3. Choose Zipper or Velcro



Blue Nylon



LOWEST PRICE GUARANTEED!



Clear Vinyl

PROTECT AGAINST PILFERAGE, AIRBORNE DUST, WATER AND OTHER CONTAMINANTS!

Wire Cart Covers

Protect against pilferage, airborne dust, water and other contaminants. Velcro and zipper flap are available in clear-vinyl and blue and white denier fabric. Clear vinyl is 10 ga. Blue and white nylon is 400 Denier. Specify zipper or velcro for closure. Custom sizes are available, call for more information.

63"H CART COVER				74"H CART COVER			
DIMENSIONS	SHIP WGT	400 DENIER	CLEAR VINYL	DIMENSIONS	SHIP WGT	400 DENIER	CLEAR VINYL
		MODEL NO.	MODEL NO.			MODEL NO.	MODEL NO.
18" x 36" x 63"	3 lbs	CC183663	CC183663CV	18" x 36" x 74"	4 lbs	CC183674	CC183674CV
18" x 48" x 63"	4 lbs	CC184863	CC184863CV	18" x 48" x 74"	5 lbs	CC184874	CC184874CV
18" x 60" x 63"	5 lbs	CC186063	CC186063CV	18" x 60" x 74"	6 lbs	CC186074	CC186074CV
18" x 72" x 63"	6 lbs	CC187263	CC187263CV	18" x 72" x 74"	7 lbs	CC187274	CC187274CV
24" x 36" x 63"	3 lbs	CC243663	CC243663CV	24" x 36" x 74"	4 lbs	CC243674	CC243674CV
24" x 48" x 63"	4 lbs	CC244863	CC244863CV	24" x 48" x 74"	5 lbs	CC244874	CC244874CV
24" x 60" x 63"	5 lbs	CC246063	CC246063CV	24" x 60" x 74"	6 lbs	CC246074	CC246074CV
24" x 72" x 63"	6 lbs	CC247263	CC247263CV	24" x 72" x 74"	7 lbs	CC247274	CC247274CV

UTILITY



WRC-1836-2CG



WRC-1836-3CG



WRC-1836-2G



WRC-1836-3G

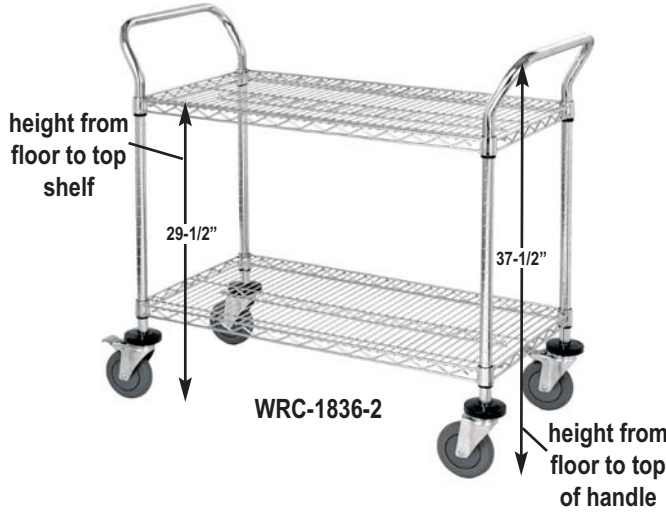

WRC-1836-2



WRC-1836-3



(Cylinders not included)

WRC-IT1824

Cylinder Transport / Inhalation Therapy Cart

Mobile unit can transport up to 12 of the D and/or E cylinders. Protective vinyl coated wires separate and protect cylinders. Unit consists of two u-handles, 4 donut bumpers, 4 conductive swivel casters (2 with brakes), 1 wire shelf and 2 frames with coated wire grid shelves. Wire finish: Chrome

MODEL NO.	SHIP WGT
Mobile Cylinder Cart 18" x 24" x 37-1/2"	
WRC-IT1824	45 lbs



Wire Utility Carts

Give versatility to any operation: food service, hospitals and maintenance. Carts consists of 2 u-handles, 4 donut bumpers, 4 swivel casters (2 with brakes) and wire or solid shelf combinations.

DIMENSIONS W" x L" x H"	WIRE SHELF		WIRE & SOLID SHELF		SOLID SHELF	
	MODEL NO.	SHIP WGT	MODEL NO.	SHIP WGT	MODEL NO.	SHIP WGT
	2 Wire Shelf Mobile Utility Cart		1 Wire & 1 Solid Shelf Mobile Utility Cart		2 Solid Shelf Mobile Utility Cart	
18" x 36" x 37-1/2"	WRC-1836-2	30 lbs	WRC-1836-2CG	37 lbs	WRC-1836-2G	44 lbs
18" x 42" x 37-1/2"	WRC-1842-2	32 lbs	--	--	--	--
18" x 48" x 37-1/2"	WRC-1848-2	37 lbs	WRC-1848-2CG	45 lbs	WRC-1848-2G	56 lbs
24" x 36" x 37-1/2"	WRC-2436-2	36 lbs	WRC-2436-2CG	42 lbs	WRC-2436-2G	48 lbs
24" x 42" x 37-1/2"	WRC-2442-2	40 lbs	--	--	--	--
24" x 48" x 37-1/2"	WRC-2448-2	44 lbs	WRC-2448-2CG	52 lbs	WRC-2448-2G	60 lbs
	3 Wire Shelf Mobile Utility Cart		2 Wire & 1 Solid Shelf Mobile Utility Cart		3 Solid Shelf Mobile Utility Cart	
18" x 36" x 37-1/2"	WRC-1836-3	37 lbs	WRC-1836-3CG	46 lbs	WRC-1836-3G	60 lbs
18" x 42" x 37-1/2"	WRC-1842-3	42 lbs	--	--	--	--
18" x 48" x 37-1/2"	WRC-1848-3	48 lbs	WRC-1848-3CG	52 lbs	WRC-1848-3G	76 lbs
24" x 36" x 37-1/2"	WRC-2436-3	49 lbs	WRC-2436-3CG	55 lbs	WRC-2436-3G	67 lbs
24" x 42" x 37-1/2"	WRC-2442-3	55 lbs	--	--	--	--
24" x 48" x 37-1/2"	WRC-2448-3	60 lbs	WRC-2448-3CG	68 lbs	WRC-2448-3G	84 lbs

MODULAR TRAYS & TRAY CARTS

Trays

Heavy duty 18" x 26" white trays are NSF approved for use for food service or may be used for standard applications. Perimeter ends are reinforced for additional strength. New 20" x 26" size offers a deep stacking tray. Both tray sizes are available in ESD complying to ANSI / ESD standards for the use in PC board assembly and handling. All trays are manufactured of fiber-glass reinforced thermostet material, allowing up to 200 lbs. weight capacity when evenly distributed. Quantum's modular trays will withstand temperatures of -40°F to +350°F. 18" x 26" Trays available in White and ESD, 20" x 26" Trays are available in White, Gray and ESD.



2026TRGY



1826TR



1826ESD



Tray Slides

Efficiently utilize space between shelves using standard trays and/or bins.

- Available in 18" and 24" depths
- Accommodates up to 10 trays

MODEL NO.	DIMENSIONS W" x L" x H"	SHIP WGT
18" x 26" Trays		
1826TR	18" x 26" x 1-1/8" White Tray	4 lbs
1826ESD	18" x 26" x 1-1/8" Black ESD Tray	4 lbs
20" x 26" Trays		
2026TRGY	20" x 26" x 1-1/2" Gray Tray	5 lbs
2026TRWT	20" x 26" x 1-1/2" White Tray	5 lbs
2026ESD	20" x 26" x 1-1/2" Black ESD Tray	5 lbs

MODEL NO.	DESCRIPTION	SHIP WGT
Tray Slide		
TS18C	18" Tray Slide Set	10 lbs
TS24C	24" Tray Slide Set	11 lbs



TS62C
Optional Tray
Stop

Genuine Quantum Modular Tray Carts

Tray Carts are offered in half size and full size units, designed to handle work in process. ESD trays can be used on tray cart for conductive applications with the addition of aluminum split sleeves (ESD-SS) and a drag chain (ESD-DC), available on catalog page 125. Optional Tray Stop prevents trays from falling out. Finish: Chrome

MODEL NO.	DIMENSIONS W" x L" x H"	CAPACITY	SHIP WGT	PRICE EACH	TRAY STOP MODEL NO.
39"H Tray Cart					
TC-19	18" x 30" x 39"	19 Trays	45 lbs	\$154.70	TS32C
69"H Tray Carts					
TC-39	18" x 30" x 69"	39 Trays	74 lbs	\$182.00	TS62C
TC-31	21" x 30" x 69"	31 Trays	68 lbs	\$173.41	TS62C

Trays are sold separately.



TC-19
(Trays sold separately)



ESD-DC

Drag chain used to ground standard wire shelving units. Recommended to be used in conjunction with aluminum split sleeves (ESD-SS)



TC-39 + TS62C
Tray Stops can be used on back as shown here or one in the back and one in the front.
(Trays sold separately)

Bin Carts

Modular in design the slide positions are adjustable on 1" centers enabling the cart to work with various bins and/or trays. Finish: Chrome. Dividable Grids available in Red, Blue and Gray.



BC212469M1



BC212434M1



Bin Cart

Bin cart can be used for transporting and holding product. A modular drawer system allows for storage of smaller specialty components while the open shelf design maximizes the storage area. The option of enclosure panels, dividers, ledges and cart covers add to the flexibility of the unit. See pages 124 and 114 for these accessories. Dividable grids are available in Red, Blue and Gray. Cart finish: Chrome

Each unit consists of:

- 4 - 63" posts
- 5 - wire shelves
- 4 - DS18-24 bin slide
- 4 - 5" swivel poly stem casters, 2 with brakes
- 4 - donut bumpers
- 4 - DG93060 bins (Blue, Gray or Red)

MODEL NO.	NO. OF BINS	BIN DIMENSIONS L" x W" x H"	SHIP WGT
24"W x 36"L x 69"H Bin Cart with Dividable Grids			
WRC5-63-2436-93060	4 DG93060	22-1/2" x 17-1/2" x 6"	113 lbs
24"W x 48"L x 69"H Bin Cart with Dividable Grids			
WRC5-63-2448-93060	4 DG93060	22-1/2" x 17-1/2" x 6"	128 lbs
24"W x 60"L x 69"H Bin Cart with Dividable Grids			
WRC5-63-2460-93060	4 DG93060	22-1/2" x 17-1/2" x 6"	153 lbs

Portable Computer / LAN Work Center

New portable computer center and mini LAN (local area network) work center offers flexibility in any operation. The modular characteristics allow the unit to be adaptable to all your equipment requirements such as servers, PCs, printers, keyboards, and monitors. This system features adjustable shelves on 1" increments, quick field assembly without the use of tools, excellent strength (up to 800 lbs. per shelf), durable chrome finish and easy to roll locking 3" polyurethane casters.

MODEL NO.	NO. OF BINS	BIN DIMENSIONS L" x W" x H"	SHIP WGT
Bin Cart with Dividable Grid Containers 21"W x 24"L x 45"H			
BC212434M1	4 DG93060	22-1/2" x 17-1/2" x 6"	58 lbs
Bin Cart with Dividable Grid Containers 21"W x 24"L x 69"H			
BC212469M1	7 DG93060	22-1/2" x 17-1/2" x 6"	68 lbs
BC212469M2	11 DG93030	22-1/2" x 17-1/2" x 3"	84 lbs
Bin Cart with NO Containers (includes slides for 7 bin levels) 21"W x 24"L x 69"H			
BC212469M	--	--	50 lbs
One Pair - 24" Wire Bin Slides			
WR-S24W	--	--	3 lbs



WRC5-63-2436-93060



Order this exact unit M2430CLAN

- Unit consists of:
- 4 - 34" posts
 - 3 - 24" x 30" wire shelves
 - 1 - keyboard tray
 - 1 - document holder basket
 - 4 - 3" poly stem casters



M2430CLAN

HEALTHCARE & MEDICAL



WRC9-63-2448-105

Catheter Cart - Complete Package

Uniquely designed, the catheter bin cart replaces the wire basket concept with color coded bins allowing for quicker identification. The combination of modular wire and plastic bins minimizes shrinkage and reduces unit cost. Bins are molded from high density polypropylene and are available in Blue, Green, Ivory, Red, Yellow, Black and Clear. Cart finish: Chrome

MODEL NO.	BIN DIMENSIONS L" x W" x H"	SHIP WGT
24" x 48" x 69" Wire Catheter Cart with 9 Wire Shelves Complete with 80 QSB105 Bins		
WRC9-63-2448-105	23-5/8" x 4-1/8" x 4"	246 lbs

**COMPLETE
PACKAGE
with bins!**

**LOWEST
PRICE
GUARANTEED!**



Catheter Hold and Store Cart

The catheter hold and store cart allows separation and easy accessibility to prepacked catheters. Ideal for central or OR supply centers, this style cart is modular in design. Includes 32 catheter hooks. Finish: Chrome

MODEL NO.	DIMENSIONS W" x L" x H"	SHIP WGT
Catheter Hold & Store Cart Includes 32 Catheter Hooks		
WRC-BC2448	24" x 48" x 69"	105 lbs

Catheter Hooks

Package includes 6 catheter hooks.
Finish: Chrome



MODEL NO.	DESCRIPTION	CTN WGT
Catheter Hooks - 6 Pack		
WR-CH	6 Catheter Hooks	2 lbs



WRC-BC2448

Shown with Dividable Grid Containers
(Sold separately on page 70)



WRCSL5-63-1836-104

**Dividers,
Bin Cups and
Clear label holders
available on
page 41**

Fastest
Shipping
IN THE INDUSTRY

**LOWEST
PRICE
GUARANTEED!**



WRCSL5-63-1836EP

Slanted Shelf Suture Cart - Open or Enclosed - Complete Packages

Units are designed for quick and easy accessibility for prepacked items such as sutures. The wire end panel maintains product while the slanted shelf allows for gravity feed. Available with or without side enclosures. Bins available in Blue, Green, Ivory, Red, Yellow, Black and Clear. Cart finish: Chrome

OPEN		ENCLOSED	
MODEL NO.	SHIP WGT	MODEL NO.	SHIP WGT
5 Shelf, Slanted Suture Cart 2 Horizontal Shelves and 3 Slanted Shelves			
WRCSL5-63-1836	77 lbs	WRCSL5-63-1836EP	92 lbs
WRCSL5-63-1848	91 lbs	WRCSL5-63-1848EP	106 lbs
WRCSL5-63-2436	92 lbs	WRCSL5-63-2436EP	108 lbs
WRCSL5-63-2448	104 lbs	WRCSL5-63-2448EP	120 lbs

NO. OF BINS	BIN DIMENSIONS L" x W" x H"	OPEN		ENCLOSED	
		MODEL NO.	SHIP WGT	MODEL NO.	SHIP WGT
5 Shelf, Slanted Suture Cart with Bins 2 Horizontal Shelves and 3 Slanted Shelves					
20 QSB104	17-7/8" x 6-5/8" x 4"	WRCSL5-63-1836-104	94 lbs	WRCSL5-63-1836EP-104	103 lbs
28 QSB104	17-7/8" x 6-5/8" x 4"	WRCSL5-63-1848-104	114 lbs	WRCSL5-63-1848EP-104	123 lbs
20 QSB106	23-5/8" x 6-5/8" x 4"	WRCSL5-63-2436-106	115 lbs	WRCSL5-63-2436EP-106	131 lbs
28 QSB106	23-5/8" x 6-5/8" x 4"	WRCSL5-63-2448-106	136 lbs	WRCSL5-63-2448EP-106	152 lbs

COMPLETE PACKAGES with bins!

Slanted Shelf Cart with Bin Holders Combo Cart - Complete Packages

A systems cart that offers hanging bins, slanted bins and bins on a flat surface all in one unit. Cart offer multiple applications the ability to store prepacked items such as sutures or sloped storage for dispensing small parts. This combination creates a highly customized exchange and storage system. Bins available in Blue, Green, Ivory, Red, Yellow, Black and Clear. Cart finish: Chrome

MODEL NO.	NO. OF SHELVES	NO. OF BINS	BIN DIMENSIONS L" x W" x H"	SHIP WGT
18" x 36" x 80" Slanted Wire Shelf Cart with Bin Holders and Bins				
WRCSL5-74-1836-104220	5	20 QSB104 24 QUS220	17-7/8" x 6-5/8" x 4" 7-3/8" x 4-1/8" x 3"	105 lbs
WRCSL5-74-1836-104230	5	20 QSB104 18 QUS230	17-7/8" x 6-5/8" x 4" 10-7/8" x 5-1/2" x 5"	112 lbs
18" x 48" x 80" Slanted Wire Shelf Cart with Bin Holders and Bins				
WRCSL5-74-1848-104220	5	24 QSB104 30 QUS220	17-7/8" x 6-5/8" x 4" 7-3/8" x 4-1/8" x 3"	128 lbs



WRCSL5-74-1836-104230

HEALTHCARE & MEDICAL

Stationary and Mobile Wire Garment Racks

Ideal storage rack for hanging any type of coat or garment.
Includes handy bottom shelf for additional storage.

Finish: Chrome

Each unit consists of:

- 4 - 63" posts
- 2 - wire shelves
- 1 - hang bar

Mobile Unit also includes:

- 4 - 5" swivel poly stem casters, 2 with brakes
- 4 - donut bumpers

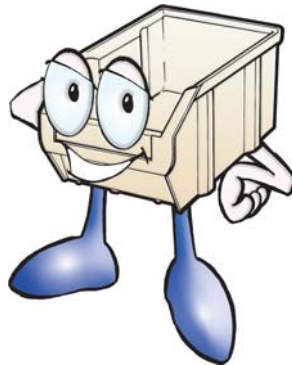

**HANG
IN THERE
BUDDY!**



WRCGR-63-2436

MODEL NO.	NO. OF SHELVES	DIMENSIONS W" x L" x H"	SHIP WGT
Stationary Wire Garment Racks			
WRGR-63-2436	2	24" x 36" x 63"	45 lbs
WRGR-63-2448	2	24" x 48" x 63"	52 lbs
WRGR-63-2460	2	24" x 60" x 63"	63 lbs
Mobile Wire Garment Racks			
WRCGR-63-2436	2	24" x 36" x 69"	59 lbs
WRCGR-63-2448	2	24" x 48" x 69"	66 lbs
WRCGR-63-2460	2	24" x 60" x 69"	77 lbs



WRCPL-63-2460



**LOWEST
PRICE
GUARANTEED!**

Patient Apparel Cart

Ideal for patient care situations where the distribution and holding of apparel is required. The horizontal bar accommodates hangers and the shelves are divided into separate visible compartments. Finish: Chrome

Each unit consists of:

- 4 - 63" posts
- 2 - 54" posts
- 2 - 24" x 60" wire shelves
- 3 - 24" x 36" wire shelves
- 8 - 24" dividers
- 2 - 61" rods & tabs kits
- 1 - 24" hang bar
- 4 - 5" swivel poly stem casters, 2 with brakes
- 4 - donut bumpers

MODEL NO.	NO. OF SHELVES	DIMENSIONS L" x W" x H"	SHIP WGT
WRCPL-63-2460	5	24" x 60" x 69"	146 lbs



18-M-HAMP
20"W x 18"L x 38"H



Hamper

Single bag hamper offers foot activated ABS heavy-duty lid for quick accessibility. Double ring bag holder allows for quick bag insertion and bag lock. Four 3" casters (2 with brake) allows for easy mobility. Finish: Chrome

MODEL NO.	DIMENSIONS W" x L" x H"	SHIP WGT
18-M-HAMP	20" x 18" x 38"	21 lbs

Fastest
Shipping
IN THE INDUSTRY

**LOWEST
PRICE
GUARANTEED!**

COMPLETE PACKAGE with bins!

Bin Transport Cart

The combination of bins and modular shelving creates a highly efficient method of visually identifying and transporting multiple items. The large capacity bins allow for color coding and the rotation of inventories. This multi-tasked unit is excellent for a wide variety of applications and transport solutions. Bins are available in Blue, Red, Yellow and Clear. Cart finish: Chrome

Each unit consists of:

- 4 - 63" posts
- 2 - 54" posts
- 2 - 24" x 60" wire shelves
- 3 - 24" x 36" wire shelves
- 4 - 5" swivel poly stem casters, 2 with brakes
- 4 - donut bumpers
- 4 - QUS955 (23-7/8" x 18-1/4" x 12")

MODEL NO.	DIMENSIONS W" x L" x H"	NO. OF BINS	SHIP WGT
WRCPL-63-2460-955	24" x 60" x 69"	4 QUS955	165 lbs



STAINLESS STEEL



WRSC3-42-2436FS

Open Surgical Case Carts

Corrosion-free surgical case cart transports and delivers surgical instrumentation packs from the OR supply center to the operating room.
Finish: 304 Stainless Steel

Each unit consists of:

- 4 - 42" stainless steel posts
- 2 - stainless steel wire shelves
- 1 - stainless steel solid shelf
- 1 - stainless steel 3-sided frame (additional available on page 98)
- 1 - stainless steel push handle
- 4 - 5" swivel, stainless steel poly stem casters, 2 with brakes (casters come with Zerk Grease Fittings)
- 4 - donut bumpers

MODEL NO.	DIMENSIONS W" x L" x H"	NO. OF SHELVES	SHIP WGT
WRSC3-42-2436FS	24" x 36" x 48"	3	77 lbs
WRSC3-42-2448FS	24" x 48" x 48"	3	88 lbs
WRSC3-42-2460FS	24" x 60" x 48"	3	106 lbs

Stainless Steel Carts

Ideal for transport and storage and continuous transporting over even floor surfaces. Carts are manufactured of 22 gauge stainless steel shelves and 20 gauge stainless steel legs. Sound deadening panels under shelves limit vibrations and noise. Bumpers on legs and handles protect walls and furniture. To clean: wipe down or steam clean.

MODEL NO.	NO. OF SHELVES	DIMENSIONS L" x W" x H"	SHIP WGT
300 lb. Load Capacity Cart			
SSC2716-32-3L	3	16-1/4" x 27-1/2" x 32-1/8"	29 lbs
SSC3018-33-3L	3	18-3/8" x 30-3/4" x 33"	33 lbs
500 lb. Load Capacity Cart			
SSC2716-32-3M	3	16-3/4" x 27-5/8" x 32"	39 lbs
SSC3119-32-3M	3	19" x 31" x 32"	42 lbs
SSC3922-37-3M	3	22-3/8" x 39-1/4" x 37-1/4"	68 lbs



SSC2716-32-3L

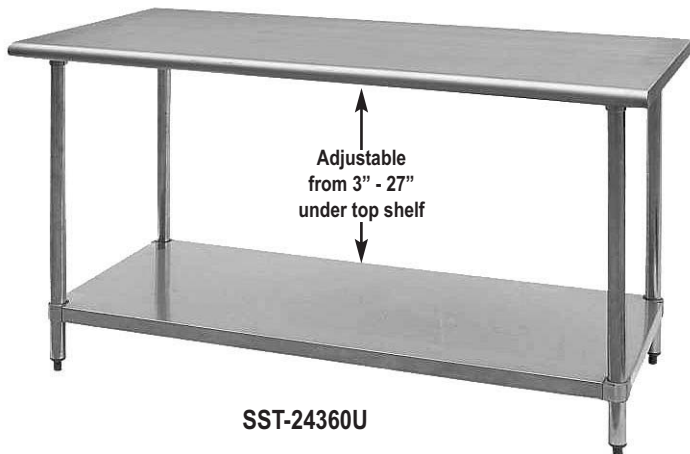

SST-24360U

Stainless Steel Work Table with Adjustable Underself

Heavy-duty 304 stainless steel processing tables are ideal for pack and prep in sterile environments. Units consist of a flat top work surface with hemmed edges and the lower flat bottom shelf is adjustable from 3" to 27" high. Tables are NSF approved. The support legs are 1-5/8" diameter with a leveling foot which can be converted to a mobile unit with a 3" conductive caster kit, all swivel, 2 with brake. (Sold separately) Finish: 304 Stainless Steel

MODEL NO.	DIMENSIONS W" x L" x H"	NO. OF SHELVES	SHIP WGT
Stationary Instrument Table with Shelf			
SST-2436U	24" x 36" x 34"	1	50 lbs
SST-2448U	24" x 48" x 34"	1	60 lbs
SST-2460U	24" x 60" x 34"	1	70 lbs
SST-2472U	24" x 72" x 34"	1	80 lbs
Mobile Kit			
SST-MOB	4 Swivel Casters, 2 with Brakes		4 lbs

WIRE SHELVING ACCESSORIES



WR-00

(Shown with and without brake)
Sold as a set of 4 casters, 2 with brake



WR-00H

(Shown with and without brake)
Sold as a set of 4 casters, 2 with brake



WR-00HS

(Shown with and without brake)
Sold as a set of 4 casters, 2 with brake



WR-3

Sold as a set of 4 casters, all with brake



WR-RG

Requires Tie Bar
See chart below



WR-PS

MODEL NO.	DESCRIPTION	LOAD CAP PER CASTER	SHIP WGT
Stem Casters			
WR-00	Four Swivel 5" x 1-1/4" Rubber Casters, 2 with brake	200 lbs	12 lbs
WR-00H	Four Swivel 5" x 1-1/4" Polyurethane Casters, 2 with brake	300 lbs	10 lbs
WR-00HS	Four Swivel 5" x 1-1/4" Polyurethane Stainless Steel Casters with Zerk Grease Fittings, 2 with brake	300 lbs	12 lbs
WR-00CO	Four Swivel ESD/Conductive 5" x 1-1/4" Casters, 2 with brake	300 lbs	12 lbs
WR-3	Four Swivel 3" Polyurethane, all with brake	200 lbs	8 lbs
WR-RG*	One Rigid 5" x 1-1/4" Polyurethane Caster	300 lbs	3 lbs
WR-PS	One Swivel 8" x 2-1/2" Pneumatic Caster	325 lbs	4 lbs
Plate Casters			
PT-PS	One Swivel 5" x 1-1/4" Polyurethane Caster	300 lbs	3 lbs
PT-PR	One Rigid 5" x 1-1/4" Polyurethane Caster	300 lbs	3 lbs
PT-PSB	One Swivel 5" x 1-1/4" Polyurethane Caster with brake	300 lbs	3 lbs
PT-NS	One Swivel 8" x 2-1/2" Pneumatic	325 lbs	4 lbs
PT-NR	One Rigid 8" x 2-1/2" Pneumatic	325 lbs	4 lbs

* Requires Tie Bar for rigid alignment



PT-PS



PT-PR



PT-PSB



PT-NS



PT-NR

Tie Bar

Is required with rigid casters to ensure rigid alignment. Tie bar length should match up to shelf depth. (Rigid casters sold separately) Finish: Chrome



MODEL NO.	DESCRIPTION	SHIP WGT
18TB	One 18" Tie Bar which fits 2 casters	2 lbs
21TB	One 21" Tie Bar which fits 2 casters	2 lbs
24TB	One 24" Tie Bar which fits 2 casters	2 lbs

Donut Bumper

Non-marking, 3" diameter rubber bumper used to protect walls and help cushion impact.



MODEL NO.	DESCRIPTION	SHIP WGT
DB	One 3" Diameter Donut Bumper	1 lbs

Push Handle

Comfortable grip design. Three widths available enabling easy movement of any mobile unit. Finish: Chrome



MODEL NO.	DESCRIPTION	SHIP WGT
PH18	One 18" Push Handle	2 lbs
PH21	One 21" Push Handle	3 lbs
PH24	One 24" Push Handle	3 lbs

U-Handle

Build your own special size utility cart with three different width choices: 18", 21" or 24". Overall height 32", not including casters. Finish: Chrome



MODEL NO.	DESCRIPTION	SHIP WGT
UH18	18" U-Handle	2 lbs
UH21	21" U-Handle	3 lbs
UH24	24" U-Handle	3 lbs

Modular Dolly Frames

Dolly Frames allow standard shelving units to be converted to heavy-duty transport trucks. Frames are fabricated from heavy gauge steel with a chrome finish. Bumpers are attached to each corner to protect walls and help cushion impact. (Plate casters sold separately)

MODEL NO.	DIMENSIONS W" x L"	SHIP WGT
DB1836C	18" x 36"	10 lbs
DB1848C	18" x 48"	12 lbs
DB1860C	18" x 60"	14 lbs
DB2436C	24" x 36"	13 lbs
DB2448C	24" x 48"	15 lbs
DB2460C	24" x 60"	18 lbs



LOWEST PRICE GUARANTEED!



WIRE SHELVING ACCESSORIES

MODEL NO.	DESCRIPTION	SHIP WGT
Side Ledges		
SL12	12" Side Ledge	1 lb
SL14	14" Side Ledge	1 lb
SL18	18" Side Ledge	1 lb
SL21	21" Side Ledge	2 lbs
SL24	24" Side Ledge	2 lbs
SL30	30" Side/Back Ledge	2 lbs
Back Ledges		
BL36	36" Back/Side Ledge	3 lbs
BL42	42" Back Ledge	3 lbs
BL48	48" Back Ledge	3 lbs
BL54	54" Back Ledge	4 lbs
BL60	60" Back Ledge	5 lbs
BL72	72" Back Ledge	6 lbs

Side and Back Ledges

Ledges are 4"H and act as a perimeter to retain shelf items and prevent anything from falling off. Finish: Chrome

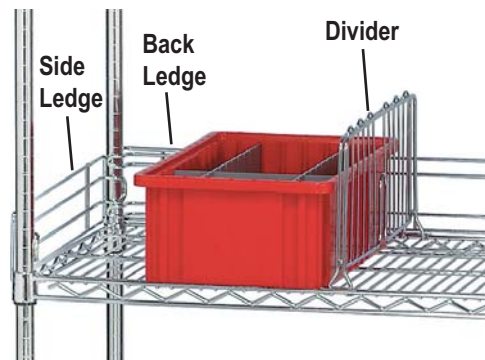

Dividers

Dividers are 8"H and are available in 7 depths to be used with all shelves. Dividers come 2 per package. Finish: Chrome

MODEL NO.	DESCRIPTION	SHIP WGT
Dividers		
DIV12	One 12" Divider	2 lbs
DIV14	One 14" Divider	2 lbs
DIV18	One 18" Divider	2 lbs
DIV21	One 21" Divider	3 lbs
DIV24	One 24" Divider	3 lbs
DIV30	One 30" Divider	4 lbs
DIV36	One 36" Divider	4 lbs

Bin Rail Holder

Creates a more functional work area with the bin rail which allows you to adapt bins to your shelving unit.

MODEL NO.	DESCRIPTION	SHIP WGT
36BH	One 36" Bin Holder	5 lbs
48BH	One 48" Bin Holder	7 lbs
60BH	One 60" Bin Holder	9 lbs

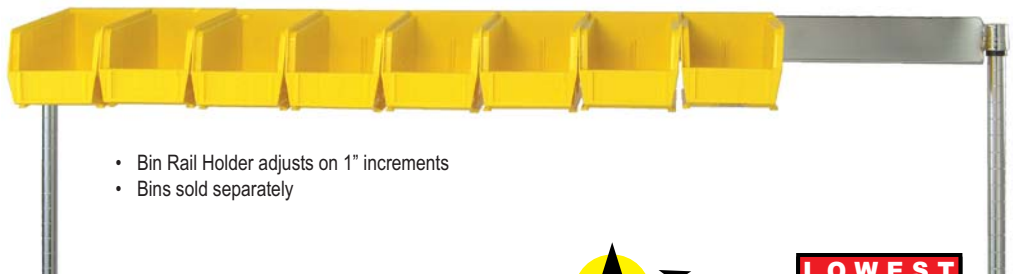

- Bin Rail Holder adjusts on 1" increments
- Bins sold separately

Single and Double Drawer Slides

Compliment any system with specialized areas for storage which allow bins and trays to be suspended between shelves. Single bin slide mounts 18" and 21" shelves. Double bin slide adapts to 24" shelves only. **Bins sold separately.**



MODEL NO.	DESCRIPTION	SHIP WGT
DS18-24	Single Bin Design	2 lbs
DDS-24	Double Bin Design	4 lbs

Choose from one bin/tray design or two bin/tray design



Modular Enclosure Panels

Are easily adaptable to standard shelving units to create a secured storage area.

- Panels are fabricated from 6 gauge wire on 3" x 3" squares
- Modular enclosure panels work with three shelf depths: 18", 21" and 24" and two heights: 63" and 74"
- One modular enclosure panel is needed for each side and two panels are needed for the back

MODEL NO.	DESCRIPTION	SHIP WGT
EP166	One 16" x 62" Enclosure Panel	6 lbs
EP196	One 19" x 62" Enclosure Panel	7 lbs
EP226	One 22" x 62" Enclosure Panel	8 lbs
EP167	One 16" x 73" Enclosure Panel	7 lbs
EP197	One 19" x 73" Enclosure Panel	8 lbs
EP227	One 22" x 73" Enclosure Panel	9 lbs



Mobile cart shown with 4 enclosure panels

Shelf Inlay Mat

An economical solution to convert a wire shelf to a solid surface preventing items from falling through. White shelf inlay mat is easily removable for cleaning.

MODEL NO.	DESCRIPTION	SHIP WGT
1836SM	One 18" x 36" Inlay Mat	1 lb
1848SM	One 18" x 48" Inlay Mat	2 lbs
1860SM	One 18" x 60" Inlay Mat	2 lbs
1872SM	One 18" x 72" Inlay Mat	2 lbs
2436SM	One 24" x 36" Inlay Mat	2 lbs
2448SM	One 24" x 48" Inlay Mat	2 lbs
2460SM	One 24" x 60" Inlay Mat	2 lbs
2472SM	One 24" x 72" Inlay Mat	3 lbs

Label Holders

Are an excellent method for identifying product. Affix directly to truss on any size shelf. Four lengths to choose from.



MODEL NO.	DESCRIPTION	SHIP WGT
LH3B	3" Black Label Holder	1 lb
LH3C	3" Clear Label Holder	1 lb
LH12C	12" Clear Label Holder	1 lb
LH24C	24" Clear Label Holder	1 lb

WIRE SHELVING ACCESSORIES

CONDUCTIVE APPLICATIONS



Aluminum Split Sleeve

Model No.: ESD-SS

Aluminum Split Sleeves required when grounding standard wire shelving in conductive application.

Drag Chain

Model No.: ESD-DC

Drag chain is mounted to bottom of shelf and is used to ground standard wire shelving units. Used in conjunction with aluminum split sleeves.



Post Clamp

Joins multiple units of shelving.

MODEL NO.	DESCRIPTION	SHIP WGT
PCL1	1/2" Post Clamp	4 lbs
PCL2	3-1/3" Post Clamp	5 lbs



Model No.: S-Hook

For continuous runs of shelving. Two hooks should be placed per shelf where two posts are not utilized. Sold as an 8 pack.

Finishes: Chrome, Proform & Stainless Steel



Foot Plate

Model No.: FP

Triangular plate allows additional surface to disperse weight.



Non-Marring Floor Glides

Model No.: FG

Serves as protection to prevent marring of floors. Sold as a 4 pack.



Split Sleeve

Model No.: WR-SS

Sold as a pack of 4 pairs.



Shelf Collar Plug

Model No.: WR-SP

Sold as a pack of 4 pieces.



Collar Hooks

Used to secure baskets to posts or as a hook for cables. Sold in packs of four.

MODEL NO.	DESCRIPTION	SHIP WGT
SCH1-5	1-1/2" Hook	1 lb
SCH1	1/2" Hook	1 lb

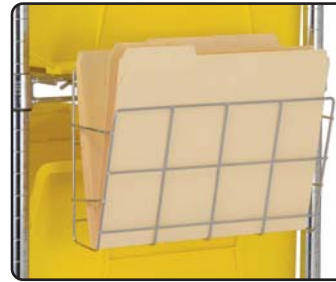

Document Holder

Model No.: DH8

Provides an effective way to secure documents. Measures 12-3/8" x 2" x 8-5/8"H



Utility Basket

Model No.: UB10

An additional storage or display area outside the perimeter of the shelf. Measures 11-1/4" x 18-7/8" x 7-5/8"H



Post Wall Mount Bracket

Model No.: WR-WMB

Mounts post to wall securely. 2" clearance required.

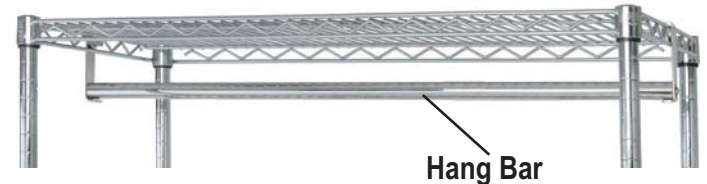

Hang Bar

LOWEST PRICE GUARANTEED!

MODEL NO.	DESCRIPTION	SHIP WGT
GR24	One 24" Hang Bar	2 lbs
GR36	One 36" Hang Bar	3 lbs
GR48	One 48" Hang Bar	4 lbs
GR60	One 60" Hang Bar	5 lbs



Keyboard Shelf

Model No.: KEYBD

Mounts under any size wire shelf and accepts keyboards up to 21"W x 11"D. Has a 6" height adjustment. Measures 25-1/4"W x 15"D x 4-1/4"H

HIGH DENSITY SLIDING TRACK SYSTEM

Top Track Available Fall 2011



Units slide back and forth with ease

Maximize Your Storage Space!

High Density Sliding Track System

High Density Sliding Track System offers a unique way to maximize and efficiently move wire shelving systems. The patented design allows for quick and easy installation. Bearings in the skate are located under each post for a load capacity of 1,500 lbs. per shelving unit. The V-groove floor track allows the shelving unit to slide back and forth with ease. Layout assistance is available.

FEATURES AND BENEFITS:

- Cuts construction costs
- Low shipping cost
- NSF approved
- Uses industrial bearings
- Corrosion free construction
- Easy to roll construction
- Fast installation
- Utilizes the structure of existing shelving
- Complies with ADA regulations
- 1,500 lb. load capacity per unit
- Can increase storage areas up to 150%



STEP BY STEP ORDERING INSTRUCTIONS:

(Note: Shelves and posts to be purchased separately on pages 88-89)

Step 1 - Select desired length (in inches) of track. Use Model No.: QVTRK to order track. (Note that single units require two tracks and double units will require three tracks)

Step 2 - Select corresponding skate size from the chart, which will be the same as the depth of shelving unit to be utilized. Two skates required per single unit and three skates required per double unit. (Note, post height should not exceed a 4 to 1 ratio of skate size)

Step 3 - Purchase one End Stop Kit (Model No.: QUESTP) per track length.

For each double unit being used, a Wing Kit (Model No.: WK) is required.

MODEL NO.	DESCRIPTION	SHIP WGT
Sliding Track Skates		
HD18	One 18" Skate	4 lbs
HD21	One 21" Skate	5 lbs
HD24	One 24" Skate	6 lbs
HD30	One 30" Skate	7 lbs
HD36	One 36" Skate	8 lbs
Additional Components		
QUESTP	End Stop Kit	1 lb
QVTRK	V-Track (Sold per inch)	1 lb
WK	Wing Kit	2 lbs

Wing Kit Model No.: WK

Includes four 1/4" thick plates & hardware and allows for the joining of 2 units side by side, sharing one track.

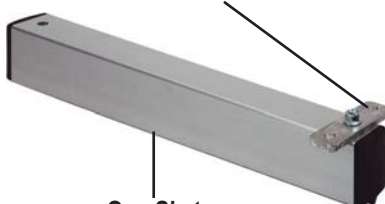

One Skate
Model No.: HD18 - HD36

V-Groove Track Model No.: QVTRK (Sold by the inch)



End Stop Kit Model No.: QUESTP

Includes 2 ends and 1 drill bit. Serves the dual purpose of stopping a skate and is the anchor for the track. One kit is required per track.

HIGH DENSITY SLIDING TRACK PACKAGES

SINGLE UNIT TRACK SYSTEM
(Top View)

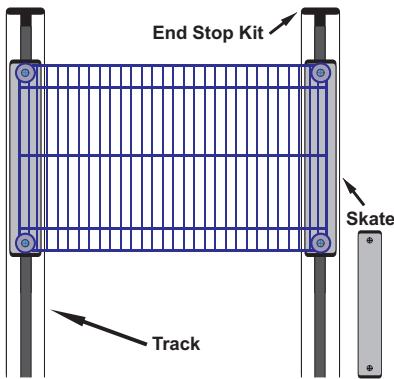

ORDERING INSTRUCTIONS:

- Step 1** - Select desired length of track and if you require:
- Single Unit track (use charts on left)
 - Double Unit track (use charts on right)
- Step 2** - Select corresponding skate size from single or double unit charts below. Skate size should match the depth of shelving unit being utilized.
- Step 3** - Using the chart on the bottom of this page, determine how many shelving units will fit on your track.
- Step 4** - Preconfigured 4-Shelf wire units are available on pages 90-93. Additional intermediate shelves are available on page 88.

DOUBLE UNIT TRACK SYSTEM
(Top View)

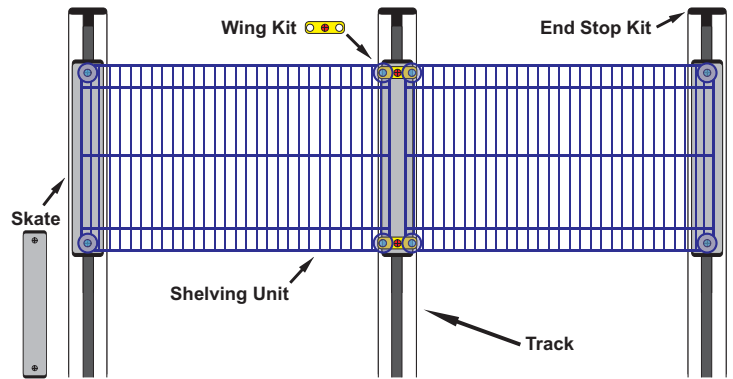

Single Unit Floor Track Assembly Kit

Assembly kit consists of a pair of aluminum tracks with end stop kits. Hardware and assembly instructions included. (Note: custom lengths may be purchased, see page 126)



Double Unit Floor Track Assembly Kit

Each assembly kit consists of three aluminum tracks with end stop kits. Hardware and assembly instructions included. (Note: custom lengths may be purchased, see page 126)



MODEL NO.	TRACK L' (FT)	TRACK L" (IN)	SHIP WGT
Single Unit Floor Track Assembly Kit Includes 2 Tracks of Specified Length with End Stop Kits			
QVTRK-2-72EST	6'	72"	14 lbs
QVTRK-2-84EST	7'	84"	16 lbs
QVTRK-2-96EST	8'	96"	18 lbs
QVTRK-2-108EST	9'	108"	20 lbs
QVTRK-2-120EST	10'	120"	22 lbs
QVTRK-2-132EST	11'	132"	24 lbs
QVTRK-2-144EST	12'	144"	26 lbs
QVTRK-2-156EST	13'	156"	28 lbs
QVTRK-2-168EST	14'	168"	30 lbs
QVTRK-2-180EST	15'	180"	32 lbs
QVTRK-2-192EST	16'	192"	34 lbs
QVTRK-2-204EST	17'	204"	36 lbs
QVTRK-2-216EST	18'	216"	38 lbs
QVTRK-2-228EST	19'	228"	40 lbs
QVTRK-2-240EST	20'	240"	42 lbs

MODEL NO.	TRACK L' (FT)	TRACK L" (IN)	SHIP WGT
Double Unit Floor Track Assembly Kit Includes 3 Tracks of Specified Length with End Stop Kits			
QVTRK-3-72EST	6'	72"	21 lbs
QVTRK-3-84EST	7'	84"	24 lbs
QVTRK-3-96EST	8'	96"	27 lbs
QVTRK-3-108EST	9'	108"	30 lbs
QVTRK-3-120EST	10'	120"	33 lbs
QVTRK-3-132EST	11'	132"	36 lbs
QVTRK-3-144EST	12'	144"	39 lbs
QVTRK-3-156EST	13'	156"	42 lbs
QVTRK-3-168EST	14'	168"	45 lbs
QVTRK-3-180EST	15'	180"	48 lbs
QVTRK-3-192EST	16'	192"	51 lbs
QVTRK-3-204EST	17'	204"	54 lbs
QVTRK-3-216EST	18'	216"	57 lbs
QVTRK-3-228EST	19'	228"	60 lbs
QVTRK-3-240EST	20'	240"	63 lbs

Single Unit Skate Assembly Kit

Each kit includes two skates and all appropriate hardware. One kit is required for each single mobile unit. (Shelves and posts sold separately on pages 88 and 89)

MODEL NO.	DESCRIPTION	SHIP WGT
Single Unit Skate Assembly Kit		
HD18-2	Two 18" Skates	8 lbs
HD21-2	Two 21" Skates	10 lbs
HD24-2	Two 24" Skates	12 lbs
HD30-2	Two 30" Skates	14 lbs
HD36-2	Two 36" Skates	16 lbs

Double Unit Skate Assembly Kit

Each kit includes three skates and all appropriate hardware. One kit is required for each double mobile unit. (Shelves and posts sold separately on pages 88 and 89)

MODEL NO.	DESCRIPTION	SHIP WGT
Double Unit Skate Assembly Kit		
HD18-3	Three 18" Skates + Wing Kit	15 lbs
HD21-3	Three 21" Skates + Wing Kit	18 lbs
HD24-3	Three 24" Skates + Wing Kit	21 lbs
HD30-3	Three 30" Skates + Wing Kit	24 lbs
HD36-3	Three 36" Skates + Wing Kit	27 lbs

QUANTITY OF SHELVING UNITS BY WIDTH TO FIT ON LENGTH OF TRACK*

	6'	7'	8'	9'	10'	11'	12'	13'	14'	15'	16'	17'	18'	19'	20'
18"	2	2	3	4	4	5	6	6	7	8	8	9	10	10	11
21"	1	2	2	3	4	4	5	5	6	6	7	8	8	9	9
24"	1	2	2	3	3	4	4	5	5	6	6	7	7	8	8
30"	1	1	2	2	2	3	3	4	4	4	5	5	6	6	6
36"	1	1	1	2	2	2	3	3	3	4	4	4	5	5	5

* Using a minimum 36" aisle space. Note, post height should not exceed the skate length by a 4 to 1 ration (example 18" skate should not exceed a 74" post)

LAYOUT & DESIGN SERVICES

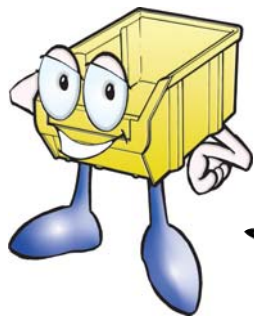
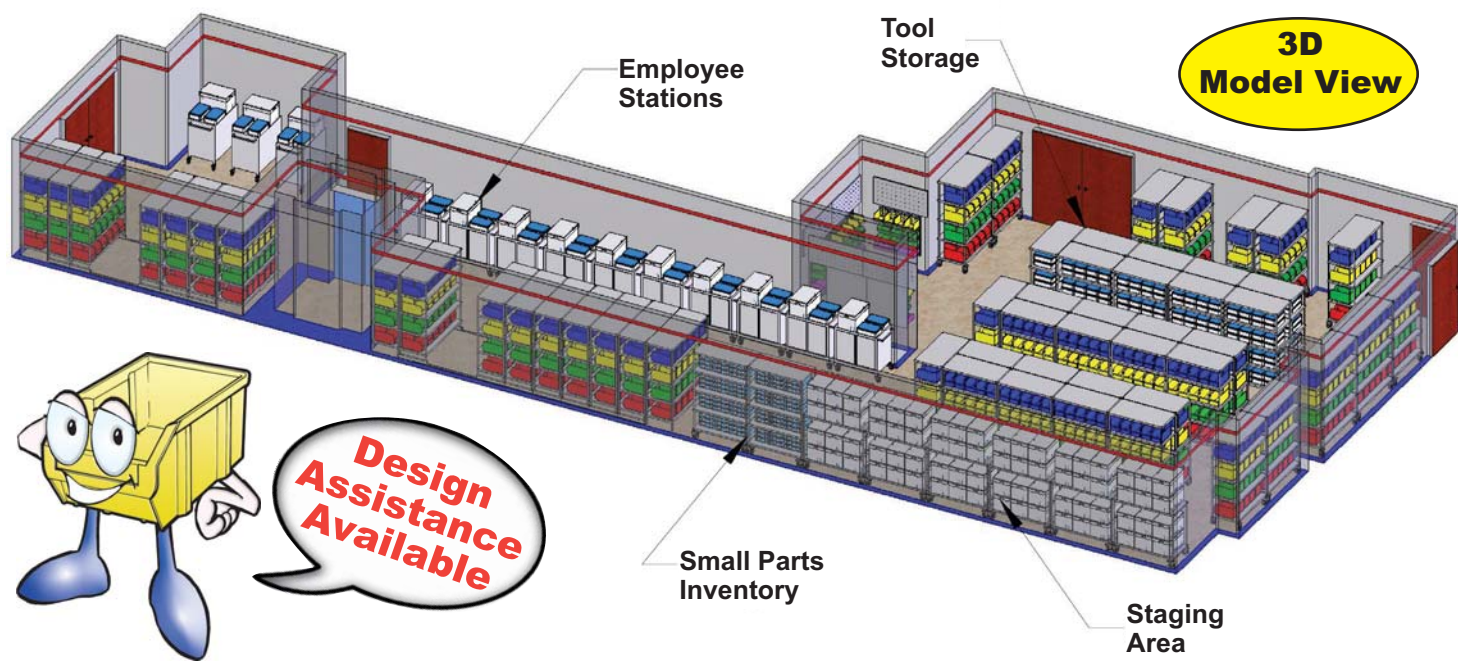

Design Assistance Available

Quantum Layout & Design Service

Design assistance is available for all your major projects from room layouts to shelving or cart design. We'll create and develop an integrated system around your requirements. Layouts can be created to accommodate your space with the appropriate product mix consisting of:

- Wire Shelving
- Stationary Shelving
- Bins
- Wall Systems
- Baskets
- Containers
- Hi-Density Mobile Track Systems

Quantum Storage offers the most complete package of storage products to satisfy all your requirements. Let us review your next project to maximize your storage space.

TO ACHIEVE THE BEST RESULTS, PLEASE PROVIDE THE FOLLOWING INFORMATION:

- Room dimensions with door locations and door clearances, column locations (L x W) and ceiling height
- For shelving units, provide the number of shelf tiers, post height and indicate stationary or mobile
- If bins are required, indicate the appropriate size and whether they are to be used on shelving or wall mounted louvered panels

- Industry Exclusive 3D Modeling
- Blueprint & AutoCAD Compatible
- Space Utilization & Maximization
- Plan-o-grams

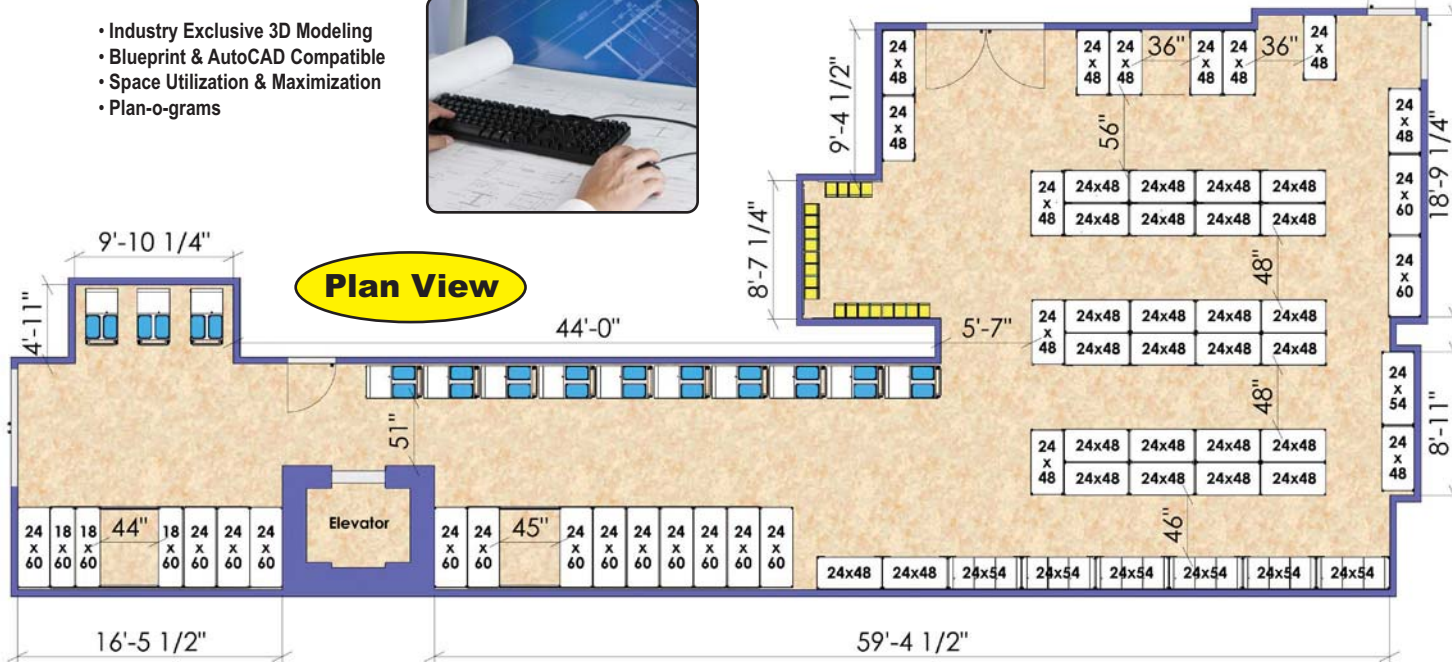
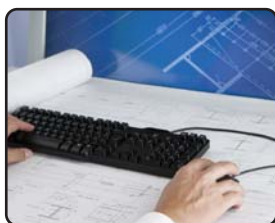

QUICK FIND MODEL NUMBER INDEX

MODEL NO.	PG.	1836SS - 1860SS..... 89	36BH - 60BH..... 124	CL1239-601..... 50	DH8..... 125	M2036BD - M2048BD..... 100
1017HBC..... 102,103	1839-000..... 42,50	3636C - 3672C..... 88	CL1275-000..... 50	DIV12 - DIV36..... 124	M2430CLAN..... 117	
1035HBC..... 102,103	1839-100..... 42	3636E - 3672E..... 88	CL1275-401..... 50	DIV-12-3 - DIV-30-16..... 85	M2436-69SEC - M2460-69SEC..... 113	
1224C - 1272C..... 88	1839-103CL..... 8	39-1236-4 - 39-1842-6..... 86	CL1275-501..... 50	DIV201 - DIV204..... 53,64	M2436C46E - M2460C46E..... 110	
1236E - 1272E..... 88	1839-104..... 42	4X3HBD - 4X15HBD..... 103	CL1275-601..... 50	DIV303 - DIV304..... 58	M2436C46RE - M2460C46RE..... 110	
1239-000..... 42,50	1839-104CL..... 8	4B2212DPP..... 69,99	CL1275-701..... 50	DIV400..... 59	M2436C47RE - M2460C47RE..... 110	
1239-100..... 42	1839-108..... 42	52RT - 84RT..... 111	CL1275-801..... 50	DIV401 - DIV801..... 49	MD1836C46RE-MD2460C46RE..... 110	
1239-100CL..... 8	1839-108CL..... 8	75-1236-4 - 75-1842-8..... 86	CL1839-000..... 50	DL91035 - DL93120..... 70	MD1836C47RE-MD2460C47RE..... 110	
1239-101..... 42	1839-110..... 42	AD18G-39-1236-4..... 80	CL1839-602..... 50	DL91035CO - DL93120CO..... 57	MD1836CG46RE..... 111	
1239-101CL..... 8	1839-110CL..... 8	AD18G-75-1236-5..... 111	CL1839-604..... 50	DLY-2415..... 67	MD2460CG46RE..... 111	
1239-102..... 42	1839-120..... 47	AD18G-87-1236-5..... 81	CL1875-602..... 50	DLY-3018..... 67	MD2460CG47RE..... 111	
1239-102CL..... 8	1839-204..... 47	AD18G-87-1236-5..... 81	CL1875-604..... 50	DMS531 - DMS543..... 33	MD2436-70SEC - MD2460-70SEC..... 113	
1239-107..... 42	1839-208..... 47	AD18G-99-1236-5..... 81	CL1875-606..... 50	DNB-12..... 84	MESH-240..... 37	
1239-107CL..... 8	1839-210..... 47	AD18G-99-1236-5..... 81	CL1875-624..... 50	DS18-24..... 124	MESH-240250..... 37	
1239-109..... 42	1839-602..... 50	AD20G-39-1236-4..... 80	CL2439-603..... 50	DS91035 - DS93120..... 70	MESH-250..... 37	
1239-109CL..... 8	1839-604..... 50	AD20G-39-3048-6..... 80	CL2475-603..... 50	DS91035CO - DS93120CO..... 57	MSU-16-MIX..... 34	
1239-201..... 47	1839-624..... 42,50	AD20G-75-1236-5..... 81	CL18G-39-1236-4..... 82	DSB101 - DSB116..... 41	MSU-531..... 34	
1239-202..... 47	1875-103..... 42	AD20G-75-1236-5..... 81	CL18G-39-3048-6..... 82	DSB101CO - DSB116CO..... 57	MSU-532..... 34	
1239-207..... 47	1875-103CL..... 8	AD20G-87-1236-5..... 81	CL18G-75-1236-5..... 83	DSB201 - DSB216..... 46	MSU-533..... 34	
1239-209..... 47	1875-104..... 42	AD20G-87-1236-5..... 81	CL18G-75-3048-7..... 83	DUS200 - DUS270..... 13	MSU-543..... 34	
1239-401..... 50	1875-104CL..... 8	AD20G-99-1236-5..... 81	CL18G-87-1236-5..... 83	DUS205CO - DUS270CO..... 55	MTT-1842-543..... 76	
1239-601..... 50	1875-108..... 42	AD20G-99-3048-7..... 81	CL20G-39-1236-4..... 82	DUS950 - DUS955..... 22	MTT-1860-543..... 76	
1275-000..... 42,50	1875-108CL..... 8	ADCL18G-39-1236-4..... 84	CL20G-39-3048-6..... 82	DUS970 - DUS976..... 25	MTT-1878-543..... 76	
1275-100..... 42	1875-110CL..... 8	ADCL18G-75-1236-5..... 85	CL20G-75-1236-5..... 83	DUS993 - DUS997..... 25	MTT-3048-743..... 76	
1275-101..... 42	1875-203..... 47	ADCL18G-75-1236-5..... 85	CL20G-75-3048-7..... 83	DWB14 - DWB24..... 106	MTT-3060-743..... 76	
1275-101CL..... 8	1875-203CL..... 8	ADCL18G-87-3048-7..... 85	CL20G-99-1236-5..... 83	ELH410 - ELH445..... 41,46	MTT-3078-743..... 76	
1275-102..... 42	1875-204..... 47	ADCL18G-87-3048-7..... 85	CL39-1236-4..... 86	EP166 - EP227..... 124	MWR4-2419-9..... 73	
1275-102CL..... 8	1875-208..... 47	ADCL18G-99-1236-5..... 85	CL39-1842-6..... 86	ESD-DC..... 125	MWRS-5-1711-12..... 73	
1275-107..... 42	1875-210..... 47	ADCL18G-99-1236-5..... 85	CL75-1236-4..... 86	ESD-SS..... 125	MWR7-1711-8..... 73	
1275-107CL..... 8	1875-602..... 50	ADCL20G-39-1236-4..... 84	COV91000..... 70	FB-36-1 - FB-48-2..... 85	MWR7-1711-8..... 73	
1275-109..... 42	1875-602CL..... 8	ADCL20G-39-3048-6..... 84	COV91000CL..... 70	FG..... 125	MWR7-5-92035..... 97	
1275-109CL..... 8	1875-604..... 50	ADCL20G-39-3048-6..... 84	COV91000CO..... 57	FP..... 125	MWR7-5-92060..... 97	
1275-201..... 47	1875-606..... 50	ADCL20G-75-1236-5..... 85	COV92000..... 70	G-725..... 61	MWR7-5-92080..... 97	
1275-202..... 47	20G-1236-SHELF..... 47	ADCL20G-75-3048-7..... 85	COV92000CL..... 70	G-725304-28..... 61	MWR7-7-103..... 97	
1275-209..... 47	20G-3048-SHELF..... 78	ADCL20G-75-3048-7..... 85	COV92000CO..... 57	G-725305-36..... 61	MWR7-7-104..... 97	
1275-401..... 50	20G-39-1236-4..... 78	AD54-1236C-AD54-3672C..... 90	COV92000CL..... 70	G-725306-56..... 61	MWR7-7-108..... 97	
1275-501..... 50	20G-75-1236-5..... 79	AD54-1436P-AD54-2472P..... 94	COV92000CO..... 57	G-725309-80..... 61	MWR7-7-110..... 97	
1275-701..... 50	20G-87-1236-5..... 79	AD54-1436P-AD54-2472P..... 94	COV92000CL..... 70	G-725569-56..... 61	MWR7-7-602..... 97	
1424C - 1472C..... 88	20G-99-1236-5..... 79	AD54-1436P-AD54-2472P..... 94	COV92000CO..... 57	GR24 - GR60..... 125	MWR7-7-604..... 97	
1424E - 1472E..... 88	20G-99-3048-7..... 79	AD63-1236C-AD63-3672C..... 91	COV92000CL..... 70	GSP-2448 - GSP-2472..... 108	MWR7-7-606..... 97	
1424P - 1472P..... 88	2026ESD - 2026TR..... 116	AD63-1436P-AD63-2472P..... 94	COV92000CO..... 57	GSP-5HOOK-16..... 108	OP-39 - OP-147..... 80	
1424S - 1472S..... 88	2124C - 2172C..... 88	AD63-1836S-AD63-2472S..... 95	COV93000..... 70	GSP-B12128..... 108	OP-CC..... 84	
1436BC - 204812BC..... 98,100	2124E - 2172E..... 88	AD63-1836S-AD63-2472S..... 95	COV93000CL..... 70	GSP-HOOK6 - GSP-HOOK10..... 108	ORG80032 - ORG80322..... 66	
149DC - 2012DC..... 98,100	2124P - 2172P..... 88	AD63-1836SG-AD63-2460SG..... 96	COV93000CO..... 57	GSP-SB12128 - GSP-SB2215..... 108	P6C - P96C..... 89	
1617HBC..... 102,103	2124S - 2172S..... 88	AD74-1236C-AD74-3672C..... 92	DB..... 123	GSP-WMHD..... 108	P6E - P96E..... 89	
1635HBC..... 102,103	2436-63SEC..... 113	AD74-1436P-AD74-2472P..... 94	DB1836C - DB2460C..... 123	HD18 - HD36..... 126	P6P - P96P..... 89	
18G-1236-SHELF..... 78	2460-63SEC..... 113	AD74-1836SG-AD74-2460SG..... 96	DCB14 - DCB24..... 106	HD18-2 - HD36-2..... 127	P6S - P96S..... 89	
18G-3048-SHELF..... 78	2424C - 2472C..... 88	AD86-1236C-AD86-3672C..... 93	DDC91000CL - DDC93000CL..... 10,70	HD18-3 - HD36-3..... 127	PB-1X1-PH..... 105	
18G-39-3048-6..... 78	2424E - 2472E..... 88	AD86-1436P-AD86-2472P..... 94	DDS-24..... 124	HNS006..... 5,17,105	PB-1X30-SR - PB-8X30-SR..... 105	
18G-75-1236-5..... 79	2424P - 2472P..... 88	AD86-1836S-AD86-2472S..... 95	DG91035..... 70	HNS200 - HNS230..... 17	PB-24X48-2 - PB-24X48-4..... 104	
18G-87-1236-5..... 79	2424S - 2472S..... 88	AD86-1836SG-AD86-2460SG..... 96	DG91035CO..... 57	HNS200CL - HNS230CL..... 5	PB-2-CH - PB-3-CH..... 105	
18G-87-3048-7..... 79	2436EPC - 2460EPC..... 113	AP-39 - AP-75..... 80	DG91050..... 70	IDR201 - IDR204..... 53,64	PB-3-DMU..... 105	
18G-99-1236-5..... 79	2436FSS - 2460FSS..... 98	BC212434M1 - BC212469M2..... 117	DG91050CL..... 57	KEYBD..... 125	PB-3X80-DR - PB-8X80-DR..... 105	
18-M-HAMP..... 121	2436SG - 2460SG..... 89	BC212434M1CL - BC212469M2CL..... 10	DG91050CO..... 57	LBL2X8 - LBL5X8..... 70	PB-5-DCEL - PB-8-DCEL..... 105	
18TB - 24TB..... 123	2439-603..... 23	BL36 - BL72..... 124	DG92035..... 70	LBL2X8CO - LBL5X8CO..... 57	PB-6X12SHELF..... 105	
1824C - 1872C..... 88	2475-20-MIX..... 50	BLH3C - BLH32C..... 100,103	DG92035CL..... 10	LD965 - LD1887..... 52	PB-BINCLIP..... 105	
1824E - 1872E..... 88	2475-603..... 50	BP-39 - BP-147..... 80	DG92060..... 70	LGH700..... 30	PB-C-QUS200..... 105	
1824P - 1872P..... 88	2475-950..... 23	BP-3639 - BP-4899..... 82	DG92060CL..... 10	LH34M - LH24C..... 124	PB-C-QUS210CL..... 105	
1824S - 1872S..... 88	2475-95052..... 23	CAN-34-36BH-230..... 107	DG92060CO..... 57	LID1215 - LID2415..... 67	PB-C-QUS210CL..... 105	
1826ESD - 1826TR..... 116	2475-950952CL..... 6	CAN-34-48BH-230..... 107	DG92080..... 70	LID1711 - LID2516-8..... 71	PB-C-QUS220..... 105	
183614DE - 246014DE..... 99	2475-950952CL..... 6	CAN-34-60BH-230..... 107	DG92080CL..... 10	LID181 - LID301..... 54-55	PB-C-QUS220CL..... 105	
183614PC - 246014PC..... 99	2475-950CL..... 6	CAN-34-1436BC-PWB..... 107	DG93030..... 70	LTR-0813..... 41,46	PB-C-QUS230..... 105	
183614PE - 246014PE..... 99	2475-951..... 23	CAN-34-1448BC-PWB..... 107	DG93030CL..... 10	LTR-1300 - LTR-2400..... 13	PB-C-QUS230CL..... 105	
183634DE - 246034DE..... 99	2475-951CL..... 6	CAN-34-2036BC-PWB..... 107	DG93060..... 70	M18366DE - M24606DE..... 99	PB-DRTH..... 105	
183654DE - 246054DE..... 99	2475-952..... 23	CAN-34-2036BC-PWB..... 107	DG93060CL..... 10	M1836C46 - M2460C46..... 109	PB-HSC-LG - PB-HSC-XL..... 105	
1836BC6C - 2448BC6C..... 101	2475-952CL..... 6	CB14 - CB24..... 106	DG93060CO..... 57	M1836C47RE - M2460C47RE..... 110	PB-MC-TSH..... 105	
1836DS - 2460DS..... 98	2475-953..... 23	CC183663 - CC247274..... 114	DG93080..... 70	M1836C47RE - M2460C47RE..... 110	PB-MP-TWH..... 105	
1836F - 2460F..... 98	2475-953CL..... 6	CC183663CV - CC247274CV..... 114	DG93080CL..... 10	M1836CG46 - M2460CG46..... 109	PB-SCH-SC..... 105	
1836SG - 1860SG..... 88	2475-954..... 23	CD965 - CD1887..... 52	DG93080CO..... 57	M1836CG46RE - M2460CG46RE..... 109	PB-SPACER-KT..... 104	
1836SL - 2448SL..... 98	2475-954CL..... 6	CDUS233..... 13	DG93120..... 70	M1836CG46RE..... 111	PB-SRTH..... 105	
1836SL6C - 2448SL6C..... 97	3036C - 3072C..... 88	CL1239-000..... 50	DG93120CL..... 10	M2460CG46RE..... 111	PC3518-33 - PC3518-33-3..... 75	
1836SM - 2472SM..... 124	3036E - 3072E..... 88	CL1239-401..... 50	DG93120CO..... 57	M1836CG47RE..... 111	PC3518SHELF..... 75	
				M1836SG46 - M2460SG46..... 109	PC4026-33 - PC4026-33-3..... 75	
				M1836SG47 - M2460SG47..... 109	PC4026SHELF..... 75	
				M1836SL34C-M2448SL34C..... 97	PCL1 - PCL2..... 125	
				M1836SL6C - M2448SL6C..... 97	PCTH..... 75	
					PFTC4026-33-2 - PFTC4026-33-3..... 75	
					PH18 - PH24..... 123	

QUICK FIND MODEL NUMBER INDEX

M2036BD - M2048BD.....	100	PFTC4026-33-2.....	75	QFS270-72+QFS400.....	63	QLP-4861 - QLP-4861BG..	14	QPRS-109CL.....	8	QSB106CO.....	57
M2430CLAN.....	117	PFTC4026-33-3.....	75	QFS270-72.....	62	QLP-4861CO.....	56	QPRS-201.....	47	QSB107.....	41
M2436-69SEC - M2460-69SEC.....	113	PH18 - PH24.....	123	QFS400.....	65	QLR500.....	58,60	QPRS-202.....	47	QSB107BR.....	54
M2436C46E - M2460C46E.....	110	PT-NR.....	123	QGH600.....	30	QMD-36H.....	16	QPRS-207.....	47	QSB107CL.....	7
M2436C46RE - M2460C46RE.....	110	PT-NS.....	123	QGH600CL.....	9	QMD-36H-220.....	18	QPRS-209.....	47	QSB107CO.....	57
M2436C47RE - M2460C47RE.....	110	PT-PR.....	123	QGH700.....	30	QMD-36H-220CL.....	5	QPRS-501.....	51	QSB108.....	41
MD1836C46RE-MD2460C46RE.....	110	PT-PS.....	123	QGH700BR.....	54	QMD-36H-230.....	18	QPRS-5678.....	51	QSB108BR.....	54
MD1836C47RE-MD2460C47RE.....	110	PT-PSB.....	123	QGH700CL.....	9	QMD-36H-230240.....	18	QPRS-601.....	51	QSB108CL.....	7
MD1836CG46RE.....	106	PWB.....	106	QGH705MOB.....	30	QMD-36H-230240CL.....	5	QPRS-701.....	51	QSB108CO.....	57
.....MD2460CG46RE.....	111	QAT.....	111	QGH705MOBCL.....	9	QMD-36H-230CL.....	5	QPRS-801.....	51	QSB109.....	41
MD1836CG47RE.....	111	QB900.....	66	QGH800.....	30	QMD-36H-240.....	18	QRC-4D.....	39	QSB109BR.....	54
.....MD2460CG47RE.....	111	QBB-4845-34.....	74	QGH800CL.....	9	QMD-36H-240CL.....	5	QRC-7D.....	39	QSB109CL.....	7
MD2436-70SEC - MD2460-70SEC.....	113	QBC111.....	41,46	QGH805MOB.....	30	QMD-36HCO.....	56	QRB166.....	28	QSB109CO.....	57
MESH-240.....	37	QBC112.....	41,46	QGH805MOBCL.....	9	QMS531.....	33	QRB176MOB.....	28	QSB110.....	41
MESH-240250.....	37	QBR-1819.....	15	QIC-12123.....	64	QMS531BR.....	54	QRC206.....	28	QSB110BR.....	54
MESH-250.....	37	QBR-1819CO.....	56	QIC-122.....	64	QMS532.....	33	QRB216MOB.....	28	QSB110CL.....	7
MSB-C3036.....	76	QBR-2721.....	15	QIC-124-122.....	65	QMS532BR.....	54	QRB246.....	28	QSB110CO.....	57
MSB-C3036-230240.....	76	QBR-2721-210-24.....	18	QIC-124-161.....	65	QMS533.....	33	QRB256MOB.....	28	QSB111.....	41
MSU-16-MIX.....	34	QBR-2721-210-24CL.....	5	QIC-124-64.....	65	QMS533BR.....	54	QRU-1W.....	17	QSB114BR.....	54
MSU-531.....	34	QBR-2721-220-24.....	18	QIC-124-83.....	65	QMS543.....	33	QRU-12D.....	17	QSB114CL.....	7
MSU-532.....	34	QBR-2721-220-24CL.....	5	QIC-148-122.....	65	QMS543BR.....	54	QRU-12D-220-192.....	18	QSB114CO.....	57
MSU-533.....	34	QBR-2721-230-12.....	18	QIC-148-161.....	65	QMS743.....	33	QRU-12D-220-192CL.....	5	QSB116.....	41
MSU-543.....	34	QBR-2721-230-12CL.....	5	QIC-148-64.....	65	QMS743BR.....	54	QRU-12D-240-48.....	18	QSB116BR.....	54
MTT-1842-543.....	76	QBR-2721CO.....	56	QIC-148-83.....	65	QMS843MOB.....	33	QRU-12D-240-48CL.....	5	QSB116CL.....	7
MTT-1860-543.....	76	QBR-3612.....	15	QIC-161.....	64	QNS348.....	19	QRU-12DCO.....	55	QSB116CO.....	57
MTT-1878-543.....	76	QBR-3612CO.....	56	QIC-170-122.....	65	QNS358.....	19	QRU-12S.....	17	QSB201 - QSB216.....	46
MTT-3048-743.....	76	QBR-3619.....	15	QIC-170-161.....	65	QP965 - QP1887.....	52	QRU-12S-220-96.....	18	QSBU-230240.....	20
MTT-3060-743.....	76	QBR-3619-210-32.....	18	QIC-170-64.....	65	QPR-101.....	37	QRU-12S-220-96CL.....	5	QSBU-230240CL.....	5
MTT-3078-743.....	76	QBR-3619-210-32CL.....	5	QIC-170-83.....	65	QPR-102.....	37	QRU-12S-240-24.....	18	QSBU-239.....	20
MWR4-2419-9.....	72	QBR-3619-220-32.....	18	QIC-224-122.....	65	QPR-107.....	37	QRU-12S-240-24CL.....	5	QSBU-239CL.....	5
MWRS-1711-12.....	72	QBR-3619-220-32CL.....	5	QIC-224-161.....	65	QPRD-000.....	43,47	QRU-12SCO.....	55	QSBU-240.....	20
MWRS-1711-8.....	72	QBR-3619-230-18.....	18	QIC-224-64.....	65	QPRD-100.....	43	QRU-16D.....	17	QSBU-240CL.....	5
MWRS-5-92035.....	97	QBR-3619-230-18CL.....	5	QIC-224-83.....	65	QPRD-100CL.....	8	QRU-16D-230-96.....	18	QSBU-245CL.....	5
MWRS-5-92060.....	97	QBR-3619CO.....	56	QIC-248-122.....	65	QPRD-101.....	43	QRU-16D-230-96CL.....	5	QSBU-250.....	20
MWRS-5-92080.....	97	QCS10.....	53	QIC-248-161.....	65	QPRD-101CL.....	43	QRU-16DCO.....	55	QSBU-250CL.....	5
MWRS-7-103.....	97	QCS10CO.....	55	QIC-248-64.....	65	QPRD-102.....	8	QRU-16S.....	17	QSBU-255.....	20
MWRS-7-104.....	97	QCS-156.....	53	QIC-248-83.....	65	QPRD-102CL.....	8	QRU-16S-220230240.....	18	QSBU-255CL.....	5
MWRS-7-108.....	97	QCS20.....	53	QIC-270-122.....	65	QPRD-107.....	43	QRU-16S-220230240CL.....	5	QSBU-260.....	20
MWRS-7-110.....	97	QCS20CO.....	55	QIC-270-161.....	65	QPRD-107CL.....	8	QRU-16S-230-48.....	18	QSBU-260CL.....	5
MWRS-7-602.....	97	QCS220.....	53	QIC-270-64.....	65	QPRD-109.....	43	QRU-16S-230-48CL.....	5	QSBU-265.....	20
MWRS-7-604.....	97	QCS30.....	53	QIC-270-83.....	65	QPRD-109CL.....	8	QRU-16SCO.....	55	QSBU-265CL.....	5
MWRS-7-606.....	97	QCS30CO.....	55	QIC-4163.....	64	QPRD-201.....	47	QRU-MOB.....	5,17,18	QSBU-270.....	20
OP-39 - OP-147.....	80	QCS320.....	53	QIC-4244.....	64	QPRD-202.....	47	QRU-MOBICO.....	55	QSBU-270CL.....	5
OP-CC.....	84	QCS35.....	53	QIC-64.....	64	QPRD-207.....	47	QS-000.....	61	QSBU-600.....	31
ORG80032 - ORG803222.....	66	QCS35CO.....	55	QIC-8143.....	64	QPRD-209.....	47	QS-304-28.....	61	QSBU-600800.....	31
P6C - P96C.....	89	QCS40.....	53	QIC-8224.....	64	QPRD-501.....	51	QS-305306-56.....	61	QSBU-600800CL.....	9
P6E - P96E.....	89	QCS40CO.....	55	QIC-83.....	64	QPRD-5678.....	51	QS-305-36.....	61	QSBU-600CL.....	9
P6P - P96P.....	89	QDC2012-7.....	73	QLP-1819 - QLP-1819BG..	14	QPRD-601.....	51	QS-306-56.....	61	QSBU-700.....	31
P6S - P96S.....	89	QDC2115-9.....	73	QLP-1819-210-16.....	18	QPRD-701.....	51	QS-309-80.....	61	QSBU-700CL.....	9
PB-1X1-PH.....	105	QDC2115-12.....	73	QLP-1819-210-16CL.....	5	QPRD-801.....	51	QS-569-56.....	61	QSBU-800.....	31
PB-1X30-SR - PB-8X30-SR.....	105	QDC2115-17.....	73	QLP-1819-220-16.....	18	QPRHA-000.....	43,47	QS-725.....	61	QSBU-800CL.....	9
PB-24X48-2 - PB-24X48-4.....	104	QDC2213-12.....	73	QLP-1819-220-16CL.....	5	QPRHA-100.....	43	QS-BIG-101.....	61	QSC-36.....	36
PB-2-CH - PB-3-CH.....	105	QDC2420-12.....	73	QLP-1819-230-9.....	18	QPRHA-100CL.....	43	QSB100.....	41	QSC-36-4IS-12DS.....	36
PB-3-DMU.....	105	QDC2515-14.....	73	QLP-1819-230-9CL.....	5	QPRHA-101.....	8	QSB100BR.....	54	QSC-3672-4D.....	37
PB-3X80-DR - PB-8X80-DR.....	105	QDC2717-12.....	73	QLP-1819CO.....	56	QPRHA-101CL.....	8	QSB100CL.....	7	QSC-36-96-4IS.....	36
PB-5-DCEL - PB-8-DCEL.....	105	QDC2820-15.....	73	QLP-1861 - QLP-1861BG..	14	QPRHA-102.....	43	QSB100CO.....	57	QSC-36-FD.....	36
PB-6X12SHELF.....	105	QDL-2115.....	73	QLP-1861CO.....	56	QPRHA-102CL.....	8	QSB101.....	41	QSC-36-MIN.....	37
PB-BINCLIP.....	105	QDS300.....	60,63	QLP-2721.....	14	QPRHA-107.....	43	QSB101BR.....	54	QSC-361842.....	39
PB-C-QUS200.....	105	QDS-3666H.....	16	QLP-2721CO.....	56	QPRHA-107CL.....	8	QSB101CL.....	7	QSC-361872.....	39
PB-C-QUS200CL.....	105	QDS-3666HCO.....	56	QLP-3612.....	14	QPRHA-109.....	43	QSB101CO.....	57	QSC-361878.....	39
PB-C-QUS210.....	105	QDU-00.....	8,43,47,51	QLP-3612CO.....	56	QPRHA-109CL.....	8	QSB102.....	41	QSC-362472.....	39
PB-C-QUS210CL.....	105	QED401.....	49	QLP-3619 - QLP3619BG..	14	QPRHA-201.....	47	QSB102BR.....	54	QSC-362478.....	39
PB-C-QUS220.....	105	QED501.....	49	QLP-3619-210-32.....	18	QPRHA-202.....	47	QSB102CL.....	7	QSC-481878.....	39
PB-C-QUS220CL.....	105	QED601.....	49	QLP-3619-210-32CL.....	5	QPRHA-207.....	47	QSB102CO.....	57	QSC-482478.....	39
PB-C-QUS230.....	105	QED602.....	49	QLP-3619-220-32.....	18	QPRHA-209.....	47	QSB103.....	41	QSC-36S.....	36
PB-C-QUS230CL.....	105	QED603.....	49	QLP-3619-220-32CL.....	5	QPRHA-501.....	51	QSB103BR.....	54	QSC-3IS.....	39
PB-DRTH.....	105	QED604.....	49	QLP-3619-230-18.....	18	QPRHA-567.....	51	QSB103CL.....	7	QSC-48.....	38
PB-HSC-LG - PB-HSC-XL.....	105	QED606.....	49	QLP-3619-230-18CL.....	5	QPRHA-601.....	51	QSB103CO.....	57	QSC-4803.....	38
PB-MC-TSH.....	105	QED701.....	49	QLP-3619CO.....	56	QPRHA-701.....	51	QSB104.....	41	QSC-4804.....	38
PB-MP-TWH.....	105	QED801.....	49	QLP-3661 - QLP-3661BG..	14	QPRS-000.....	43,47	QSB104BR.....	54	QSC-4805.....	38
PB-SCH-SC.....	105	QESTP.....	126	QLP-3661-220-120.....	18	QPRS-100.....	43	QSB104CL.....	7	QSC-48S.....	38
PB-SPACER-KT.....	104	QFS124 - QFS270.....	63	QLP-3661-230-60.....	18	QPRS-100CL.....	8	QSB104CO.....	57	QSC-4IS-14DS.....	38
PB-SRTH.....	105	QFS124-31.....	62	QLP-3661-240-28.....	18	QPRS-101.....	43	QSB105.....	41	QSC-60 - QSC-60S.....	40
PC3518-33 - PC3518-33-3.....	75	QFS148-38.....	62	QLP-3661CO.....	56	QPRS-101CL.....	8	QSB105BR.....	54	QSC-60-BENCH.....	40
PC3518SHELF.....	75	QFS170-36.....	62	QLP-4819.....	14	QPRS-102.....	43	QSB105CL.....	7	QSC-64-2S-6DS.....	36
PC4026-33 - PC4026-33-3.....	75	QFS224-24+QFS400.....	63	QLP-4861-220-165.....	18	QPRS-102CL.....	8	QSB105CO.....	57	QSC-72 - QSC-72S.....	40
PC4026SHELF.....	75	QFS224-24.....	62	QLP-4861-230-80.....	18	QPRS-107.....	43	QSB106.....	41	QSC-C240.....	37
PCL1 - PCL2.....	125	QFS248-76+QFS400.....	63	QLP-4861-240-35.....	18	QPRS-107CL.....	8	QSB106BR.....	54	QSC-C240250.....	37
PCTH.....	75	QFS248-76.....	62	QLP-4819CO.....	56	QPRS-109.....	43	QSB106CL.....	7	QSC-C250.....	37

QUICK FIND MODEL NUMBER INDEX

QSC-QIC122..... 37	QUS245..... 13	snt180..... 68-69	WR5-543..... 35	WR8-240CL..... 4	WRC9-63-2448-105..... 118
QSC-QIC161..... 37	QUS245BR..... 54	snt185..... 68-69	WR5-600 - WR5-800..... 32	WR8-245CL..... 4	WRC-BC2448..... 118
QSC-QIC64..... 37	QUS245CL..... 4	snt190..... 68-69	WR5-600CL - WR5-800CL..... 9	WR8-250..... 21	WRCGR-63-2436..... 120
QSC-QIC83..... 37	QUS250..... 13	snt195..... 68-69	WR5-955..... 24	WR8-250CL..... 4WRCGR-63-2460 120
QSMC..... 96	QUS250BR..... 54	snt200..... 68-69	WR5-955CL..... 6	WR8-255..... 21	WRC-IT-1824..... 115
QSRT..... 111	QUS250CL..... 4	snt225..... 68-69	WR5-975..... 26	WR8-255CL..... 4	WRCPL-63-2460..... 120
QSS-1866H..... 16	QUS250CO..... 55	snt230..... 68-69	WR5-993..... 27	WR8-348 - WR8-348CL..... 19	WRCPL-63-2460-955..... 121
QSS-1866HCO..... 56	QUS255..... 13	snt240..... 68-69	WR5-995..... 27	WR8-348358 - WR8-348358CL..... 19	WRCS4-63-2436EP..... 112
QSS-3666H..... 16	QUS255BR..... 54	snt300..... 68-69	WR5-997..... 27	WR8-358 - WR8-358CL..... 19WRCS4-63-2460EP 112
QSS-3666HCO..... 56	QUS255CL..... 4	SP-1239 - SP-3099..... 82	WR6-13-MIX..... 82	WR8-950..... 24	WRCS4-74-2436EP..... 112
QTB301..... 58	QUS255CO..... 55	SSB-S3036..... 76	WR6-36-1236-101..... 44	WR8-950952..... 24WRCS4-74-2460EP 112
QTB302..... 58	QUS260..... 13	SSB-S3036-230240..... 76	WR6-36-1236-101CL..... 7	WR8-952..... 24	WRCSL5-63-1836..... 119
QTB303..... 58	QUS260BR..... 54	SSC2716-32-3L..... 122	WR6-36-1236-102..... 44	WR8-970..... 26WRCSL5-63-2448 119
QTB304..... 58	QUS260CL..... 4	SSC2716-32-3M..... 122	WR6-36-1236-102CL..... 7	WR9-201..... 48	WRCSL5-63-1836-104..... 119
QTB305..... 58	QUS260CO..... 55	SSC3018-33-3L..... 122	WR6-36-1236-107..... 44	WR9-202..... 48WRCSL5-63-2448-106 119
QTB306..... 58	QUS265..... 13	SSC3119-32-3M..... 122	WR6-36-1236-107CL..... 7	WR9-203..... 48	WRCSL5-63-1836EP..... 119
QTB309..... 58	QUS265BR..... 54	SSC3922-37-3M..... 122	WR6-36-1236-109..... 44	WR9-204..... 48WRCSL5-63-2448EP 119
QTB405..... 59	QUS265CL..... 4	SST-2436U - SST-2472U..... 122	WR6-36-1236-109CL..... 7	WR9-205..... 48	WRCSL5-63-1836EP-104..... 119
QTB406..... 59	QUS270..... 13	SST-MOB..... 122	WR63-1236C - WR63-3672C..... 91	WR9-206..... 48WRCSL5-63-2448EP-106 119
QTB409..... 59	QUS270BR..... 54	TBC-32WT..... 59	WR63-1436P - WR63-2472P..... 94	WR9-207..... 48	WRCSL5-74-1836-104220..... 119
QTB410..... 59	QUS270CL..... 4	TC-19 - TC-39..... 116	WR63-1836S - WR63-2472S..... 95	WR9-208..... 48WRCSL5-74-1848-104220 119
QTB411..... 59	QUS270CO..... 55	TC-500..... 66	WR63-1836SG - WR63-2460SG..... 96	WR9-209..... 48	WRDBS4-63-2436EP..... 112
QTB412..... 59	QUS275MOB..... 13	TR1-2516-8..... 71	WR6-24185..... 72	WR9-210..... 48WRDBS4-63-2460EP 112
QTB-LP-BKT..... 58,102	QUS275MOBBR..... 54	TR2-2516-8..... 71	WR6-260..... 21	WR9-214..... 48	WRDBS4-74-2436EP..... 112
QTF24..... 60	QUS275MOBCL..... 4	TR3-2516-8..... 71	WR6-260CL..... 4	WR9-216..... 48WRDBS4-74-2460EP 112
QTF320..... 60	QUS950..... 22	TR4-2516-8..... 71	WR6-265..... 21	WR9-36180..... 72	WRGR-63-2436..... 120
QTF320-42..... 60	QUS950CL..... 6	TR5-2516-8..... 71	WR6-265CL..... 4	WR9-531..... 35WRGR-63-2460 120
QTF48..... 60	QUS951..... 22	TR6-2516-8..... 71	WR6-953..... 24	WR9-92060..... 72	WR-PS..... 123
QTF70..... 60	QUS951CL..... 6	TR-96..... 66	WR6-953CL..... 6	WR9-92060CL..... 10	WR-RG..... 123
QTR24..... 60	QUS952..... 22	TS18C - TS24C..... 116	WR6-953954CL..... 6	WR9-93060..... 72	WR-S24W..... 10,117
QTR48..... 60	QUS952CL..... 6	TS32C - TS62C..... 116	WR6-954..... 24	WR9-93060CL..... 10	WRS4-63-1836SS..... 96
QTR70..... 60	QUS953..... 22	TT-CT9 - TT-CT15..... 77	WR6-954CL..... 6	WRA86-2136C-166..... 29WRS4-86-2460SS 96
QUS200..... 13	QUS953CL..... 6	TTD-30 - TTD-40..... 77	WR6-973..... 26	WRA86-2142C-206..... 29	WRS-5-92035..... 97
QUS200BR..... 54	QUS954..... 22	TT-OT9 - TT-OT15..... 77	WR6-973974..... 26	WRA86-2148C-246..... 29	WRS-5-92060..... 97
QUS200CL..... 4	QUS954CL..... 6	TTS-18 - TTS-24..... 77	WR6-974..... 26	WRA86-2154C-166..... 29	WRS-5-92080..... 97
QUS205CO..... 55	QUS955..... 22	TUB1711-8..... 71	WR7-20-MIX..... 24	WRA86-2172C-246..... 29	WRS-7-103..... 97
QUS210..... 13	QUS955CL..... 6	TUB1711-12..... 71	WR7-245CL..... 4	WR-CH..... 118	WRS-7-104..... 97
QUS210BR..... 54	QUS956AMOB..... 22	TUB2417-8..... 71	WR74-1236C - WR74-3672C..... 92	WRC-1836-2..... 115	WRS-7-108..... 97
QUS210CL..... 4	QUS956AMOBCL..... 6	TUB2417-12..... 71	WR74-1436P - WR74-2472P..... 94	WRC-1836-2CG..... 115	WRS-7-110..... 97
QUS210CO..... 55	QUS956MOB..... 22	TUB2419-9..... 71	WR74-1436S - WR74-2472S..... 95	WRC-1836-2G..... 115	WRS-7-602..... 97
QUS220..... 13	QUS956MOBCL..... 6	TUB2516-8..... 71	WR74-1248-101102..... 45	WRC-1836-3..... 115	WRS-7-604..... 97
QUS220BR..... 54	QUS970..... 25	UB10..... 125	WR74-1248-110101..... 45	WRC-1836-3CG..... 115	WRS-7-606..... 97
QUS220CL..... 4	QUS973..... 25	UH18 - UH24..... 123	WR74-1248-66102..... 45	WRC-1836-3G..... 115	WRSAD4-63-1836SS..... 96
QUS220CO..... 55	QUS974..... 25	W7-12-24..... 52	WR74-1260-101102..... 45	WRC-1842-2..... 115WRSAD4-86-2460SS 96
QUS221..... 13	QUS975..... 25	W7-12-26..... 52	WR74-1260-143101..... 45	WRC-1842-3..... 115	WRSC3-42-2436FS..... 122
QUS221BR..... 54	QUS976..... 25	W7-12-28..... 52	WR74-1260-88102..... 45	WRC-1848-2..... 115WRSC3-42-2460FS 122
QUS221CL..... 4	QUS984AMOB..... 25	W7-12-30..... 52	WR74-1272-101102..... 45	WRC-1848-2CG..... 115	WR-SP..... 125
QUS224..... 13	QUS985MOB..... 25	W7-14-18..... 52	WR74-1272-110102..... 45	WRC-1848-2G..... 115	WR-SS..... 125
QUS224BR..... 54	QUS986MOB..... 25	W7-18-24..... 52	WR74-1272-176101..... 45	WRC-1848-3..... 115	WR-WMB..... 125
QUS224CL..... 4	QUS993..... 25	W7-18-26..... 52	WR74-1836SG - WR74-2460SG..... 96	WRC-1848-3CG..... 115	WS-1218DS - WS-1836DS..... 103
QUS230..... 13	QUS994AMOB..... 25	W7-18-28..... 52	WR74-1848-103104..... 45	WRC-1848-3G..... 115	WS-HB18 - WS-HB36..... 103
QUS230BR..... 54	QUS995..... 25	W7-18-30..... 52	WR74-1848-110103..... 45	WRC2-1836-1265..... 52	WS-DS18 - WS-DS48..... 102
QUS230CL..... 4	QUS996MOB..... 25	WGH600 - WGH800..... 30	WR74-1848-66104..... 45	WRC2-1836-1285..... 52	WS-DS18AD - WS-DS48AD..... 102
QUS230CO..... 55	QUS997..... 25	WH-15..... 66	WR74-1860-103104..... 45	WRC2-1836-1867..... 52	WS-PM36 - WS-PM48..... 102
QUS233..... 13	QUS998MOB..... 25	WK..... 126	WR74-1860-143103..... 45	WRC2-1836-1887..... 52	WS-SS18 - WS-SS48..... 102
QUS233BR..... 54	QVTRK..... 126	WMS531 - WMS543..... 33	WR74-1860-88104..... 45	WRC2-36-3036-976..... 112	WS-SS18AD - WS-SS48AD..... 102
QUS233CL..... 4	QVTRK-2-72EST..... 89	W-PC-STUD..... 89	WR74-1872-103104..... 45	WRC-2436-2..... 115	WS-SS18-6BC1..... 103
QUS233CO..... 55QVTRK-2-240EST 127	W-PLB..... 89	WR74-1872-110104..... 45	WRC-2436-2CG..... 115WS-SS18-6BC3 103
QUS234..... 13	QVTRK-3-72EST..... 89	W-PLI..... 89	WR74-1872-176103..... 45	WRC-2436-2G..... 115	WS-SS18-Q6BC1..... 103
QUS234BR..... 54QVTRK-3-240EST 127	WR-00..... 123	WR74-2448-105106..... 45	WRC-2436-3..... 115WS-SS18-Q6BC3 103
QUS234CL..... 4	RC1215-089..... 67	WR-00CO..... 123	WR74-2448-110105..... 45	WRC-2436-3CG..... 115	WS-SS36-6BC1..... 103
QUS235..... 13	RC2415-075..... 67	WR-00H..... 123	WR74-2448-66106..... 45	WRC-2436-3G..... 115WS-SS18-12BC3 103
QUS235BR..... 54	RC2415-089..... 67	WR-00HS..... 123	WR74-2460-105106..... 45	WRC-2442-2..... 115	WS-SS36-Q6BC1..... 103
QUS235CL..... 4	RC2415-111..... 67	WR10-230240..... 21	WR74-2460-143105..... 45	WRC-2442-3..... 115WS-SS18-Q12BC3 103
QUS235CO..... 55	RC2415-147..... 67	WR10-230240CL..... 4	WR74-2460-88106..... 45	WRC-2448-2..... 115	WUS221 - WUS270..... 13
QUS239..... 13	RSO1207-5..... 67	WR12-101 - WR12-116..... 44	WR74-2472-105106..... 45	WRC-2448-2CG..... 115	WUS950 - WUS955..... 22
QUS239BR..... 54	RSO1215-5..... 67	WR12-101CL - WR12-116CL..... 7	WR74-2472-110106..... 45	WRC-2448-2G..... 115	WUS970 - WUS976..... 25
QUS239CL..... 4	RSO1215-7..... 67	WR12-93030..... 72	WR74-2472-176105..... 45	WRC-2448-3..... 115	
QUS239CO..... 55	RSO1408-7..... 67	WR12-93030CL..... 10	WR7-532..... 35	WRC-2448-3CG..... 115	
QUS240..... 13	RSO2415-5..... 67	WR-3..... 123	WR7-92080..... 72	WRC-2448-3G..... 115	
QUS240BR..... 54	RSO2415-7..... 67	WR4-12225..... 72	WR7-92080CL..... 10	WRC2-63-3036-974976..... 112	
QUS240CL..... 4	RSO2415-9..... 67	WR5-270..... 21	WR7-951..... 24	WRC3-1836-1265..... 52	
QUS240CO..... 55	RSO2422-11..... 67	WR5-270CL..... 4	WR86-1236C - WR86-3672C..... 93	WRC3-1836-1285..... 52	
QUS241..... 13	SCH1 - SCH1-5..... 101,125	WR54-1236C - WR54-3672C..... 90	WR86-1436P - WR86-2472P..... 94	WRC3-1836-1867..... 52	
QUS241BR..... 54	SD36C - SD60C..... 113	WR54-1436P - WR54-2472P..... 94	WR86-1436S - WR86-2472S..... 95	WRC3-1836-1887..... 52	
QUS241CL..... 4	SDIV-12-6 - SDIV-30-6..... 85	WR54-1836S - WR54-2472S..... 95	WR86-1836SG - WR86-2460SG..... 96	WRC5-63-2436-93060..... 117	
QUS242..... 13	S-HOOK..... 125	WR5-36MSBA..... 100	WR8-239..... 21WRC5-63-2460-93060 117	
QUS242BR..... 54	SL12 - SL30..... 124	WR5-36MSBA-MOB..... 100	WR8-239CL..... 4	WRC5-63-2436-93060CL..... 10	
QUS242CL..... 4	snh010..... 68,71	WR5-533..... 35	WR8-240..... 21WRC5-63-2460-93060CL 10	